

Radio Circuits

A Step by Step Survey

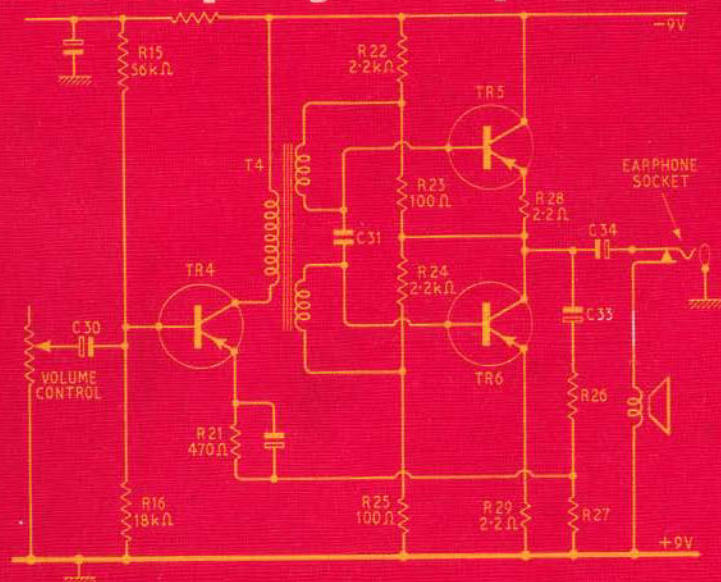

W. E. MILLER, M.A. (Cantab.), M.I.E.R.E.

Revised by

E. A. W. SPREADBURY, C.Eng., M.I.E.R.E.

Over 85,000 copies sold

RADIO CIRCUITS

A STEP-BY-STEP SURVEY

W. E. MILLER, M.A.(Cantab), M.I.E.R.E.

Revised by

E. A. W. SPREADBURY, C.Eng., M.I.E.R.E.

Technical Editor *Electrical and Electronic Trader*

LONDON ILIFFE BOOKS LTD.

First Published 1941
Second Edition 1942
Third Edition 1951
Fourth Edition 1959
Fifth Edition © Iiffe Books, Ltd., 1966

*Published for ELECTRICAL AND ELECTRONIC TRADER by Iiffe Books, Ltd., Dorset House,
Stamford Street, London S.E.1*

Printed and bound in England by The Chapel River Press, Andover, Hants.

CONTENTS

<i>preface</i>	7
abbreviations	9
1 superhet principles	1
2 aerial input circuits	6
3 tuned input stage	12
4 band-pass coupling	16
5 r.f. amplifier stage	20
6 frequency-changing	24
7 oscillator arrangements	27
8 early f.c. circuits	31
9 later f.c. valves	37
10 oscillator tracking	39
11 i.f. amplifiers	43
12 variable selectivity	49
13 demodulation circuits	52
14 a.g.c. principles	57
15 delayed a.g.c.	60
16 a.g.c. circuit variations and a note on a.f.c.	64
17 a.f. amplification	69
18 practical a.f. circuits	73
19 second a.f. stages	77
20 push-pull circuits	81
21 push-pull r.c. stages	83
22 q.p.p. a.f. output	86
23 class B a.f. output	89
24 loudspeaker arrangements	91
25 a.c. power supplies	97
26 a.c./d.c. power supplies	103
27 mains/battery portables	111
28 tone control circuits	117

CONTENTS

29	negative feedback	121
30	gramophone reproduction	124
31	special tuning devices	127
32	f.m. receivers	137
33	f.m. i.f. stages	146
34	f.m. detector stage	150
35	combined a.m./f.m. receivers	154
36	transistor circuits	161
37	transistored receivers	165
38	transistored tuning circuits	170
39	transistor audio stages	176
40	transistored a.m./f.m. receivers	185
41	hybrid circuits	194
42	car radio	197
	appendix	207
	<i>index</i>	223

PREFACE

It is more than a quarter of a century since the first edition of this book was written by W. E. Miller, M.A.(Cantab.) and in the course of the four editions that have preceded this one, well over 85,000 copies have been sold. The present author took over the revision at the third edition, which was published in 1951, and although in the fourth edition, eight years later, it was again brought right up to date, subsequent technical development has been so rapid that the fourth edition is already very much outdated.

Radio theory has not changed, but the new techniques, and in particular the development of transistors, have completely revolutionized radio receiver design, particularly in the field of portables and car receivers where valves have become almost completely outmoded.

To dive straight into a description of some of the highly sophisticated modern circuits, however, would leave many readers, who already have a nodding acquaintance with valved receivers, rather bewildered, and to avoid this a full description of all the valved circuits on which radio receiver techniques are founded has been retained. In addition to helping the novice to work up gradually to modern circuitry, this policy will be welcomed by the keen amateur or hobbyist, who has access to old valve receivers with which he can experiment, because the early chapters of this book will explain to him the kinds of circuits they employ.

With a few modifications therefore, Chapters 1-31, which cover the whole structure on which a.m. radio receiver design has been developed, are retained very much in the form in which they appeared in the fourth edition, and these explain the development of valve circuits over the years. They are followed by revised chapters on valved f.m. and a.m./f.m. circuits, and then from Chapter 36 onwards there are seven entirely new chapters on transistored circuits and car radio.

As all the new circuitry is still founded on the same principles as the valve circuitry that preceded it, and valves are easier to understand than transistors, the reader is taken by the easiest possible route to an introduction to the transistor, with all the knowledge behind him that led up to the modern type of circuit, like the "old hand" who has been in the industry since it started.

Thus any reader who understands what a resistor, a capacitor, a coil and a valve are can learn from this book how these components are combined to make radio receivers, old and new, perform their function. Such readers will not look for scientific discourse on radio theory, and that is not the function of this book, but they will find that a practical explanation of the theory of the operation of an f.m. discriminator is





PREFACE

given (in the Appendix) because that is one part of radio theory that appears not to be widely understood. Even here, however, mathematics are avoided entirely, as in the rest of this book. This factor, coupled with the shortness of most of the early chapters, should make the book easy to read and absorb.

Dorset House,
London S.E.1

E. A. W. SPREADBURY

ABBREVIATIONS USED IN THIS BOOK

a.c.	alternating current		
a.c./a.d.	applicable to a.c. mains or batteries		
a.c./d.c.	applicable to a.c. or d.c. mains		
a.c./d.c./a.d.	applicable to a.c. or d.c. mains or batteries		
a.d.	all-dry batteries		
a.f.	audio frequency		
a.g.c.	automatic gain control		
a.m.	amplitude modulation		
c.r.	cathode ray		
c/s	cycles per second		
d.c.	direct current		
d.h.	directly heated		
f.m.	frequency modulation		
g.b.	grid bias		
h.t.	high tension		
i.f.	intermediate frequency		
i.h.	indirectly heated		
kc/s	kilocycles per second		
l.t.	low tension		
l.w.	long waveband		
mA	milliampere		
Mc/s	megacycles per second		
m.w.	medium waveband		
pF	picofarad (formerly $\mu\mu\text{F}$, or micromicrofarad)		
p.m.	permanent magnet (speaker)		
q.m.b.	quick make-and-break		
q.p.p.	quiescent push-pull		
r.c.e.	ray control electrode		
superhet	supersonic heterodyne receiver		
s.w.	short waveband		
t.r.f.	tuned radio frequency		
v.h.f.	very high frequency (Band II)		
μF	microfarad		
	fixed capacitor		
	variable capacitor		true earth
	pre-set capacitor		chassis

CHAPTER 1

SUPERHET PRINCIPLES

Radio receiver circuits can be divided broadly into two classes, those which employ what is known as a "straight" or tuned radio frequency circuit (usually abbreviated to t.r.f.), and those which utilize the superheterodyne type of circuit (usually abbreviated to superhet).

In the course of time the superheterodyne receiver has become increasingly popular, so much so, that the use of the t.r.f. circuit in ordinary domestic radio receivers is now quite uncommon, except in the simplest and lowest priced types of set. In this book, therefore, the superhet will be dealt with exclusively, but it should be pointed out that anyone with a good knowledge of superhet circuits will have no difficulty in understanding the simpler "straight" type of receiver. Many sections of the book, though written with the superhet type of circuit in mind, are equally applicable to the "straight" receiver. For instance, aerial circuits, r.f. couplings, a.f. and output circuits and power supply arrangements are virtually the same in both types of receiver.

We have just seen that fundamentally radio receivers can be divided into two classes: t.r.f. and superhet, and we have also decided to confine our main activities to the superhet. Since the third edition of this book was written, however, there has been introduced into broadcasting, and therefore into domestic radio receivers, another division in broadcasting technique just as fundamentally different from the old order as is the superhet from the t.r.f. receiver.

This is broadcasting on very high frequencies (abbreviated to v.h.f.), and as a result of this radio receivers, or rather the systems used for radio transmission and reception, can be divided into two further classes: "ordinary" or conventional receivers that operate on the medium waveband (m.w.), long waveband (l.w.) and short waveband (s.w.), using amplitude modulation (a.m.); and a different class of receiver which made its appearance in 1955 and operates in

the v.h.f. region (in Band II) and uses frequency modulation (f.m.).

Both types of receiver will be dealt with in this book, but the treatment of the two classes is quite different, and the a.m. receiver will be discussed first, on the assumption that it is more familiar to the reader, without reference to the f.m. receiver. The f.m. receiver will then be treated separately, with occasional reference to the a.m. receiver. After that it will be possible to combine the two, and that is the form in which the modern domestic radio receiver is usually found.

The principles of the superheterodyne, though more difficult to understand than those of the t.r.f. receiver, are easy to grasp once the circuit is split up into its various sections, when each section can be studied separately.

The reason for the popularity of the superhet is that it enables stable and controllable amplification to be carried out with very little difficulty, and it does this by converting the incoming signal from the high frequency at which it is transmitted to a lower frequency (known as the intermediate frequency, or i.f.). To secure a high degree of amplification of a radio frequency signal without encountering instability is a difficult matter; at the lower frequency to which the signal is converted amplification is relatively simple.

There is another reason for the use of the superhet, however. In order to secure adequate selectivity in a receiver, we must have a number of tuned circuits. In a "straight" receiver, where all the amplification (except in the audio frequency or a.f. stages) is carried out at the signal frequency, each stage must obviously be tunable over the whole frequency range covered by the set. Thus in order to permit tuning with a single control, a ganged tuning capacitor with as many sections as there are tuned circuits would be necessary, and each stage would also have to have its own complete set of coils, with their associated wavechange switches. In mass production, the difficulties of ganging and stabilizing all the tuned circuits would be considerable.

In the superhet, the incoming signal, *whatever its frequency*, is converted to the *fixed* intermediate frequency, at which the major part of the amplification is carried out, in what is termed the intermediate frequency amplifier (usually abbreviated to i.f. amplifier). The advantages of this are easy to see. In the first place, the tuning of the intermediate frequency amplifying stages is fixed. It is accurately adjusted at the factory, and need only be touched when complete re-alignment of the set becomes necessary. The variable tuning of the set is carried out in the stages prior to the i.f. amplifier, and in the last of these early stages the signal frequency

is converted to the intermediate frequency. This last stage is known as the frequency-changing stage.

Most receivers have no amplification prior to the frequency-changing stage, so that the variable tuning at the signal frequency is simplified down to one aerial tuning circuit, but in a superhet circuit there must always be a tuning circuit in the frequency-changer section, the latter being the oscillator tuning (which will be dealt with later). In this simple superhet circuit, therefore, a two-gang variable capacitor is all that is needed, the required degree of selectivity, of which we will learn more later, being obtained from the fixed-tuned i.f. stages. From the foregoing, therefore, it follows that in the normal domestic receiver there is a variable-tuned aerial circuit, a variable-tuned oscillator circuit, and an unspecified number of fixed-tuned circuits in the i.f. amplifier.

The usual i.f. stage consists of a single amplifier valve, a transformer generally being used to couple the frequency-changer to the grid circuit of the i.f. valve, and another similar transformer coupling the anode circuit of the i.f. valve to the following stage, which is the detector, or demodulator. The two transformers, each with a tuned primary and a tuned secondary winding, provide four tuned circuits which, with the single-tuned aerial circuit (neglecting the oscillator tuning), gives five tuned circuits in all. These can be made to give adequate selectivity for all normal requirements.

Where additional selectivity is needed, the manufacturer generally provides a stage of signal frequency amplification, usually known as radio frequency amplification and abbreviated to r.f., between the aerial and the frequency-changer stage, which is known as the pre-amplifier or pre-selector stage. This stage, by virtue of a tuned coupling between it and the frequency-changer, gives an extra tuned circuit, besides handing on an amplified signal. Its use today, however, in domestic a.m. receivers is so rare as to be exceptional.

If this additional valve is not used, two tuned circuits between the aerial and the frequency-changer, arranged to give band-pass characteristics, are sometimes used. In both these cases a three-gang tuning capacitor (two for signal and one for oscillator tuning) will be employed. A third method that is sometimes used is to add a second i.f. amplifying stage, incorporating one or two additional fixed-tuned circuits which increase the selectivity of the receiver without adding a third section to the ganged variable tuning capacitor.

Fig. 1 is a block diagram showing the stages of a simple superhet receiver, in which the pre-selector stage is dotted to indicate that it is not always used. The frequency-changer is split into two units,

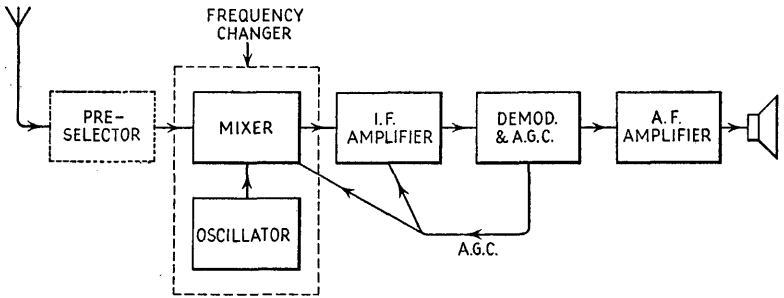

Fig. 1. Block diagram of a simple superhet circuit, showing the separate stages which are described in the text. The two sections of the frequency-changer may be embodied in a single valve

the mixer and the oscillator. In order to produce the required intermediate frequency, the incoming signal and a locally generated oscillation are caused to heterodyne each other: that is to say, they are mixed together, and produce new frequencies, one equal to the sum of the oscillator and signal frequencies and the other equal to the difference between them. It is usually the latter which is selected for amplification in the i.f. stages, the sum frequency and the original signal and oscillator frequencies being filtered out.

Although the two sections of the frequency-changer are shown separately in the block diagram, the receiver does not necessarily use two separate valves for them, although in some sets separate valves are in fact employed. More usually a single frequency-changer valve is used which combines the two functions.

It is clear that since the intermediate frequency signal obtained from the frequency-changer has to be fixed in frequency, and since the incoming signal may vary over a wide range of frequencies according to the station being received, the oscillator stage must be variably tuned so that its frequency always differs from that of the incoming signal by a constant amount, the difference naturally being the value of the intermediate frequency.

Consequently, with a single tuning control, and the signal and oscillator tuning ganged, special arrangements (known as tracking or padding) have to be made so that this constant frequency difference is accurately maintained over the whole signal frequency range covered by the set.

As has already been mentioned, the output from the frequency-changer is passed to the i.f. stage for amplification, but, as in the case of a modulated r.f. signal (with which it is identical, except for being of a lower frequency), it must be "detected" or demodulated

before it can be passed to the audio frequency stages for further amplification. The stage which performs the demodulation is often known as the second detector, the reason being that in early superhets the frequency-changer was known as the first detector. Although this term has been largely abandoned, the demodulator is still widely known as the second detector.

Whereas in a "straight" receiver the valve used for demodulation is usually a triode, tetrode or pentode, in the modern superhet it is almost invariably a diode, because in this type of set there is an adequate signal voltage to load a diode properly, which results in comparative freedom from distortion.

Often a double-diode is used, one of the two diodes being used for demodulation and the other, also fed from the i.f. stage, being used to provide a d.c. bias voltage for automatic volume (or gain) control purposes. This voltage varies in accordance with the strength of the incoming signal, and is fed back to the frequency-changer and i.f. stages as negative grid bias. With a weak incoming signal only a small bias is applied to these valves, which therefore operate at full amplification and tend to compensate for the weak signal. With a strong incoming signal a large negative bias is applied, with the result that the amplification of the early stages is reduced. Automatic gain control is usually abbreviated to a.g.c.

After leaving the demodulator stage the a.f. modulation of the signal is amplified by one or two a.f. stages. Sometimes the first stage a.f. valve forms part of the demodulator and a.g.c. valve, which may be, for instance, a double-diode-triode type of valve. Where a high gain output pentode is used, the output from the demodulator may be resistance-capacitance-coupled direct to the output valve, with no intermediate a.f. stage. A double-diode output pentode may then be employed.

This, then, is a very brief sketch of a simple modern superhet receiver, and it will now be necessary to examine the circuit stage by stage.

CHAPTER 2

AERIAL INPUT CIRCUITS

In considering the superheterodyne circuit in detail, it is proposed to follow the passage of the signal through the receiver from the point of entry, that is, from the aerial-earth circuit. This is the most convenient method to adopt from the point of view of understanding the circuit, but it should be explained that it is not the best way to work in tracing faults in the set. For the latter purpose it is usually best to work from the loudspeaker backwards to the aerial circuit.

The first circuit in the receiver is that to which the aerial and earth of the set are connected, and its purpose is to transfer the signal to the tuned circuit which follows it. The aerial circuit of a modern receiver is rarely, if ever, directly tuned unless it consists of a frame aerial or some other type of internal aerial in the receiver. Instead, the aerial is coupled to the first tuned circuit by some means or another.

In all open aerial types of receivers the signal is merely handed on from the aerial circuit to the first tuned circuit, and the method by which this is done varies quite considerably. Although the aerial circuit is not tuned, it is often arranged to resonate at some part of the band to which the receiver normally tunes, to increase the efficiency of transfer of the signal at this part of the tuning range. This is arranged by the designer of the set who may wish to increase the sensitivity over a certain frequency band, to compensate for a deficiency elsewhere in the circuit.

If all aerial and earth systems likely to be used with the set were identical in constants, that is, if they had the same capacitance, inductance and r.f. resistance, it would be easy to design a very efficient aerial circuit. Unfortunately, aerials vary from a few feet of wire trailing behind the set on to the floor, to a super outdoor type some forty feet high and a hundred feet long.

What the designer has to do is to arrange matters so that whatever aerial is used there will be no noticeable difference in effect on the

first tuned circuit of the receiver. It will be appreciated that this circuit, in a modern set, is ganged with the other tuned circuits, and its constants must not vary, whatever the conditions of use of the set.

Consequently, the coupling between the aerial circuit and the first tuned circuit must be small enough to prevent the aerial system from appreciably affecting the tuned circuit, while at the same time being adequate to pass on the signal voltage efficiently at all frequencies to which the set may be tuned. There are several methods of coupling that can be adopted in order to reduce the loading of the aerial system on the first tuned circuit, and their general principles are as follows, beginning with the simplest.

The first method is to use a small fixed capacitor in series with the aerial, which, in the usual manner of capacitors in series, lowers the apparent capacitance of the aerial, and reduces its effect on the first tuned circuit (Fig. 2(a)). At the same time, because of the impedance it inserts in the circuit, it also reduces the signal voltage handed on.

Furthermore, the lower the frequency of the signal the higher the impedance of the series capacitor, and the smaller the proportion of the signal which reaches the set. Another disadvantage of the series capacitor alone is that unless it is very low in capacitance (resulting in very small aerial coupling) the aerial will still have an appreciable effect on the first tuned circuit, damping it and rendering the receiver unselective.

The second method of aerial coupling is to use an inductance coil connected between aerial and earth and coupled to the coil of the first tuned circuit (Fig. 2(b)). The signal voltage in the aerial system is built up across the coupling coil, and induced into the tuned

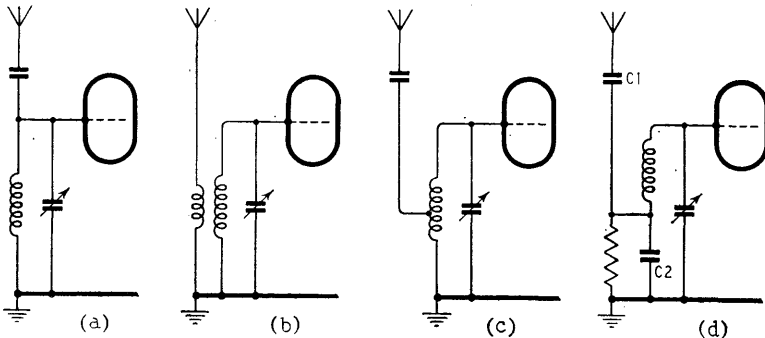

Fig. 2. Showing four basic types of aerial coupling circuit in simplified form
R.C.—2

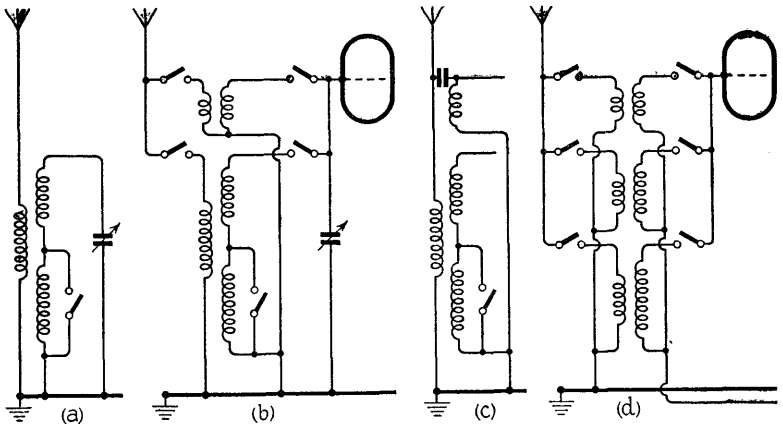

Fig. 3. Four examples of multi-band aerial coupling circuits. The bottom coils in each case are for the l.w. band, the next upwards for m.w., and the top ones for s.w., as is indicated respectively by the number of turns shown

circuit. The coupling depends on the number of turns of wire and on the proximity of the coupling coil to the tuned coil. If only a few turns of wire are used in the coupling coil, they will generally be wound over or close to the tuned coil. Sometimes, however, the designer uses a comparatively large number of turns in his coupling coil, but spaces it well away from the tuned coil.

A third method, which is not often used, is shown in Fig. 2(c). Here the aerial is tapped into the winding of the tuning coil, so that the coil acts as a kind of auto-transformer. This method is effectively equivalent to using a coupling coil of the type shown in Fig. 2(b). A fourth, and in latter years very common, type of aerial coupling is the "bottom capacitance" method shown in Fig. 2(d). The aerial is taken (usually via a series capacitor C1) to the junction of the coupling coil and the "bottom capacitor" C2. There is some similarity between this and Fig. 2(c), because C2 and the variable tuning capacitor are actually connected in series across the coil, and the aerial current, in flowing through C2 to chassis, flows through part of the capacitive section of the circuit in the same way as in Fig. 2(c) it flows through part of the inductive section.

Where coupling to several tuned circuits (for different wavebands) is necessary, the same method may be used in each band, or a mixture of the methods just described may be employed. When coupling coils are adopted, a single coupling coil may be used for more than one band, and it is then designed to give the best possible compromise on each band. While a single coupling coil is often

used in a two-band (medium and long wave) receiver (Fig. 3(a)), it is generally found that in a three-band (short, medium and long wave) set a separate coupling coil is used for the s.w. band, with suitable switching (Fig. 3(b)). Sometimes the aerial is inductively coupled on the m.w. and l.w. bands, and capacitatively coupled on the s.w. band (Fig. 3(c)). One quite common arrangement in a three-band set makes use of a separate coupling coil, with switching, for each waveband (Fig. 3(d)). This not only makes for the greatest efficiency on each band, but also permits the use of separate coil units for each band, the coils being wound in pairs on separate formers. The bands can then be made quite independent of one another.

Although aerial coupling coils are often shown in circuit diagrams as having fewer turns than the tuned coils to which they are coupled, it can be gathered from what has already been said that in practice they may consist of a greater number of turns than the tuned coil. In any case, the d.c. resistance of the coupling coil is generally higher than that of the tuned coil, and may be ten times as great. Occasionally the coupling coil will be wound of resistance wire to produce a flat resonance peak, and its resistance will naturally be quite high, though it may be small in physical dimensions.

Three different basic arrangements in which bottom capacitance coupling is used are shown in Fig. 4. At (a) is seen a coupling

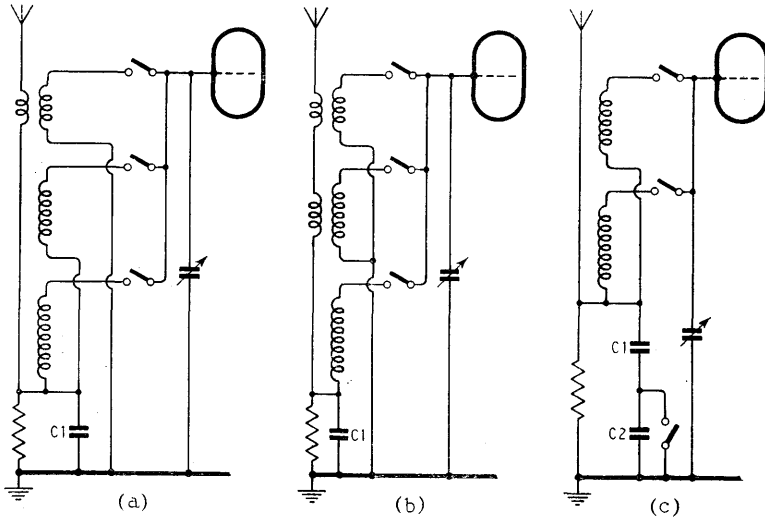

Fig. 4. Three representative forms of "bottom capacitance" aerial coupling in multi-band receivers

circuit in which m.w. and l.w. tuning coils are coupled to the aerial by the capacitor C1, while the s.w. coil is coupled inductively by a separate coil. At (b) both the s.w. and m.w. tuning coils are inductively coupled but the l.w. coil is bottom coupled by C1. The impedance of a capacitor varies with frequency, so that a capacitor that provides optimum coupling on one band will not do so on another, and this is taken care of in (c), where C1 and C2 in series provide the optimum coupling impedance on m.w., but on l.w. C2 is short-circuited by a switch, leaving on C1 in circuit and again providing an optimum coupling impedance.

The coupling arrangements described are the simplest ones, and though largely used, they by no means embrace all the possible arrangements. Some sets have extremely elaborate aerial circuits, with capacitative potential dividers, fixed capacitors associated with the coupling coils, and other arrangements introduced by the designer to keep the sensitivity as constant as possible on all wavebands. A coupling coil may be shunted by a fixed capacitor to tune it to a frequency outside the range covered by the tuning circuits, so as to prevent it from interfering with them by resonating within the band. Sometimes a resistance is used as a shunt across the aerial-earth circuit. This has a number of reasons, of which the most common one is to prevent charges from accumulating in the capacitors and to prevent modulation hum, which otherwise may occur in mains receivers. Modulation hum is heard only when the receiver is tuned to a station.

Again, a series-tuned circuit is sometimes found across the aerial-earth circuit. This is usually intended for use as an i.f. filter. It is tuned to the intermediate frequency of the set, and bypasses signals of that frequency, thus preventing interference from signals of that frequency that are picked up by the aerial. Otherwise they may be passed through the frequency-changer and amplified in the i.f. stages of the set. Sometimes a parallel-tuned circuit is inserted in series with the aerial connection to the circuit, and when this is tuned to the value of the i.f. it acts as a rejector, blocking the entry of signals of this frequency from the aerial into the set.

Occasionally other tuned filters or rejectors are to be found in the aerial circuit of a receiver, usually intended to reduce the effect of some powerful near-by station, particularly if it is received on the "second channel" frequency as an "image" signal. This results from a strong local signal forcing its way through the tuned input circuit to the frequency-changer and producing a "beat" with the oscillator which, as a result of mixing the two frequencies, causes a signal from a m.w. station to appear on the l.w. band.

The case of frame aerial receivers is rather different. Here the frame aerials themselves are used as the first tuned circuits. If provision is made for the use of an external aerial, coupling is generally arranged either by means of a small series capacitor, or by a turn or two of wire coupled to the frame winding.

At one time, frame aerials were used only in portable receivers, but it became a common practice to incorporate small frame aerial windings in table receivers, so that in locations within reasonable range of a transmitter no kind of external aerial was necessary. These aerials were wound flat, like a square pancake, but they were quite efficient, air-spaced, wire-wound frames.

Since the second world war, ferrous oxide materials known as ferrites have been widely used as cores in quite small coils, and their radio frequency behaviour is such that if the core they comprised was made several inches long, it would act as a very efficient portable aerial, quite small tuning coils wound on its ends picking up a signal on m.w. and l.w. as efficiently as much larger frame aerial windings. Such assemblies, comprising a ferrite rod with a small m.w. coil at one end and a l.w. coil at the other, are called ferrite rod aerials, and at the time of writing most portable and table receivers use them. In some receivers they are pivoted so that they can be aligned with the direction of the transmitter, irrespective of the position of the receiver itself.

Ferrite rod aerial assemblies are usually indicated in a circuit diagram in the manner demonstrated in Fig. 5. At (a) the assembly is shown entirely as an internal aerial within the receiver, while at (b) the same circuit is shown as it would be in a receiver in which provision had been made for the use of an external aerial as well, so that the user has the choice of internal or external aerial.

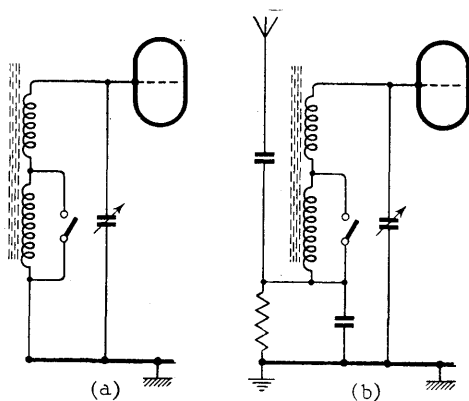

Fig. 5. Two internal aerial systems employing ferrite rod aerials, as indicated by long broken lines. At (a) the aerial is internal only, but at (b) provision is made for capacitive bottom coupling from an external aerial

CHAPTER 3

TUNED INPUT STAGE

The first tuned circuit is always connected, as far as radio frequency signals are concerned, from the control grid of the first valve to chassis. The cathode of the first valve is also connected, either directly or via a bias resistance, to chassis, so that the tuned circuit is connected effectively from control grid to cathode of the valve.

The fundamental arrangement is shown in Fig. 6(a). This shows the aerial coupled to a parallel-tuned circuit using a fixed coil and a variable capacitor. The top of this circuit is connected to the control grid of the first valve, and the bottom is connected to chassis. Since the cathode of the valve is also connected to chassis the tuned circuit is thus connected across the grid/cathode circuit of the valve.

A more practical circuit is shown in Fig. 6(b), which has provision for the application of the bias voltage of the automatic gain control circuit to the grid of the valve, and also for the application of fixed grid bias to the valve. The a.g.c. line, carrying the voltage obtained from a later part of the circuit, is shown beneath the chassis, which is the convention usually adopted in circuit diagrams. The bottom end of the tuning coil, instead of going to chassis, is connected to the a.g.c. line and the voltage is therefore impressed on the grid of the valve via the coil. This is known as a series-fed a.g.c. circuit.

The lower side of the tuning capacitor goes to chassis, as before, merely because this is convenient in manufacture. The frame of the capacitor forms one of its connections, and, by bolting the component to chassis to fix it, the desired connection is automatically made. As the bottom of the coil is connected to the a.g.c. line (which only connects to chassis at the far end via resistors of high values), the coil is not connected directly across the tuning capacitor, and the circuit as described, therefore, would not be efficiently tuned.

It will be noted, however, that there is a fixed capacitor (C1) between the a.g.c. line and chassis. This usually has a value of

the order of 0.01 to 0.05 μF , and as far as radio frequencies are concerned, it is virtually a short circuit, so that from the tuning point of view it can be considered as connecting the bottom of the tuning coil to chassis, and thus completing the tuned circuit.

The principle of the bias arrangement in Fig. 6(b) must now be considered. Resistance R1, in series between the cathode of the valve and chassis, has the total cathode current of the valve flowing through it, that is, the sum of all the currents taken by any other electrodes in the valve. This produces a certain voltage drop across R1, in such a direction as to make the chassis end of R1 negative by a certain amount, relative to the cathode end of R1. The grid of the valve is connected to chassis, so it must have the same d.c. potential as chassis. Its path to chassis goes via the tuning coil, the a.g.c. line and the resistors at the far end of the a.g.c. line. The resistors have a very high value, but no current flows through them normally so there is no voltage drop along them. Since the cathode end of R1 is positive with respect to chassis, therefore, the grid is biased *negatively* with respect to cathode by an amount depending on the value of R1 and the total cathode current of the valve.

In the case of the first valve of the set, which is either an r.f. amplifier or a frequency-changer, R1 will have a low value of about 300 ohms. Nevertheless, it offers an impedance to r.f., and in order to get rid of this, R1 is shunted by C2 (0.05 to 0.1 μF), which effectively connects the cathode of the valve to chassis, as far as r.f. is concerned. Thus, by the use of the by-pass capacitors C1 and C2, the tuning circuit of Fig. 6(b) is made equivalent to that of Fig. 6(a). It was mentioned earlier that Fig. 6(b) showed a series-fed a.g.c. circuit, the control voltage being applied in series through

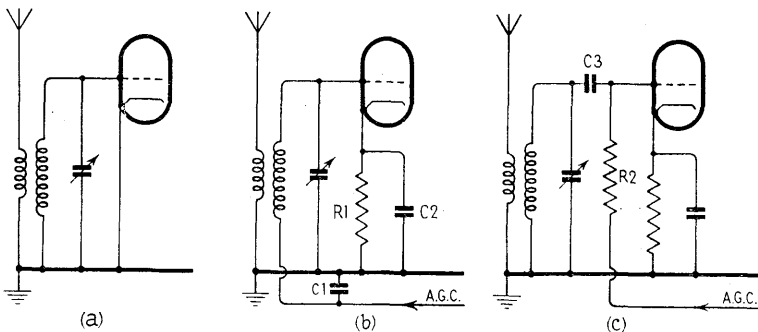

Fig. 6. At (a) is shown the fundamental single-tuned circuit; at (b) series-fed a.g.c. bias and fixed cathode bias are added; (c) shows the alternative parallel-fed a.g.c. bias arrangement

the tuning coil to the grid. Fig. 6(c) shows another method of feeding the a.g.c. voltage to the grid. It resembles the old grid leak and capacitor circuit. The a.g.c. potential is fed via the resistance R2 direct to the grid, while the tuned circuit is isolated from the grid by C3. If C3 were not present, the low d.c. resistance of the tuning coil would have the effect of shorting the grid to chassis and preventing the a.g.c. from working.

C3, of course, is no barrier to the transfer of r.f. voltages developed across the tuned circuit to the grid of the valve. Common values for R2 and C3 of Fig. 6(c) are 1 megohm and $0.005 \mu\text{F}$. Note that when this arrangement is used the tuned circuit may be connected as in Fig. 6(a).

The d.c. connection for the application of the fixed bias to the grid is again obtained by virtue of the fact that the far end of the a.g.c. line is connected via a high resistance to chassis. It may not be out of place here to mention that if at any time it is desired, when testing or aligning a set, to put the a.g.c. circuit out of action, the proper method is to connect the a.g.c. line to chassis. If the line is merely broken the bias connection is removed, and the grid of the valve is left "free", or, as some people describe it, "floating".

A typical arrangement for the first tuned circuit of a three-waveband receiver is shown in Fig. 7. Here separately switched tuned circuits are used for each waveband. C1 is the tuning capacitor, and C5 is the fixed capacitor corresponding to C1 in Fig. 6(b). Although on casual inspection they seem to be in different positions in their respective circuits, in actual fact their positions are electrically identical.

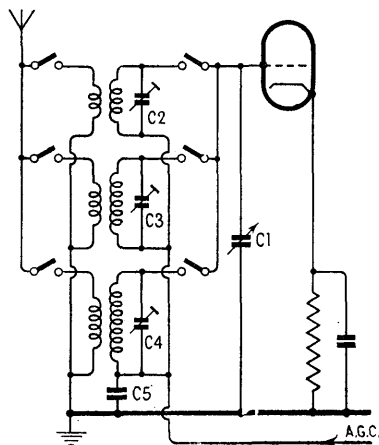

Fig. 7. Representative arrangement of a simple 3-band input circuit employing the principles introduced in Fig. 6

It will be noted that a small variable capacitor is shown connected across the tuning coil of each waveband. These capacitors are for alignment purposes, and in practice the capacitors C2, C3 and C4 are of the pre-set or trimmer type. They are adjusted initially at the factory when the set is made, and subsequently only when re-alignment of the receiver is found to be necessary.

Sometimes the pre-set capacitors are replaced by fixed capacitors of the requisite value, while on one of the bands (usually m.w.) the trimmer may be mounted on the tuning capacitor gang unit and connected directly across one section of it, and will therefore not be shown directly across the coil. Occasionally the trimmer may be omitted altogether from one of the bands.

The single-tuned circuit preceding the first valve has now been covered in adequate detail, but it should be pointed out that variations of the arrangements described are often encountered.

It may not be out of place at this juncture to point out that in modern receivers the waveband switches of all the tuned circuits are ganged together in one unit, so that only one knob is needed to perform all the waveband switching. In this book, however, the switches are shown separately in the circuits which they control, as this makes for simplicity in reading and understanding the circuits.

Trimmers are usually of very small capacitance, and their function is to balance out the "stray" capacitance when the tuning gang is near to its minimum capacitance. This so-called "stray" capacitance exists between all the wiring and chassis, and the designer knows approximately what its value will be, but it varies slightly from set to set. These "strays" do not add up to very much, but when the gang is at its minimum position its own capacitance is very small, and the "strays" contribute significantly to the total tuning capacitance. If they vary from set to set, so will the tuning at the low wavelength end of the scale, and the calibration will be affected. At the high wavelength end, when the gang plates are fully enmeshed, these small effects are virtually swamped and they do not affect the calibration.

So the designer *adds* to the "strays" a small amount of extra capacitance in the shape of trimmers which can be adjusted to ensure that the "strays" and trimmers together total the same value in every receiver. The appropriate trimmer is adjusted at a given frequency near the high-frequency (low-wavelength) end of the tuning range on each waveband to achieve correct calibration at that point, and the "stray" capacitance is thus balanced out to ensure that the wavelength to which the set is tuned is the same as that indicated on the tuning scale.

CHAPTER 4

BAND-PASS COUPLING

Selectivity is a very important factor in receiver design. This means not that the tuning shall be "knife edge" sharp, but that it shall be broad, with well-defined limits at the edges of the band-width covered. It should pass equally all frequencies within, say, plus or minus 5 kc/s of the carrier frequency, but reject sharply others just outside it. In some receivers, particularly those which do not use an r.f. stage prior to the frequency-changer, a double-tuned input circuit may be used to give an extra degree of selectivity. Such circuits are generally of the band-pass type and may take various forms. For instance, to get the correct band-pass effect the two tuned circuits may be inductively coupled, capacitatively coupled, or, using a combination of both methods, "mixed" coupled.

The double-tuned circuit is, of course, designed so that its two sections are ganged together (and with the oscillator stage) for tuning purposes. It therefore needs two sections of a ganged tuning capacitor, and as the oscillator needs one, the tuning capacitor will be of the three-gang type. If an r.f. stage with single-tuned circuits is used, the tuning capacitor will again have three sections, but if there is no r.f. stage, and only the single-tuned input circuit, only a two-gang capacitor is necessary.

In a double-tuned circuit, there is always some form of coupling between the two tuned circuits to enable the signal voltage built up across the first to be transferred to the second, and on the type and degree of coupling depends the response of the complete circuit. With a weak coupling, the circuit will give good selectivity but poor sensitivity; with strong coupling, the reverse is the case.

By suitable coupling arrangements a band-pass effect is obtainable, which means that over a certain band of frequencies on either side of the frequency to which the circuits are tuned the response is at a maximum, while outside this band, on either side, the response falls off rapidly. The ideal curve has a flat top and steeply sloping sides. The effect of a band-pass characteristic of the tuning circuit

is that a high degree of selectivity is obtained without having to sacrifice the quality of reproduction to a serious extent.

Double-tuned circuits can be coupled in several ways, and the methods used in modern receivers will now be considered. The most common method is simple inductive coupling between the two tuned coils, which really form the primary and secondary of a double-tuned r.f. transformer. The circuit is shown in Fig. 8(a), where L1, C1 and L2, C2 are the two tuned circuits, coupled by the mutual inductance between L1 and L2. The coils are usually identical in shape and characteristics, and are wound and mounted so that a certain definite degree of coupling between them is obtained by virtue of the distance by which they are separated.

The next most common type of coupling is capacitive, as shown in Fig. 8(b). Here L3, C3 and L4, C4 are the tuned circuits, each being completed by the fixed capacitor C5, which connects the bottom end of each coil to chassis as far as r.f. is concerned. The coupling between the two circuits is not obtained by the inductive effect of the physical proximity of the two coils, but by the reactance of capacitor C5, which is common to both tuned circuits. The degree of coupling depends on the capacitance of C5, and this is carefully chosen by the designer. It may be anything between 0.01 μF and 0.2 μF .

Capacitor C5 is often referred to as the "bottom coupling" capacitor, owing to its position in the conventional type of circuit. C6 in Fig. 8(b), which is shown dotted, has a very small value (often only a few pF) but is sometimes used in a band-pass circuit, and is referred to as the "top coupling" capacitor.

If L3 and L4 are inductively coupled, and C5 (and/or C6) is used as well, we have a form of "mixed coupled" circuit. The only difference between this and the capacitively-coupled circuit is in

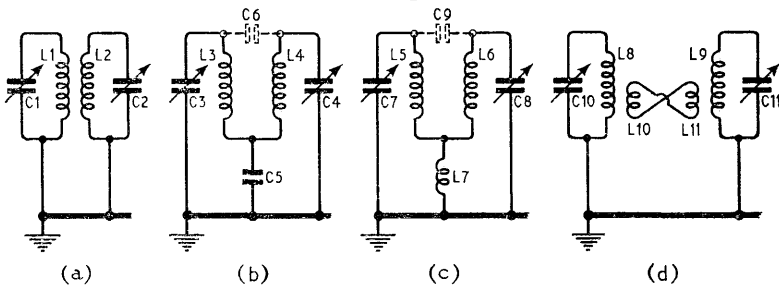

Fig. 8. Showing four basic band-pass couplings. At (a) is the simplest form, using mutual inductive coupling; (b) shows capacitive bottom coupling, possibly with top coupling (dotted); (c) bottom inductive coupling by L7; (d) cross-connected link coupling

the disposition of the coils, but in capacitatively-coupled circuits the coils may be screened from each other to prevent inductive coupling.

Some designers prefer to use the form of inductive coupling shown in Fig. 8(c). This is similar to Fig. 8(b), except that the inductance coil L7 takes the place of the coupling capacitor C5. Coupling is due to the impedance of L7, which is common to both the tuned circuits L5, C7, and L6, C8. L7 is usually a fairly small inductance, and, of course, L5 and L6 need not themselves be inductively coupled. Sometimes they are coupled to a certain degree, however, and this obviously modifies the effect of L7.

In Fig. 8(c), C9 is shown dotted, and indicates the possibility of mixed coupling by using a small "top coupling" capacitor. Another point about Fig. 8(c) is that sometimes a fixed capacitor is interposed between the bottom of L7 and chassis, which also gives a form of mixed coupling. Its main use, however, is to isolate the coils from chassis as far as d.c. is concerned, so that a bias voltage can be fed through L6 to the grid of the following valve by connecting its feeder to the junction of the bottom of L7 and the extra capacitor.

In Fig. 8(d) is shown another form of inductive coupling. An essential function of the various kinds of coupling used is to couple the two circuits with a critical degree of phase difference, and in Fig. 8(d), the coupling coils L10, L11 are shown deliberately cross-connected to achieve the required effect. Except for the phase difference, the two coupling coils could just as well be two low impedance coupling coils between the two tuned circuits, L10 forming a step-down transformer winding to a low impedance transmission line, and L11, L9 forming a similar step-up transformer at the far end of the line.

Band-pass tuning in the first stage of a superhet receiver is quite uncommon, all the desired band-pass characteristics being more easily obtained in the i.f. stages of the receiver. Variably-tuned band-pass circuits require two sections of a capacitor gang to themselves, making necessary with the oscillator circuit a three-gang unit altogether, and their use was more common with t.r.f. receivers. Where a three-gang capacitor unit is used with a superhet, it is usually to accommodate an r.f. amplifying stage.

It should be pointed out that the diagrams given are the basic ones and for a single waveband only. With two wavebands, switching, trimming capacitors, and often separate bottom coupling capacitors for each band, the circuit often becomes quite elaborate, though it can usually be broken down to one of the forms in Fig. 8. Fig. 9 shows a practical form of band-pass tuning as used in a three-band receiver. Here it will be noticed that double-tuned circuits

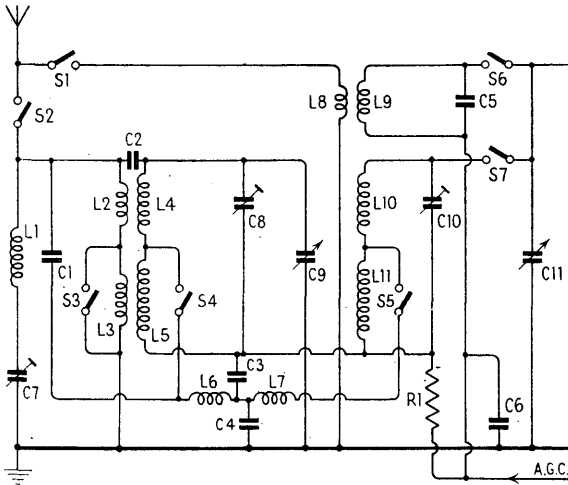

Fig. 9. A practical 3-band aerial tuning circuit incorporating a double-tuned band-pass circuit for m.w. and l.w. On s.w. a single-tuned circuit is employed

are used on m.w. and l.w. only. On the s.w. band the aerial is coupled by L8 to the single-tuned circuit L9, C11. C5 is the s.w. fixed trimmer.

On m.w. and l.w. the aerial is coupled by L2 and L3 (and the small coupling capacitor C2) to the first tuned circuits L4, C9 (m.w.) and L4, L5, C9 (l.w.). L6 and L7 are two small coils, which are mutually coupled and are used for inductive coupling, while C3, C4 are bottom coupling capacitors between the band-pass primary coils L4, L5 and the secondary coils L10, L11. On l.w. only L6 and L7 modify the coupling between the band-pass coils by introducing an inductive element.

On m.w. switches S4, S5 are closed, so that coupling between L4, C9 and L10, C11 is by L6 (with L5 and C3 in parallel) and L7 (with L11 and C3 in parallel). The effect of C4 has to be allowed for, but it is present only for d.c. isolation.

On l.w., S4 and S5 are open, so that one end of L6 and of L7 is disconnected from the tuned circuits, and band-pass coupling is capacitive only, by C3 and C4 in series.

Other points of interest in the circuit shown are the i.f. filter L1, C7 (already mentioned when dealing with aerial circuits) and the a.g.c. feed circuit. On the s.w. band the a.g.c. is fed through coil L9, and C6 connects the bottom of the coil to chassis as far as r.f. is concerned.

CHAPTER 5

R.F. AMPLIFIER STAGE

Having dealt with the tuned input circuits of a modern superhet one reaches the first valve of the receiver. In the majority of cases this will be the frequency-changer valve, but since a few receivers employ a stage of r.f. amplification in front of the frequency-changer, this will be considered first.

The type of valve used for r.f. amplification is usually an r.f. pentode or tetrode having a variable-mu characteristic, which means that its gain can be adjusted by altering the bias applied to the control grid of the valve. In circuit diagrams the variable-mu type of valve is usually indicated by an inclined arrow drawn

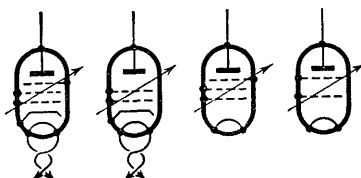

Fig. 10. Conventional diagrams for variable-mu r.f. valves. Left to right: i.h. pentode, i.h. tetrode, d.h. pentode, d.h. tetrode

through the valve diagram. Fig. 10 shows the standard diagrams used for r.f. pentodes and tetrodes of the indirectly heated and directly heated (battery) types.

The gain of the r.f. valve is almost invariably controlled by the a.g.c. voltage mentioned in an earlier section, and that is why a variable-mu valve is essential in this position. The bias voltage derived from the a.g.c. circuits is fed to the control grid of the valve as explained when dealing with tuned input circuits.

In addition, a small fixed negative automatic bias may be used, so that however weak the signal (and therefore however small the negative a.g.c. voltage) the valve always has a certain fixed minimum bias. This bias is obtained by means of a fixed resistor in the lead from the cathode of the valve to chassis in the case of indirectly

heated valves, or from a potentiometer network in the case of a battery receiver.

The other power supplies for the valve (apart from the filament or heater current) are a positive anode voltage and a positive screen voltage (usually, but not always, lower than the anode voltage). The control grid is the innermost grid (next to the cathode), while the screen grid is next to the control grid. In a tetrode the only remaining electrode is the anode, but in a pentode there is a third grid, between the screen grid and anode. This is the suppressor, and is usually connected direct to chassis, or to the cathode of the valve.

The screen grid obtains its voltage from the h.t. supply, usually via a decoupling resistor which may have a value up to 50,000 ohms or more. A common value is 25,000 ohms. Alternatively, the

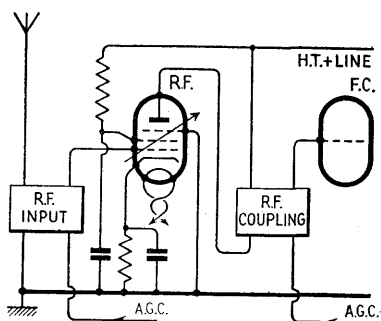

Fig. 11. A complete r.f. stage with the couplings indicated by square blocks

screen voltage may be obtained from a potentiometer consisting of two resistors in series across the h.t. supply from h.t. positive to chassis. The screen voltage will then be tapped off from the junction between the two resistors.

In whatever way the screen obtains its supply, there will almost invariably be a fixed capacitor, for r.f. by-pass purposes, connected from the screen to chassis. This capacitor will usually have a value of about $0.1 \mu\text{F}$.

So much for the d.c. supplies of the r.f. valve. The r.f. signal voltage, as we have already seen, is fed via the tuned input circuit (which may be of any of the types already described) to the control grid circuit of the valve, and the amplified signal appears in the anode circuit. From this point the signal must be passed on to the next stage in the receiver, namely the frequency-changer. For this purpose some form of coupling between the anode circuit of the r.f. valve and the grid circuit of the frequency-changer valve must

be used, and this is indicated in the diagram in Fig. 11, where a complete r.f. stage with skeleton couplings is shown.

It would, of course, be possible to employ an untuned form of coupling of the resistance-capacitance or choke-capacitance type, but in order to secure maximum amplification over the whole band, and to obtain an extra degree of selectivity, the inter-valve coupling is usually tuned. In some cases, however, an untuned or aperiodic form of coupling has been used in certain receivers.

Three common forms of coupling are used in modern sets, namely tuned-secondary transformer coupling, tuned anode coupling, and choke-fed tuned grid coupling. The three are listed in their order of popularity, and where an r.f. stage is employed, the first-mentioned form is the one most likely to be used.

In Fig. 12 are shown the three types of coupling in their simplest form. Fig. 12(a) indicates tuned-secondary transformer coupling. The primary of the transformer (L1) is in series with the anode circuit of the r.f. valve, and is coupled to the secondary (L2), which is tuned by C1. The signal across the tuned circuit is then applied between the grid of the next valve and chassis. It will be observed that this arrangement is very similar to that of the tuned input circuit of the receiver, with the primary of the transformer taking the place of the aerial coupling coil. Similar arrangements are made for applying the a.g.c. voltage via the tuned circuit to those described in the section on the tuned input stage.

Fig. 12(b) shows the tuned-anode type of coupling, in which the tuned coil L3 is in series with the anode circuit. Sometimes the h.t. line is connected to a tapping on L3 to minimize damping of

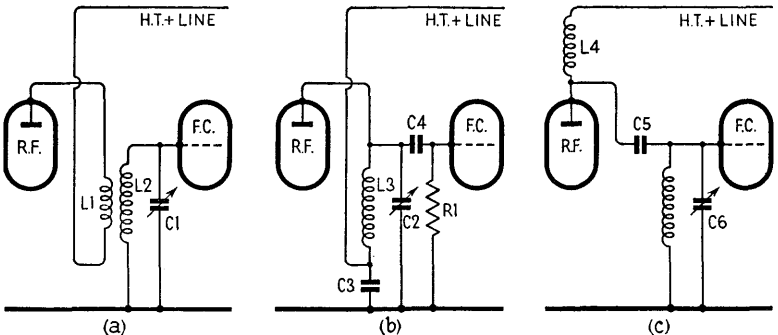

Fig. 12. Three forms of coupling between an r.f. amplifier and the frequency changer. At (a) is shown tuned secondary transformer coupling; at (b) tuned anode coupling; and at (c) choke-fed tuned grid coupling. Only a single wave-band is indicated in each case

the tuned circuit. It will be noted that the tuning capacitor C2 is not directly across the coil, although, as far as r.f. is concerned, it is in parallel with it by virtue of the capacitor C3, connected from the coil to chassis. C4 is a grid capacitor isolating the anode voltage of the r.f. valve from the grid of the following valve, but not preventing the r.f. voltage from reaching the grid. R1 is a resistance permitting bias to be applied to the grid. Since in this circuit almost the full h.t. voltage is applied across the tuning capacitor, a 0.1 μ F blocking capacitor will sometimes be found between the top of L3 and the top of C2.

Fig. 12(c) shows the third form of coupling, but this is not very common. L4 is an untuned r.f. choke in the anode circuit of the r.f. valve. C5 is the coupling capacitor from the r.f. anode to the frequency-changer grid. C6 and the coil across it form the tuned grid circuit.

In their complete practical forms the couplings will, of course, incorporate waveband switching and trimmer capacitors somewhat like these arrangements in the tuned input circuit of Fig. 7.

It must be borne in mind throughout these descriptions that when reference is made to a coil, for instance, being connected in series the anode of a valve, as in the case of L3 in Fig. 12(b), that this is merely a descriptive term for that particular method of feeding high tension current to the valve. In fact, from an r.f. point of view, L3 is in parallel with the anode circuit of the r.f. valve. It is connected between the anode and (via C3) chassis (or earth) and the cathode of the valve. It is directly connected to the h.t. positive line, which is returned to chassis through quite large as well as small capacitors. It must always be remembered throughout that the h.t. positive is as "earthy" as chassis with respect to both r.f. and a.f. signals.

CHAPTER 6

FREQUENCY-CHANGING

Having now followed the superhet circuit up to the signal grid of the frequency-changer stage (and so far there has been practically no difference in the circuit from that of a "straight" receiver, except that a.g.c. is rarely used in the latter), it is now necessary to look into the principles of frequency-changing, on which the whole structure of the superhet circuit depends.

In the frequency-changer stage the incoming signal is mixed with the output of a local oscillator to produce the required fixed intermediate frequency. Thus there are two sections to be considered in the frequency-changer stage—the mixer and the oscillator. Usually the two functions are combined in a single valve, which may have a single cathode stream, as in the heptode (or pentagrid) or two separate cathode streams (obtained from a single cathode), as in the triode-hexode. In the latter case we have virtually two separate valves in a single envelope. It is quite possible to use two entirely separate valves in the frequency-changer stage, and this is actually done in certain receivers. A triode is then used as the oscillator and usually a pentode, hexode or heptode as the mixer.

The output of the frequency-changer, at intermediate frequency, appears in the anode circuit of the mixer section, whence it is fed to the next stage of the receiver, the intermediate frequency amplifier, which will be dealt with later.

Let us now consider in a little more detail what happens in the frequency-changer. We have seen that the incoming signal is fed from the aerial circuit to a tuned input circuit, and thence either direct, or via a pre-selector stage of r.f. amplification, to the frequency-changer. The actual electrode to which it is fed is known as the signal grid, and its position in the valve depends on the type of valve which is used. In any case, the signal modulates the cathode stream of the mixer section of the valve.

At the same time, the output from the oscillator section of the frequency-changer stage is also injected into the mixer section of

the stage, and also modulates the cathode stream of the mixer. The effect of this (which in some respects is similar to the production of "beats" in audio-frequency engineering) is to produce in the anode circuit of the mixer signals of various frequencies.

The main frequencies so produced are one equal to the difference between the signal and oscillator frequencies; one equal to the sum of the signal and oscillator frequencies; the original signal frequency; and the original oscillator frequency.

In addition, other frequencies will be present, produced as a result of the combination of the fundamentals and harmonics of the signal frequency and the oscillator frequency.

Out of all these frequencies one only is required, and that is the difference between the signal and oscillator frequencies. All the others are undesired and fortunately they are sufficiently different from the desired frequency to be blocked or filtered out by the i.f. amplifier, which will have fairly sharply tuned circuits.

To take a concrete numerical example, we can assume a signal frequency of 1,000 kc/s (300 metres), and an oscillator frequency of 1,470 kc/s. The four main frequencies present in the anode circuit of the mixer will be: Difference, 470 kc/s; sum, 2,470 kc/s; original signal, 1,000 kc/s; oscillator, 1,470 kc/s.

Of these, the 470 kc/s signal is the desired intermediate frequency, and it will be appreciated that if the four frequencies are passed to the i.f. amplifier, which will be tuned to 470 kc/s, the unwanted signals of 1,000, 1,470 and 2,470 kc/s will not get through.

There is another point to be noticed, however. In the example chosen the oscillator frequency is higher by 470 kc/s than the incoming signal frequency. But suppose a signal of 1,940 kc/s reaches the grid of the mixer when the oscillator is producing a signal of 1,470 kc/s. A difference frequency of 470 kc/s will again be produced, and this will also be amplified in the i.f. stage.

This is known as an "image" signal, and it produces interference in the receiver if the wanted signal of 1,000 kc/s and the signal of 1,940 kc/s are of anything like comparable strength. With a well-designed receiver image interference is negligible. If the input circuits are sharply tuned, and particularly if a pre-selector stage is incorporated, the 1,940 kc/s signal will be automatically removed when the input circuits are tuned to 1,000 kc/s, and thus prevented from reaching the frequency-changer.

In view of the fact that the frequency which produces an image differs from the wanted signal frequency by twice the intermediate frequency ($1,940 - 1,000 = 2 \times 470$), it will be appreciated that with a low value of intermediate frequency there is more chance

of image interference. For instance, with an i.f. of 110 kc/s the signal producing an image is only 220 kc/s away from the wanted signal, whereas, as has been seen, with an i.f. of 470 kc/s it is 940 kc/s away.

That is largely the reason why a high value of intermediate frequency is chosen for modern receivers, particularly in cases where there is only one tuned circuit in front of the frequency-changer.

It will be noted that in the numerical example quoted earlier the oscillator frequency was assumed to be higher than the signal frequency. As a matter of fact, it practically always is, but for a definite reason.

It will be obvious that, with a signal frequency of 1,000 kc/s, an oscillator frequency of 530 kc/s would produce the required intermediate frequency of 470 kc/s and it might be thought immaterial whether the oscillator frequency were made higher or lower than the signal frequency. Actually, the higher oscillator frequency is necessary for reasons connected with the tuning of the circuit.

Suppose the wavelength range of the set on the m.w. band is 200–500 metres. This is equal to 1,500 to 600 kc/s, a frequency range of 2.5 to 1, which can be covered satisfactorily in a single band with a standard tuning capacitor.

If the oscillator frequency is always higher than the signal frequency, and assuming an intermediate frequency of 470 kc/s, the oscillator will have to tune from 1,970 to 1,070 kc/s, a frequency ratio of about 1.9 to 1, which is also easily covered in a single band.

If, however, the oscillator frequency is always below the signal frequency, the oscillator will have to tune from 1,030 to 130 kc/s, a frequency ratio of 7 to 1. To cover this wide frequency range in a single band is impossible by any normal tuning method, and for this reason it is necessary to arrange for the oscillator frequency to be higher than the signal frequency. Incidentally, this explains why, when the oscillator circuit of a receiver is aligned, in cases where two “peaks” or tuning points are noticed, that having the higher frequency is usually the correct one.

The other one corresponds to the oscillator frequency when it is lower than the signal frequency, and the frequency separation between the two is twice the value of the intermediate frequency of the receiver. Another expression sometimes used for “image frequency” is “second-channel frequency”.

CHAPTER 7

OSCILLATOR ARRANGEMENTS

Although there are many types of frequency-changer circuits, we have already seen that they have a number of features in common. In all cases they consist of an oscillator and a mixer section, both the output of the oscillator and the signal input being fed into the mixer, where they produce the required intermediate frequency signal.

In considering the oscillator section first of all, it may be pointed out that in practically all cases a triode oscillator circuit is employed but the triode valve itself may be a separate triode section of the frequency-changer valve, or it may be part of a multi-electrode assembly forming the complete mixer valve. It is separate in a double-system (or double-section) valve such as a triode-pentode or triode-hexode, but it may be formed of the cathode and two adjacent grids of the frequency-changer valve, as in a heptode or an octode. With the latter the grid adjacent to the cathode is the oscillator control grid, and the next grid acts as the oscillator anode.

The circuit used for the oscillator often consists of the familiar tuned coil to which is inductively coupled a "reaction" coil. The coupling is fixed, and the size of the coil and the degree of coupling is arranged by the designer to secure self-oscillation of the circuit over the whole of the waveband. The tuned coil may be either in the grid or the anode circuit of the oscillator, while the oscillator anode h.t. feed may be by one of two different methods. Typical skeleton circuits on the lines mentioned are shown in Fig. 13 (a)-(c). Taking Fig. 13(a) first, this shows the tuned grid oscillator circuit with a parallel-fed anode circuit. It will be noticed that the grid is returned to chassis via the grid resistance R_1 . In practice, where there is a bias resistance in series with the cathode lead of the valve to chassis, R_1 will be returned to the cathode of the valve, and not to chassis. This applies to all the circuits shown.

When a valve oscillates, d.c. current flows through the grid resistance from cathode to grid. It is said to "leak" through the

resistance, which is therefore called a "grid leak". As the current flows through the resistance, it causes a voltage drop to occur between the ends of the resistance, and this provides the grid bias potential for the valve.

C2 is the grid capacitor, which is always present when R1 is used. Typical values for R1 and C2 are 50,000 ohms and 0.0001 μ F. L1, C1 form the tuned circuit, only a single waveband being shown in this and the other diagrams. L2 is the oscillator reaction coil, coupled inductively to L1, and capacitatively by C3 to the oscillator anode. The anode is fed with d.c. from the h.t. line via R2, which must always be present, and this breaks down the full h.t. voltage to a suitable lower value for the oscillator anode.

Actually R2 has to be chosen to suit the valve and circuit, in order to secure the correct degree of oscillation over the whole waveband. If the h.t. voltage on the anode were too low, dead spots might be produced owing to the oscillator's ceasing to function on certain parts of the band; on the other hand, with too high an anode voltage, there is the possibility of harmonics being produced in the oscillator circuit, which will be productive of interference whistles in the receiver, and this must be avoided.

The circuit of Fig. 13(b) is similar to that of Fig. 13(a), but here the anode circuit L4, C5 is tuned, reaction being applied in the grid circuit by L3. As before, the anode circuit is parallel-fed.

Fig. 13(c) shows the other form of tuned grid oscillator circuit, in which a series-fed arrangement for the h.t. circuit is employed.

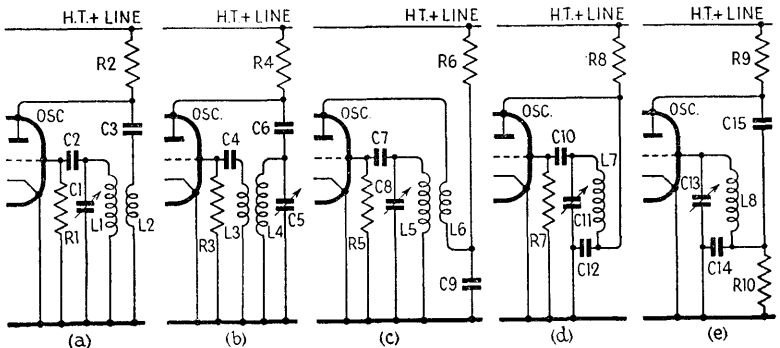

Fig. 13. Five simplified examples of oscillator circuits:

- (a) Tuned grid, with parallel-fed anode circuit
- (b) Tuned anode, with parallel-fed anode circuit
- (c) Tuned grid, with series-fed anode circuit
- (d) and (e) are two examples of tuned grid circuits with capacitively-coupled anode reaction

L5, C8 is the tuned circuit, and L6 is the anode reaction coil. The h.t. supply is now fed via R6, through L6 to the oscillator anode, so that the anode current of the valve actually flows through the anode coil. C9 (in conjunction with R6) provides decoupling for the oscillator anode circuit.

Occasionally it will be found that from the junction of R6 and C9 a lead will be taken for the h.t. supply to the screen of the mixer, or the screen of the following i.f. valve, or both.

Although the three oscillator circuits shown in Fig. 13 (a)–(c) are fairly common ones in modern sets, they are not the only ones which may be encountered. Some designers dispense with a separate reaction coil, and use in its place capacitive coupling produced by a capacitor which is common to both the grid and the anode circuits of the oscillator.

One example of this is shown in Fig. 13(d). R7 and C10 are the grid leak and grid capacitor respectively, while L7, C11 are the tuning coil and capacitor respectively. The extra capacitor C12 (which is shown fixed, but may be pre-set) will be noticed. This is primarily employed as a tracker (or in America, a padder) to keep the oscillator circuit out of step with the signal circuit by a constant amount (equal to the intermediate frequency).

The problem of the tracker will be considered later, but meanwhile it is clear that C12 is common to the grid and the anode circuits of the oscillator. The grid circuit is via C10, L7 and C12 to chassis; the anode circuit is via C12 to chassis. C12 is, therefore, common to both, and the two circuits are thus coupled.

The value of C12 is fixed by considerations of its use as a tracker, but it usually has a sufficiently large value, in conjunction with a suitable oscillator anode voltage, to produce the requisite degree of oscillation over the whole waveband. Often, however, a combination of reaction coil and common capacitor will be found, when the capacitor would be inserted between L1 and chassis in (a), for instance, the bottom of L2 being connected to the junction of the capacitor and L1 instead of going to chassis.

Since R8 and the oscillator anode are isolated (as far as d.c. is concerned) from chassis, there is no need for a blocking capacitor between the bottom of R8 and the bottom of L7, though sometimes one may be present.

Fig. 13(e) shows another variation of the single coil oscillator circuit, in which it is to be noted that the usual grid leak and capacitor are omitted. L8, C13 is the tuned circuit, with C14 as tracker and common capacitance in grid and anode circuits. R10 is used in place of the normal grid leak, while C15 prevents leakage of the

h.t. supply to chassis and also blocks the anode voltage from getting to the oscillator grid via L8.

When a valve oscillates, grid current flowing can only flow into the grid capacitor and down the grid leak. But for this leakage it would charge up the capacitor until it choked the grid, but the values of the two components are chosen to give the correct rate of discharge, or time-constant. As the current flows through the grid leak, a potential difference or voltage drop occurs, and the grid becomes negatively biased. It is therefore essential to have a grid leak and grid capacitor somewhere in the grid circuit to chassis, but it can be located at either end of it.

The arrangements of Fig. 13(d) and (e) constitute what is virtually a Colpitts oscillator circuit, the basic arrangement of which is shown in Fig. 14, where the components have been given the same numbers as they have in Fig. 13(d). Derivatives of the basic Colpitts circuit are used in modern receivers more frequently than any other, and it is useful to be able to recognize them in a diagram.

Another arrangement for the oscillator circuit is to use a single tapped coil for tuning and reaction, the reaction section being a continuation of the section which is tuned. It will sometimes be found that the reaction circuit contains a resistor in series or parallel with the reaction coil on one or more wavebands. This is done to modify the reaction effect in certain respects, for instance, to level out the strength of the oscillations over the whole waveband.

The circuits in Fig. 13 show only one waveband, but for multi-waveband receivers the principles are the same, though extended to use extra coils, trimmers and trackers, with switches to select the correct coils and associated components for each waveband. There is, however, a tendency in small modern receivers to use a single oscillator circuit for m.w. and l.w. bands, a large capacitor being shunted across the tuning coil for l.w. operation in addition to the existing trimmers and trackers.

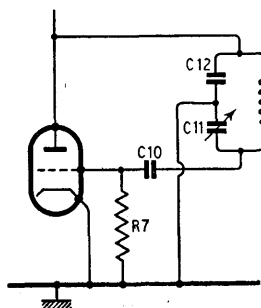

Fig. 14. The oscillator circuit of Fig. 13 (d) is redrawn here to show its derivation from the classical Colpitts circuit—which is characterized by the tuned circuit connected between anode and control grid, with a capacitive tapping point to chassis

CHAPTER 8

EARLY F.C. CIRCUITS

Having followed the incoming signal up to the point where it is applied to the frequency-changer, and having also considered the circuit arrangements of the oscillator section of the frequency changer, it is now necessary to see how the signal voltages and the oscillator voltages are applied to the various types of frequency-changer valves in order to produce the required intermediate frequency voltage.

In very early superhets in this country a screened r.f. tetrode or screened r.f. pentode was used as the frequency-changer, and it was often termed the "first detector", since it made use of its square-law detector characteristic to effect a combination of the two frequencies applied to it and thus to produce the required intermediate frequency. It is not proposed to go into the theory of the operation of this type of frequency-changer here, because it is quite complicated. In any case, the student will not come into contact with many receivers incorporating this style of circuit, which had lost its popularity very many years ago, owing to the introduction of specialized valves for frequency-changing, which gave far superior results in many respects.

However, for the sake of completeness, a typical schematic circuit using a screened tetrode is given in Fig. 15. Here it will be seen that the signal input goes to the control grid of the valve, while the oscillator section consists of a parallel-fed tuned anode coil inductively coupled to a reaction coil, in the cathode circuit of the valve, so that the oscillator voltages produced in it appear on the cathode of the valve, and thus modulate the cathode stream. The required intermediate frequency signal appears in the anode circuit of the valve, where it is picked out from the several other frequencies by the i.f. circuit (shown as a block), which is tuned to the correct frequency. From here the i.f. signal is fed to later stages.

In the case of battery receivers, coupling coils were introduced in series with the filament circuit of the first detector, and there was

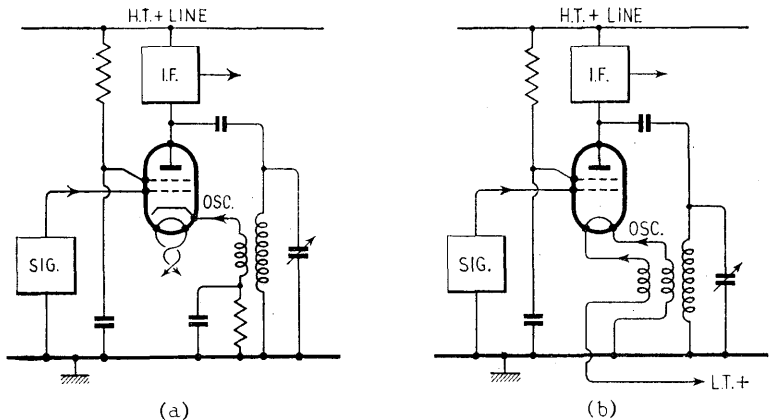

Fig. 15. On the left at (a) is seen a typical early tetrode frequency-changer circuit in an a.c. mains receiver with oscillator coupling between anode and cathode. At (b) is shown how the same principle can be applied to a battery valve, with a directly-heated cathode

usually one coil in each filament lead, as shown in the right-hand diagram of Fig. 15. Obviously, in this case the coils had to be of fairly heavy gauge wire in order to keep their resistance low so that it had a negligible effect on the voltage reaching the filament.

Sometimes, in cases where a screened r.f. pentode was employed, the oscillator coupling coil was in series with the screen circuit, thus giving screen or suppressor injection of the oscillator frequency. Such circuits were not very common, however.

One of the first multiple valves to be used for frequency-changing was the original type of triode-pentode. This consisted virtually of two entirely separate valves in a single glass bulb, the only part common to both sections being the heater/cathode system. A similar performance could be, and sometimes was, achieved by using two separate valves, a triode acting as oscillator and a screened pentode as mixer.

The schematic circuit of the original type of triode-pentode is shown in Fig. 16(a). It will be seen that the two sections of the valve are quite separate except for the heater and cathode. The signal voltage is fed to the control (first) grid of the pentode. The screen (second grid) is fed as usual from a resistance, while the suppressor (third grid) is connected externally to the cathode of the valve.

The oscillator section has a parallel-fed tuned anode coil, coupled to another coil in the *cathode* circuit of the valve, and cathode injection of the oscillator signal is thus used. The oscillator grid

(grid of the triode) is connected via the grid resistance R_1 and the parallel grid capacitor C_1 to the bottom of the cathode coil, this point being connected via the bias resistance R_2 and by-pass capacitor C_2 to chassis. The i.f. signal appears in the anode circuit of the pentode mixer section.

The circuit of the later type of triode-pentode is shown in Fig. 16(b) for comparison. The battery version is shown because it was in this form that the valve was most used. It will be observed that (apart from the difference between the heater/cathode and filament circuit) there is an important difference between the two valves, namely, that in the later type there is an internal connection between the two sections, the oscillator grid being connected to the pentode suppressor. The coupling between the two sections is thus performed internally, and the system is said to operate by suppressor grid injection.

As no external coupling is necessary, the oscillator circuit therefore differs from that of Fig. 16(a). It will be seen that as shown the oscillator has a tuned-grid circuit, with parallel-fed reaction coupling, but almost any of the circuits described in the preceding section on oscillator arrangements could be used.

Before proceeding to later developments in the type of frequency-changer which uses what are virtually two separate valves in the same envelope, there is one important type which does not come under

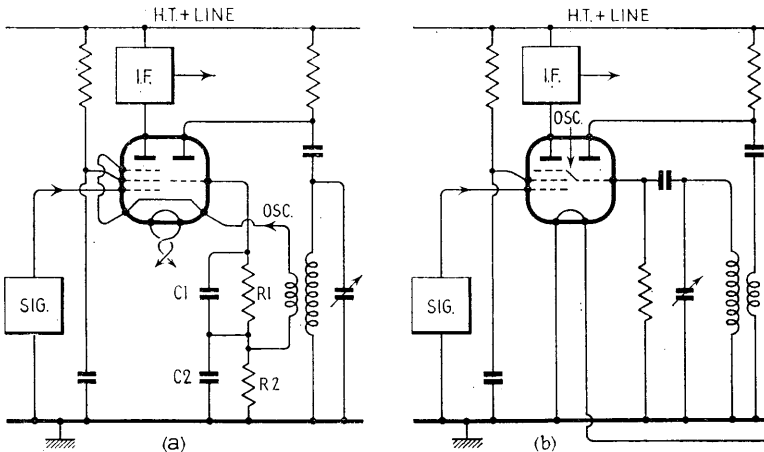

Fig. 16. Two examples of the use of the triode-pentode valve as a frequency changer. At (a) is shown the original type of mains valve; at (b) the battery version. Either might have an internally connected suppressor grid

this heading, and which was extremely popular for a number of years. With the introduction of new types of valves, it was temporarily superseded, but it was brought into use again, in "all dry" receivers, that is, those operating entirely from dry batteries.

The valve is the heptode (formerly called the pentagrid), and as its name suggests, it has seven electrodes (counting the filament or heater/cathode assembly as one), of which five are grids. Often in modern "all dry" battery valves, and indeed in an early 2V accumulator valve, there was also a suppressor grid, making six grids, or

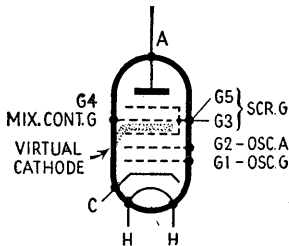

Fig. 17. Diagram of the electrode system of a heptode frequency-changer

eight electrodes in all, and the valve then became an octode. Either valve, of course, employs a single electron stream, which distinguishes it from the type of frequency-changer which has two separate electrode systems and two electron streams.

Coupling between the incoming signal and the local oscillator occurs in the electron stream of the valve, and therefore the valve is said to employ electron coupling, instead of the electrode injection system used in most of the dual types of frequency-changer valves. A diagram of the valve, showing the various electrodes, appears in Fig. 17.

Of the various grids in the heptode frequency-changer, the first (nearest the cathode) is the oscillator control grid, while the second acts as the oscillator anode, so that the oscillator section is really of the triode type. In addition, however, the oscillator anode acts as the modulating electrode for the electron stream. Grids 3 and 5 are connected together inside the valve and form screens, the third grid screening the oscillator section of the valve from the mixer section.

The fourth grid is the mixer control grid, to which the incoming signal is applied; next comes the fifth (screen) grid already mentioned, then finally the mixer anode, in whose circuit the i.f. signal appears. In an octode valve there would be another (suppressor) grid between the fifth grid and the mixer anode. It will be noted that the mixer section has no actual cathode, but utilizes the electron "cloud" which forms between grids 3 and 4 as a virtual cathode.

Fig. 18. Circuit arrangement employed with a heptode frequency-changer

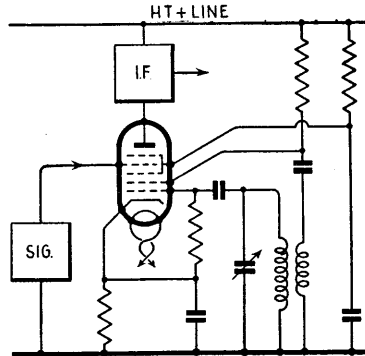

This cloud is due to a proportion of the electrons which escape through grid 2 (the oscillator anode) in pulses determined by the frequency of the oscillator. They are attracted through the screen grid 3, and supply the operating power for the mixer section of the valve.

Since the electrons arrive in pulses from the oscillator section with a frequency determined by the oscillator circuit, the virtual cathode of the mixer is similarly varying, and so modulates the mixer section of the valve at the oscillator frequency to produce the required intermediate frequency. It should be noted that there is no external coupling between the oscillator and mixer sections of this type of valve.

The external circuit of this type of valve does not differ greatly from that of the triode-pentode circuit of Fig. 16(b). It is shown in Fig. 18, with the tuned-grid type of oscillator circuit, although any of the arrangements already described may be employed. The signal voltage is fed to the fourth grid. The oscillator anode (grid 2) receives its anode voltage from the h.t. line via a dropping resistance; the screens are similarly fed from another resistance, which is provided with a decoupling capacitor to chassis. Occasionally

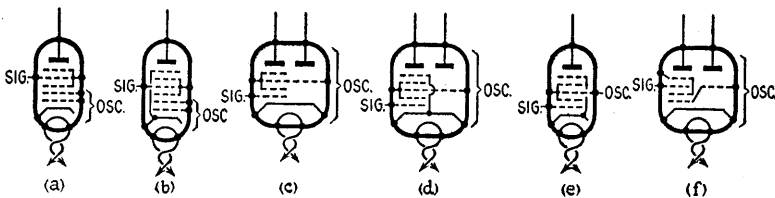

Fig. 19. Six examples of valves used for frequency-changing: (a) heptode; (b) octode; (c) triode-hexode; (d) triode-heptode; (e) 6L7 heptode mixer; (f) 6K8 triode-hexode

the oscillator anode and the screens are fed from the same resistor, but then a series-fed anode circuit would have to be used.

The heptode frequency-changer attained wide popularity, and so did the octode. In the latter the additional grid is used as a suppressor, and modifies the characteristics of the valve. It is connected internally to the cathode of the valve, and therefore does not produce any complication in the circuit. The symbol for a mains heptode is shown at (a) in Fig. 19, while at (b) the octode is shown to enable the electrode systems in the two to be compared. At (c), (d), (e) and (f) are shown the diagrammatic symbols for other types of frequency-changer referred to in this and the next chapter.

CHAPTER 9

LATER F.C. VALVES

Turning now to later types of frequency-changers with double electrode systems and two electron streams, we come to the triode-hexode, which logically follows the later type of triode-pentode mentioned in the last section. The electrode arrangement of the triode-hexode is shown in Fig. 19(c). It will be seen that the hexode mixer section has the input signal applied to the first grid. Grids 2 and 4 are internally connected, and form screens. Grid 3 is the oscillator injection electrode, and is internally connected to the grid of the triode section of the valve (oscillator grid).

Apart from the differences inside the valve, the circuit of a triode-hexode frequency-changer is similar to the triode-pentode circuit shown in Fig. 16(b).

It is quite possible to use a separate triode oscillator and an r.f. hexode mixer as a two-valve frequency changer. The circuit arrangement is the same as when a dual valve is used, except that a connection from the grid circuit of the triode to the third grid of the hexode serves to inject the oscillator voltage into the mixer. The second and fourth grids of the hexode are connected together externally and are used as screens, as in the dual valve.

Another dual valve is the triode-heptode, of which the electrode arrangement is shown in Fig. 19(d). The only difference to be noted is the extra suppressor grid, connected internally to the cathode of the valve.

The triode-heptode circuit can also be employed with separate valves, a triode oscillator and a heptode mixer. A mains heptode (the 6L7G) was produced in America especially for this purpose. Its electrode arrangement is shown in Fig. 19(e), and the valve must not be confused with the ordinary heptode frequency-changer (cf. Fig. 17 and Fig. 19(a)). It will be observed that the 6L7G mixer is identical with the heptode section of Fig. 19(d). One way of using it is to couple the anode circuit of a separate triode oscillator to the injector grid (grid 3) of the heptode via a capacitor.

Finally to complete this review of frequency-changers, mention must be made of another type of triode-hexode, the 6K8, which had a period of popularity. This has a cathode, entirely surrounded by a grid, and two anodes, one on each side of the cathode. The grid surrounding the cathode acts as the oscillator grid on the side nearest the oscillator anode, and as a modulating grid on the opposite side of the cathode, where it forms the first grid of the mixer. Next comes a screen entirely surrounding the signal grid (being thus equivalent to two ordinary screens connected together), and finally the mixer anode. It is not easy to show this form of construction correctly in an ordinary valve diagram, but that shown in Fig. 19(f) is as clear as any.

The point to be noticed with regard to all these types of frequency-changers is that from the operational point of view the external circuit does not vary to any considerable extent, the differences lying mainly in the connections to the particular valve employed. The only exceptions to this are the very early types of valve where external coupling coils were necessary. Of course, the constants of the circuits vary from valve to valve, but this is a matter for the designer rather than the student or service technician.

CHAPTER 10

OSCILLATOR TRACKING

It was pointed out in the section dealing with the principles of frequency-changing that in order to produce the desired intermediate frequency signal in a superhet receiver the oscillator circuit must be tuned to a frequency differing from the signal frequency by a constant amount equal to the value of the intermediate frequency of the receiver, and that usually the oscillator frequency will be higher than the signal frequency.

Consequently, as one tunes over each waveband with the signal-frequency tuning capacitor, the oscillator tuning must be varied at the same time, so that the constant difference in frequency is maintained. Naturally, in a modern receiver where one-knob tuning is essential, the signal-frequency and oscillator tuning capacitors must be ganged so that they rotate together.

At first sight it might seem a simple matter to ensure a constant frequency difference between the two circuits over the whole waveband, but actually it is quite a difficult problem. Using two variable capacitors of the "straight-line-capacitance" type, and arranging for the moving vanes of one to be displaced relative to those of the other by a certain amount gives a constant difference of capacitance over the whole tuning range, and by suitably adjusting the displacement the desired frequency difference between the two tuned circuits can be secured *at one point on the scale*, and at this one point only.

This is because the frequency of a tuned circuit is, for a given coil inductance, inversely proportional to the square root of the capacitance of the tuning capacitor. In other words, a difference in capacitance which produces a certain frequency difference at one setting of the ganged capacitors does not produce the same frequency difference at any other setting.

One way of getting over this difficulty is to use a special gang capacitor with plates shaped in such a way that the frequency difference between the two tuned circuits is the same at every setting

of the gang. This is a solution which is sometimes employed, and where it is used the difference is quite obvious if you compare the oscillator section with the other section(s).

It will often be found that the oscillator section is somewhat smaller, and has vanes shaped differently from those of the section(s) tuning the signal-frequency portion of the set. Sometimes the moving vanes are altered in shape, while in other cases the fixed vanes are altered.

However, specially shaped plates are not a complete solution of the problem. For one thing, a certain shape will only give the constant frequency difference on one waveband; it fixes the frequency difference (and hence the intermediate frequency of the receiver); it is only applicable to a certain value of oscillator tuning coil inductance; and it will be upset by changes in stray capacitances and inductances in the circuit.

None of these disadvantages, except the first, is serious in a commercial mass-produced receiver, which can be designed round the capacitor, and will not vary in its constants to any appreciable degree. The fact that the capacitor will only operate correctly on one waveband is a serious matter, however, and to get over this difficulty a technique is adopted which is equally applicable to normal capacitors, with identical sections, and to all wavebands.

The second and more flexible (and therefore more commonly used) method of getting one tuned circuit to "track" with another to give a constant frequency difference is to use a gang capacitor in which all the sections are identical, and to adjust the tuning characteristics of the oscillator section by suitable additional capacitors.

This technique is known variously as tracking or padding. Both words in this connection mean the same thing, namely, the adjustment of one tuned circuit relative to another to give a constant difference of frequency between the two.

Where a gang capacitor with specially shaped plates is used, the shaping is usually designed to give correct tracking on the medium waveband. For other bands, additional corrective capacitors have to be employed, in a manner now to be described.

As was seen in an earlier section, the ratio between the minimum frequency and the maximum frequency of the oscillator on each waveband is less than that of the signal frequency circuits, which means that the ratio between the minimum and maximum capacitance of the oscillator tuning capacitor must be lower than that of the other tuning capacitors.

Using a gang capacitor with identical sections, the capacitance ratio of the section used for oscillator tuning can be decreased either

by increasing the minimum capacitance of the section, or by decreasing the maximum capacitance.

The minimum can be slightly increased by connecting a small capacitor in parallel with the oscillator section of the gang, since capacitances in parallel are additive; the maximum can be slightly decreased by connecting a large capacitor in series with the oscillator section of the gang, since the capacitance of two capacitors in series is always less than that of either of the individual capacitors.

In practice a combination of the two methods is used. The adjustment of the small parallel capacitor at the higher frequency end of the scale (minimum capacitance) permits us to get the oscillator circuit tuning correct at this point, without seriously affecting the other end of the scale. At the lower frequency (maximum capacitance) end of the scale, the adjustment of the large series capacitor allows the oscillator circuit tuning to be corrected here, without appreciably affecting the higher frequency end of the scale.

Thus we now have two points on the scale, one at the top and one at the bottom, at which the signal frequency and oscillator circuits are correctly "tracked" relative to each other. The accuracy with which the circuits track over the rest of the scale now depends on careful choice of the value of the inductance of the tuning coil, the value of the parallel capacitor and the value of the series capacitor.

The method whereby the optimum values can be calculated will not be gone into here, but it may be said that by careful choice of the values, correct tracking may be secured at three points, with only very slight deviation, negligible in practice, at points between them.

So far only a single waveband has been considered. When two or more wavebands are covered by the receiver, it is quite impossible to choose values of parallel and series capacitors such that tracking will be correct on all wavebands.

If the capacitors are correct on the m.w. band, then on the l.w. band it will be necessary to use a larger parallel capacitor and a smaller series capacitor.

The basic oscillator tuning circuit is shown on the left of Fig. 20. Here L is the oscillator tuning coil, C_1 is the oscillator tuning

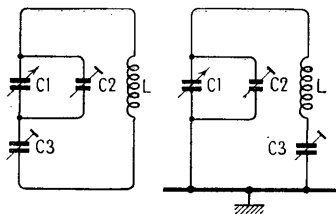

Fig. 20. Left, the basic oscillator tracking circuit; and right, a practical arrangement

capacitor (a section of the gang capacitor), C2 is the oscillator parallel trimmer, and C3 the oscillator series tracker. One possible practical arrangement is shown on the right of Fig. 20, where the components are similarly lettered; it is electrically identical with the basic circuit, and in each case C3 is effectively in series between C1 and L.

It is customary to refer to the parallel capacitor as the "oscillator trimmer", while the series capacitor is referred to as the "oscillator tracker", enabling the two to be distinguished. Sometimes fixed trackers or trimmers are used, either alone, or in conjunction with variable ones for adjustment purposes. Where variable (or rather adjustable) trimmer or tracker capacitors are used, they are not variable in the same sense as are those in the gang, which are adjusted by the user when he tunes his receiver. They are "pre-set" at the factory or workshop, where they are adjusted once and for all to the desired values. That is why they are shown by a slightly different symbol in diagrams.

Naturally, in a multi-band receiver switching has to be introduced to bring the appropriate trimmers and trackers into circuit on the various wavebands.

In modern receivers using iron-dust cored coils, it is often found that, whereas a parallel trimmer capacitor is used for adjustment at the higher-frequency end of the scale, tracking at the lower-frequency end of the scale is carried out by adjusting the coil core, and hence the inductance of the coil. In such cases a fixed series capacitor is usually employed in place of the usual pre-set one.

Short-wave oscillator coils often have provision for tracking at the low-frequency end of the scale by adjustment of a loop of wire or by displacement of the end turn of the coil winding to vary the inductance of the coil. Alternatively, they may be fitted with brass or aluminium cores, which have the opposite effect to iron-dust cores, causing a reduction of inductance when screwed into a coil, whereas an iron-dust core increases the inductance as it is screwed in.

As has already been explained, adjustment of the oscillator parallel trimmer is always carried out at the high-frequency (low-wavelength) end of the scale, usually at 1,400 kc/s (214 m) on m.w. and 300 kc/s (1,000 m) on l.w. The series tracking (or inductance adjustment) is carried out at the low-frequency (high-wavelength) end of the scale, usually at 600 kc/s (500 m) on m.w., and 150 kc/s (2,000 m) on l.w.

CHAPTER 11

I.F. AMPLIFIERS

The last section completed our consideration of the frequency-changer stage of a superhet, and we have arrived at the point where we have the intermediate frequency signal present in the anode circuit of the frequency-changer. As has already been seen, this signal must be amplified in the next stage of the set, namely, the i.f. amplifier. It was pointed out earlier that this stage in most superhets provides the bulk of the amplification, and also controls the selectivity of the receiver to a large degree. Furthermore, it is one of the stages to which the a.g.c. voltage of the receiver is applied.

The i.f. stage is tuned to the fixed intermediate frequency of the receiver, and its tuning is therefore not normally altered, except when re-alignment of the receiver is called for.

In most valved superhets the i.f. amplifier consists of a single stage using an r.f. pentode or tetrode valve of the variable-mu type. In a few cases two i.f. valves are employed, which arrangement has the advantage of providing extra amplification, besides permitting more satisfactory response curves to be obtained.

With a single stage, high gain is essential in order to secure the maximum overall amplification, and unless care is taken in the design a very slight fault may produce incipient or actual instability, with distortion and other troubles.

In the i.f. stage it is necessary to couple the anode circuit of the preceding frequency-changer to the grid circuit of the i.f. valve, and the anode circuit of the i.f. valve to the following stage, which is the second detector or demodulator. In practically all cases the coupling is by means of i.f. transformers having tuned primary and tuned secondary windings.

Fig. 21 shows the basic i.f. stage using a single valve and two tuned-primary, tuned-secondary air-cored transformers. Screen supply, bias arrangements and a.g.c. feed are omitted. The anode circuit of the frequency-changer valve is coupled by the first transformer C1, L1, L2, C2 to the grid circuit of the i.f. valve,

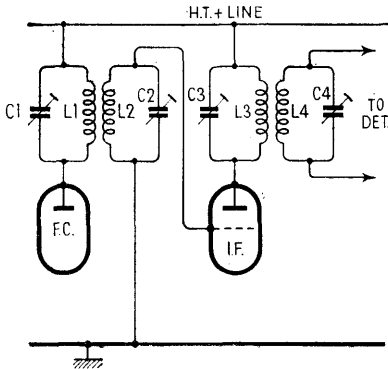

Fig. 21. Skeleton i.f. circuit showing the transformer couplings

while the anode circuit of this valve is coupled via the second transformer C3, L3, L4, C4 to the second detector stage of the receiver. All the capacitors are pre-set.

The circuit in more practical form is shown in Fig. 22. Here the valves and couplings are the same as in Fig. 21, but the additional components which go to make up the complete circuit have been added. R1 is the screen feed resistance, and C2 the screen decoupling capacitor. The suppressor is connected externally to the cathode of the valve, and the cathode is returned to chassis via R2 which forms a bias resistor for the i.f. valve. This fixes the minimum bias which the valve receives when the signal is so weak that the a.g.c. voltage is negligible.

If R2 were not present it would be possible for the bias under no signal conditions to fall to zero, which might cause instability in the stage. Usually the value of R2 is between 100 and 600 ohms, and the resistance is shunted by the capacitor C3, which generally has a value of about $0.1 \mu\text{F}$.

The a.g.c. bias in the case under consideration is series fed from the a.g.c. line, via R3 and the secondary of the first i.f. transformer, to the control grid of the i.f. valve. C1 is a decoupling capacitor (about $0.1 \mu\text{F}$) which places the bottom of the secondary of the first i.f. transformer at chassis (earth) potential as far as intermediate frequency voltages and currents are concerned. It is in place of the direct connection shown in Fig. 21. R3 is a decoupling resistance which may have a value between 250,000 ohms and 2 megohms, a value of 500,000 ohms being common. Sometimes, however, this resistance is omitted.

Turning now to the i.f. transformers themselves, these are designed in such a way that the desired response curve is obtained when

they are correctly adjusted. In their simplest form they consist of the two coils mounted on a former and spaced so that the desired degree of magnetic (or inductive) coupling between them is obtained. Each winding is tuned by a pre-set variable capacitor, adjustable by means of a screw or nut. The complete assembly is mounted in a screening can with holes in it giving it access to the trimmer capacitors.

Occasionally the tuning is carried out by fixed capacitors having very small pre-set types connected in parallel with them. In a few cases the i.f. transformers are tuned at the works with fixed capacitors only, and they are therefore not intended to be subsequently adjusted.

So far we have considered only air-cored i.f. transformers. The modern tendency, however, is to use iron-dust cored coils for greater efficiency and compactness. In this case the coils may have fixed cores, and be tuned with pre-set capacitors or, more commonly, they will have adjustable cores. The movement of the iron-dust core in or out of the coil by a screw adjustment gives a fine and smooth adjustment of the inductance of the coil. By shunting the coil with a fixed capacitor to form the tuned circuit, the adjustment of tuning may be carried out by means of the coil cores, and that is how it is commonly done in modern receivers.

This type of transformer usually has a high degree of stability of tuning, which is important in the case of fixed tuned circuits as employed in the i.f. stage of a receiver. The three types of transformer described are shown diagrammatically in Fig. 23.

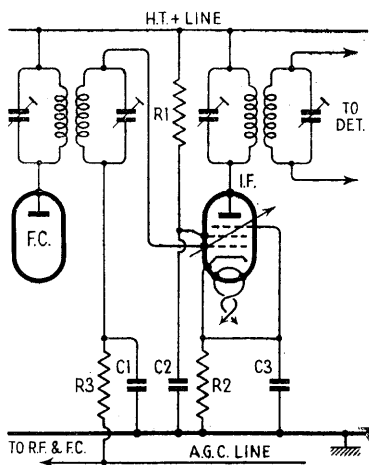

Fig. 22. Completed transformer-coupled i.f. stage

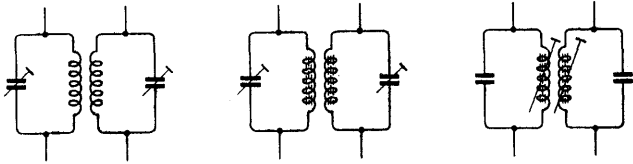

Fig. 23. Three types of i.f. transformer in diagrammatic form. Left, with air-cored coils and pre-set trimmer capacitors. Centre, with iron-dust cored coils and pre-set trimmer capacitors. Right, with coils having adjustable iron-dust cores and fixed trimmer capacitors

Here the presence of the iron-dust (or ferrite) coil cores is indicated by the fine broken lines which appear to be threading through the turns of the coils. Often these fine broken lines are drawn close beside the coil instead of actually through its turns, because this makes for a clearer drawing. The pre-set arrows then pass through the core, to show that it is the adjustable feature. Physically, of course, the core is inside the coil.

The first and second i.f. transformers in a receiver are not necessarily identical, and, in fact, for optimum results their design must be slightly different. It may be found that the two are wound with different types of wire to give different inductances and "goodness" factors. If the inductances are different, the values of the tuning capacitors will also have to be different, since the frequency of the tuned circuit must remain the same.

In some cases one or more of the windings may be of resistance wire to provide the degree of damping required by the designer. In other cases fixed resistors may be shunted across one or more of the windings to modify the response to the desired degree.

Again, it is quite common for a tapped secondary coil to be used to reduce the loading of the next part of the circuit on the secondary, or to prevent overloading of the next stage. In most cases, however, the i.f. transformers will be found to be simple 1 to 1 ratio components.

Although straightforward tuned transformers with fixed critical coupling between primary and secondary windings are the i.f. couplings used in the majority of receivers, the service technician or student will occasionally come across variants. For instance, an untuned choke coupling has been used in certain simple receivers, while infrequently in others a feed-back winding might be added, to act in the same way as the reaction coil in very early t.r.f. receivers.

Sometimes extra (capacitive) coupling between the two windings of a transformer is introduced in order to modify the response curve. This, if used, consists of a small fixed capacitor (a few micro-

microfarads) connected from the top (high potential) end of the primary to the top of the secondary, and it is usually called "top" coupling.

Occasionally the desired response of the i.f. coupling is secured by using a triple-tuned transformer, consisting of a tuned primary coupled to a tuned secondary, to which is coupled the third tuned winding, the tertiary. In this case the secondary has no external connection, except that one side of it is sometimes earthed. The arrangement is shown in Fig. 24.

Where transformers of the type so far discussed are used, they are designed to pass a given band of frequencies, usually a band about 9 kc/s wide and centred on the intermediate frequency of the receiver.

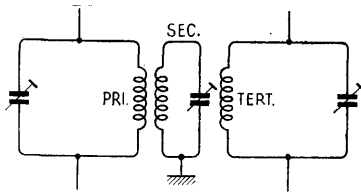

Fig. 24. Triple-tuned i.f. coupling. The three windings are mutually inductively coupled

For this reason they are called "band-pass" transformers, and the intention is that their overall response is "flat-topped", giving a level response at all frequencies within the pass-band, and "straight-sided", so that they reject frequencies just outside the pass-band. This ideal is not quite achieved, but a satisfactory approximation to it is obtained. The purpose of the triple-tuned transformer is to approach more closely to the ideal.

Whether the transformer is intended to possess a band-pass characteristic or not depends upon the designer, who achieves the effect he desires by adjusting the coupling between the tuned primary winding and the tuned secondary. There is a critical coupling condition in which the two windings react on each other when tuned to the same frequency, reducing the amplitude of the signal and spreading the breadth of their combined response curve.

When a transformer is designed with this critical degree of coupling, special precautions have to be taken during alignment to prevent the two windings from reacting on each other while the tuning adjustment is being made. This consists of connecting a "damping" resistance of about 25,000–50,000 ohms across one coil while the other one is being tuned, and then across the opposite coil while the second one is being tuned.

This "damping" process was a common feature of i.f. alignment in good class a.m. radio receivers at one time, because they were provided with band-pass tuning circuits, but it is not done in modern receivers at all. Its principal purpose was to obtain the best compromise in quality of reproduction, and to-day that can be better derived from an f.m. receiver. To-day i.f. transformer windings are coupled to less than the critical degree, and both primary and secondary can be "peaked", that is to say, each tuned for the maximum response at the intermediate frequency.

In earlier days, when band-pass tuning was regarded as necessary in good quality receivers, there was another method by which it could be achieved. This was to tune the windings of the i.f. transformers (usually there were two, as there are to-day, with a primary and secondary winding each) to different frequencies. Thus, in the case of an intermediate frequency of 465 kc/s, which was a common intermediate frequency then (the most common frequency to-day is 470 kc/s), the primary may be tuned to 463 kc/s and the secondary to 467 kc/s.

The effect of this, which is known as "staggered" tuning, is to provide a broader overall response in the i.f. tuning circuits, so that a wider band of frequencies is amplified and passed on, thus improving the quality of the reproduction. It is interesting to note that this form of tuning has been employed in television receivers, where an extremely large i.f. band-width is essential.

CHAPTER 12

VARIABLE SELECTIVITY

Other variants of the simple i.f. transformer couplings were at one time to be found in better-class receivers which incorporated arrangements for securing variable selectivity. Since the i.f. circuits largely control the selectivity of a superhet receiver, it is by adjustment of these circuits that variable selectivity can most readily be achieved. By altering the coupling between primary and secondary windings the response can be varied at will. A weak coupling gives a narrow response curve and, therefore, high selectivity; a tight coupling broadens the response and gives high fidelity.

Variable selectivity is not usually found in modern receivers for two principal reasons: firstly, because the frequency response is limited by the band-width of the channel frequency allocated to the particular transmitters, and cannot therefore exceed 4.5 kc/s; secondly, because, as a result of the allocation of a 9 kc/s channel for the particular transmission, there is normally no need to use a device to increase the selectivity by "sharpening" the tuning. Modern a.m. receivers all respond fairly well right up to 4.5 kc/s, and there would be no advantage in extending the frequency response beyond that limit. Thus the cost of variable selectivity is not justified.

The methods of altering the i.f. transformer coupling in order to vary the response differ from set to set, but in principle they come under two broad classifications.

First of all, there is the fairly obvious method of mechanically altering the relative positions of the primary and secondary coils. The closer they are together on the same axis, the tighter will be the inductive coupling. Consequently, if we arrange for one coil to be capable of movement along a guide towards the other, we shall obtain variable selectivity. This movement can be achieved by an arrangement of levers, or by a Bowden flexible wire, and usually a rotary knob control is fitted. Another mechanical arrangement is

to rotate one of the coils relative to the other, which is another way of varying the coupling between them. The usual method of indicating variable coupling of the mechanical type is shown in Fig. 25(a).

This mechanical method of securing variable selectivity enables a continuously variable adjustment to be made, so that any required combination of selectivity and fidelity can be achieved. In practice, however, such fine adjustments are rarely necessary.

The second method of securing variable selectivity is by altering the degree of coupling electrically, and usually this is done by switching. It is therefore not continuously variable; usually two or three selectivity positions are provided, which are chosen to give a useful compromise.

One example of this method is shown in Fig. 25(b). Here L1 is the primary coil, and L2 the secondary, while L3 is a small additional coupling coil for varying the selectivity, and S1, S2 are the switches. When S1 is closed, S2 is open, and the transformer is of the normal type. When S1 opens, however, S2 closes, and L3 is in series with L2, modifying the coupling between L1 and L2. Depending on the sense of the winding of L3, the selectivity may be increased or diminished when L3 is in circuit. Sometimes a resistance is also included in series with L3.

Another form of circuit for varying the coupling is shown in Fig. 25(c). Here L5 and L6 are the normal primary and secondary windings, tuned in the usual way. L4 and L7 are two small extra coils coupled to L5 and L6 respectively, and switched by S3 and S4. Capacitor C is across them. Here again two alternative selectivity positions are provided.

Other variable selectivity circuits have been used, and are all

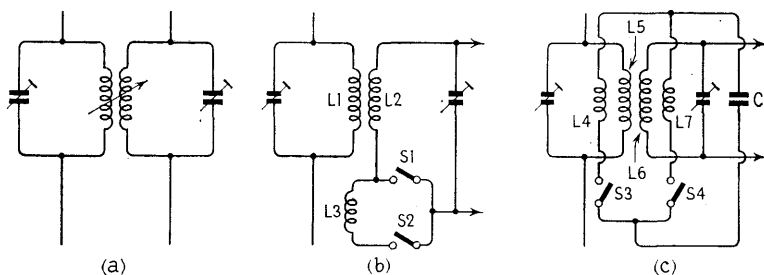

Fig. 25. Three examples of variable selectivity couplings in i.f. transformers, which was at one time common practice in better-class receivers. The arrow across the coils in (a) indicates that the coupling between them is varied mechanically by an external control knob

designed so that when changing from one position to the other there is no appreciable change in the frequency to which the i.f. transformer is tuned, which is naturally very important.

In most cases the variable selectivity arrangements are applied to one transformer only, usually the first; the second transformer is then of the normal type. It might be thought at first that, in passing a wide band signal from the first transformer to the more sharply tuned second one, the advantages of the first transformer would be lost, but this is not so, because the overall selectivity of the set depends on the characteristics of both transformers taken together, and a broadly tuned coupling in combination with one which is sharply tuned will always give a broader resultant signal than will two sharply tuned couplings.

When aligning a variable selectivity receiver it is usual to adjust the i.f. transformers when the set is switched for maximum selectivity.

CHAPTER 13

DEMODULATION CIRCUITS

We have now arrived at the point where the i.f. signal, amplified to the requisite degree, is present at the secondary of the final i.f. transformer.

It should be clear that this signal is in form very similar to the incoming signal picked up by the aerial, the main differences being that it is considerably greater in strength, and, as a result of the frequency-changing process, its carrier is at a lower frequency, equal to the intermediate frequency of the receiver.

In form, however, it still consists of a carrier signal amplitude modulated by audio frequencies which were impressed on the signal at the transmitter. Although the original signal has already undergone several changes in the early stages of the set, the audio-frequency modulation remains as it was, except for amplification and for any slight changes, such as a reduction of the very high modulation frequencies, caused by selective tuning in the stages through which it has passed.

When it leaves the i.f. stages of the receiver, therefore, the signal has to be demodulated, rectified, or "detected", just in the same way as the amplified signal in a "straight" receiver must be rectified before the a.f. content can be used.

The most common method of demodulation in a valved superheterodyne receiver is by the use of a diode valve, but early models used triodes, tetrodes or pentodes for this purpose, while a copper oxide or selenium rectifier has also been employed.

Skeleton circuits of early superheterodyne demodulators are shown in Fig. 26. At (a) is the cumulative grid detector, or "leaky grid" using a triode valve, although a tetrode or pentode was sometimes employed. This arrangement has the usual grid capacitor (about 0.0001 μF) and grid resistor (about 1 megohm). The cathode of the valve is generally returned to chassis. The a.f. modulation appears across a load in the anode circuit of the valve (shown by a square block), from which it is taken to the next stage.

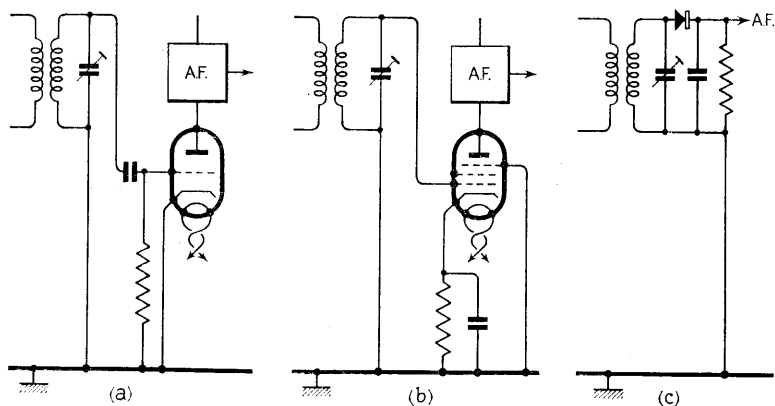

Fig. 26. Three examples of signal detector (or demodulator, or second detector) circuits that were used in early receivers

At Fig. 26(b) is shown an r.f. pentode, used as an anode bend type of detector, the valve being suitably biased by means of a cathode resistor (with by-pass capacitor). The screen-grid supply is omitted for clarity. Again the a.f. signal is available in the anode circuit of the valve. This type of detector is uncommon, and will rarely be encountered in radio receivers.

The Westector metal rectifier circuit, and the circuits of similar rectifier units or crystals, shown in skeleton form in Fig. 26(c), while not at all common, are actually a very close approach to the diode circuit which is now almost universal. This is understandable, for these rectifiers are actually diode valves, though not of the thermionic type. The circuit, it will be seen, is quite simple.

The rectifier is connected, in series with a resistor, across the last i.f. transformer secondary. The resistance forms the load across which the a.f. voltage is developed. Across it is a small fixed i.f. by-pass capacitor which shunts any residual i.f. signals to chassis. The value of the resistor is usually about 500,000 ohms, and that of the capacitor about $0.0001 \mu\text{F}$. From the high potential side of the load resistance the a.f. output can be taken and passed on to the next stage of the receiver.

It is now necessary to consider what may be termed the standard superheterodyne demodulator arrangement, using a thermionic diode. It should be pointed out that the rectifier diode is rarely found as a separate valve on its own. It usually forms part of a multiple valve, such as a double-diode, a double-diode-triode, a single-diode-pentode or a double-diode-pentode.

As we are only concerned at the moment with the signal diode section, the remainder of the multiple valve will be neglected for the present.

At (a) in Fig. 27 is shown the simplest diode demodulator circuit. One side of the final i.f. transformer secondary is connected to the diode anode, the diode cathode is returned to chassis, and the other side of the i.f. secondary goes, via the load resistance R1, to chassis. Across R1 is the by-pass capacitor C1, which acts as a reservoir. Reference to Fig. 26(c) will show the resemblance between the metal rectifier and the diode circuit; the transformer winding, the load resistance, and the valve (or metal rectifier) all being connected in series.

R1 and C1 usually have values of 500,000 ohms and 0.0001 μ F respectively, and the a.f. voltage is available across R1, being taken off from the junction of R1, C1 and the i.f. secondary.

Fig. 27(b) shows an arrangement in which the load resistance R2 is in the form of a potentiometer, from the slider of which the a.f. feed is taken. It is clear that with the slider at the top of R2 the circuit is the same as that of Fig. 27(a), but as the slider is moved down towards chassis the voltage tapped off from R2 progressively decreases, until with the slider at the bottom of R2 the voltage is zero. Thus the potentiometer acts not only as the load resistance, but also as a manual a.f. volume control. C2 is the usual i.f. by-pass capacitor.

Fig. 27(b) also shows a series resistance R3 in the a.f. feed, which is sometimes employed as an i.f. stopper, to prevent the residual

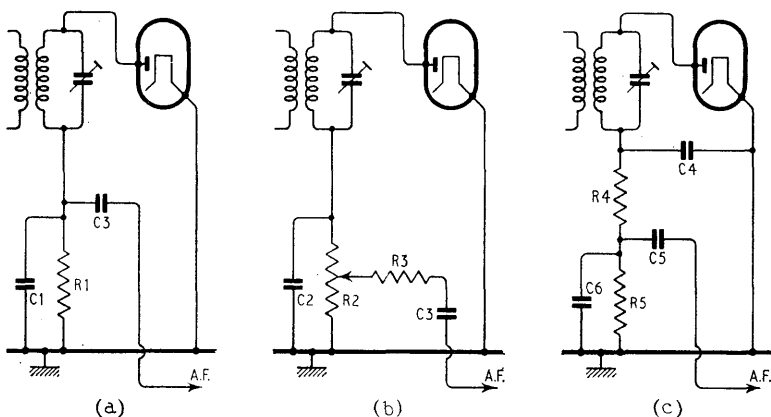

Fig. 27. Three variations of the diode detector circuit as it may be found in valved receivers. The diode usually forms part of a multiple valve

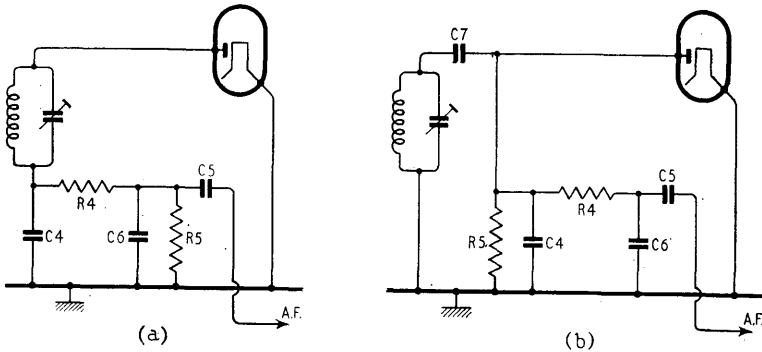

Fig. 28. Two further diode detector circuits. That at (a) is a rearrangement of Fig. 27(c) and is very commonly used in modern receivers. The circuit at (b) is parallel-fed

i.f. signal from reaching the a.f. section of the receiver. R3 usually has a value of about 100,000 ohms. C3 is the a.f. coupling capacitor, which was also shown in Fig. 27(a), and is nearly always used. The reason is that, in addition to the a.f. voltage present across the load resistance, there is also a d.c. voltage, resulting from rectification of the i.f. carrier, which must be blocked and thereby prevented from biasing the a.f. stage. The value of C3 is usually between 0.005 μF and 0.02 μF .

Incidentally, the rectified d.c. voltage mentioned above is sometimes used for automatic volume control purposes where a separate a.g.c. rectifier is not employed.

Finally, in Fig. 27(c) is shown a slightly more elaborate signal rectifier circuit. Here R5 is the load resistance with its i.f. by-pass capacitor C6. R4 and C4 are an i.f. stopper and the reservoir capacitor respectively. C5 is the a.f. coupling (and d.c. blocking) capacitor. Typical values are C4, C6, 0.0001 μF ; C5, 0.01 μF ; R4, 100,000 ohms; R5, 500,000 ohms.

The diagrams shown do not exhaust the possible signal rectifier arrangements, but they show the principle of the circuit. Alternative circuits usually have those of Fig. 27 as a basis, but sometimes more elaborate i.f. filter circuits are used, and slightly different connections may be employed. A very common arrangement in modern superhet receivers is shown in Fig. 28(a), where the components of Fig. 27(c) are simply rearranged to give a similar result.

A feature that is common in all the foregoing detector circuits is that their three main parts are connected in series each time, and from this fact they are all described as series-fed detector circuits.

In Fig. 28(b) is shown a parallel-fed, or shunt-fed, detector circuit which, although it is not very common, is still used occasionally in valved receivers. The signal is fed to the diode anode via C7, which is necessary only to prevent the i.f. transformer coil from short-circuiting R5 at audio frequencies and d.c. Fig. 28(b) shows another position for the i.f. filter resistance R4 which is alternative to the position shown in Fig. 28(a). R4 may be found in either position in either circuit. From the service technician's and student's points of view, the main thing is to locate the load resistance and a.f. coupling capacitor, which are the key components.

In most cases, automatic gain control will be employed, and as this is often interlinked with the demodulator circuit, it will be considered in the next section.

CHAPTER 14

A.G.C. PRINCIPLES

The automatic gain control circuit is employed in one form or another in practically every modern superhet, and is often associated with the demodulator. It seems opportune at the moment, therefore, to leave the continuation of the main circuit for a time, and to consider the automatic volume control arrangement, which really forms a kind of negative feed-back circuit.

Automatic volume control was introduced originally to counteract the effects of a fading input signal which previously involved more or less continuous operation of the manual volume control in order to keep the output volume fairly constant.

The automatic control achieves this by variation of the gain of one or more of the stages preceding the second detector, for which reason the system is described as "automatic gain control" (abbreviated to a.g.c.). In the early days of superhet receivers it was known as automatic volume control, or a.v.c.

The principle of operation of a simple a.g.c. circuit is not difficult to understand. It depends on the fact that the amplification of a variable- μ valve (and hence the gain of the stage in which the valve is used) is controlled by the value of its grid bias. As the negative bias of the valve is increased, the amplification factor falls in a smooth and regular manner.

Consequently, if it can be arranged that an increase in negative grid bias is produced by an increase in input signal strength, not only can matters be adjusted so that the gain of the stage is reduced to keep the signal output roughly constant, but at the same time the stage can be made capable of handling the increased input without overloading.

The method consists in feeding a suitable negative control bias to the early stages of the receiver, and now we have to consider how the control voltage is derived.

In order to provide effective control a negative voltage of up to 10V or 20V may be necessary and, of course, since it has to be used

for bias purposes, it must be a d.c. voltage. In order to obtain this voltage, it is usual to make use of the i.f. output of the receiver, rectify it, and feed back the rectified voltage to the grid circuits of the valves which are to be controlled.

The a.g.c. rectifier is invariably a diode, and it may be the same one as is used for the signal rectification, but more often a separate a.g.c. diode, which forms part of a double-diode valve, a double-diode-triode or a double-diode-pentode valve, is used.

The simplest possible a.g.c. circuit is shown in Fig. 29. A diode valve is used as the rectifier, and R1 is the diode load resistance. The signal is applied to the diode circuit from the secondary of the last i.f. transformer, and is rectified, as it was in Figs. 27 and 28.

The rectified carrier, which represents the d.c. component, and on which are superimposed a.f. currents due to the modulation, flows through R1, and therefore produces a voltage drop across it. At the point A the voltage will be negative relative to the cathode of the diode, which is at earth potential. This is because in the conducting state of the diode negative electrons flow from cathode to anode, and leak away via the secondary of the i.f. transformer and R1 back to the cathode.

Consequently, at point A we have a d.c. voltage proportional to the mean value of the signal carrier, together with a.f. voltages due to the modulation. If we apply this d.c. voltage as bias to the grid circuits of the valves to be controlled, it is clear that as the signal amplitude at the diode rises, the negative bias will increase, and this will reduce the amplification of the variable- μ valves, and hence the sensitivity of the stages in which they are situated.

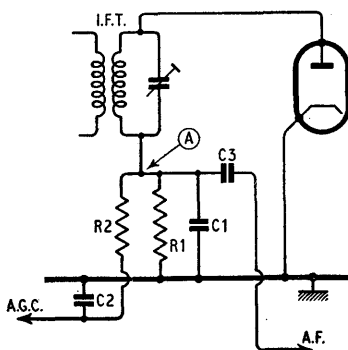

Fig. 29. The simplest a.g.c. circuit, using the same diode for signal detection and a.g.c. rectification

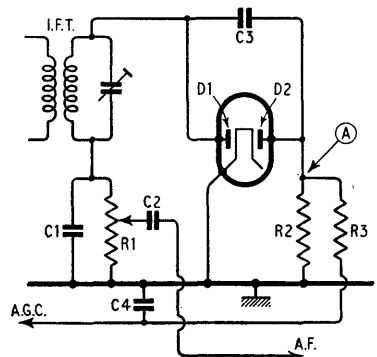

Fig. 30. A simple circuit using one diode for signal rectification and another for the a.g.c. potential

This, in turn, will lower the signal at the diode, and the control bias will be reduced until a balance occurs. In theory, therefore, whatever the value of the input signal, the output will remain constant. In practice, this is not perfectly true, and there are several difficulties to be overcome, as will be seen later.

It will be noted that Fig. 29 is the same as Fig. 27(a), but with the addition of R2, in series with the a.g.c. line, and C2 from the a.g.c. line to chassis. These components are used to block and by-pass r.f. and i.f. voltages to earth, and to smooth out the irregularities caused by the a.f. variations on the d.c. control voltage. If R2 and C2 were not present, r.f. and i.f. voltages might be fed back to the early stages and cause instability.

At the point A, of course, the a.f. modulation is still present, and is taken to the a.f. stages of the receiver, capacitor C3 being used to block the passage of d.c. from point A which would otherwise apply bias to the control grid of the next valve. In this circuit, therefore, the single diode acts as a demodulator and a.g.c. rectifier.

Fig. 30 shows another simple a.g.c. circuit in which a double-diode valve is used. Here diode D1 is used solely for signal rectification, the diode load resistance R1 also acting as a.f. volume control. C1 is a by-pass capacitor (of low value) and C2 the usual coupling capacitor to the a.f. stages. C3, usually of a low value (about 50 pF) feeds a part of the signal at the secondary of the last i.f. transformer to the second diode (D2), which is provided with its own load resistance R2.

It will be quickly recognized that we have in the circuit of D1 a series-type detector circuit, while in that of D2 we have a parallel-fed shunt circuit of the type shown in Fig. 28(b). The latter, although it rectifies the signal, is not referred to as a detector.

As before, a negative voltage with respect to earth is present at A as soon as a signal reaches D2, and is tapped off and passed via the filter resistance R3 to the grid circuits of the valves to be controlled. C4 is a by-pass capacitor, removing any residual r.f. and i.f. signals, and it can have a large value (say $0.1 \mu\text{F}$) in order to smooth the d.c. voltage (on which, of course, the a.f. modulation is impressed).

CHAPTER 15

DELAYED A.G.C.

The foregoing circuits, although workable, are not often used in practice, because simple a.g.c. as described has certain disadvantages. However, examples of them will be found in some all-dry battery superhets using a single-diode-triode valve in this stage of the receiver.

The main difficulty with the simple circuits is that any signal, however small, will necessarily produce a control voltage, and will therefore be further reduced. It is obvious that a receiver which reduces the strength of signals which initially are too small to load the output valve will not be satisfactory.

What is needed therefore is some arrangement whereby all signals below a certain strength are not affected by the a.g.c. circuits, but that above some predetermined signal strength the a.g.c. comes into action.

This achieved by what is known as "delayed" a.g.c., and this type of circuit is the one most commonly used. It is very similar to the simple a.g.c. already described, but with the addition of a means of rendering the action inoperative below a certain signal voltage.

Suppose we need a voltage of, say, 4V peak at the second detector before the output stage is reasonably loaded. Then, obviously, signals which do not reach this peak value need the full amplification available in the early stages, while stronger signals need a.g.c.

It is therefore necessary to arrange that for peak voltages below 4V which reach the second detector the a.g.c. diode must be prevented from rectifying and so producing a negative control voltage.

One way of doing this would be to apply a negative voltage of 4V to the a.g.c. diode anode by means of a suitable bias battery. When this is done, any signal below 4V peak will not make the diode anode positive enough to conduct, even on its positive half-cycles, and consequently no diode current will flow, and there will therefore

be no voltage drop across the load resistance, and no control voltage will be produced.

Above 4V, however, the signal will overcome the applied delay voltage on its positive half-cycles, and an a.g.c. voltage will be produced—but naturally a lower one than if the delay voltage had not been present. By suitable choice of circuits and values, this fact need not be a disadvantage.

Instead of applying a negative delay voltage to the diode anode of the a.g.c. rectifier, we can achieve the same results by applying a similar *positive* voltage (relative to earth) to the cathode of the diode. Fig. 31 shows a double diode circuit in which this has been done, and it should be compared with Fig. 30.

It will be seen that to obtain in a convenient way a positive voltage on the cathode of the double diode, relative to earth, the cathode is taken to the cathode of the following valve, which is positive to earth by virtue of its cathode bias resistance R4.

In this case the delay voltage is the same as the bias voltage of the succeeding valve, and this is often satisfactory.

If a lower voltage is needed, however, R4 can consist of two resistors in series, with the diode cathode taken to their junction. By suitable choice of values, any delay voltage up to the total bias voltage of the succeeding valve can be obtained.

It will be noted that the a.g.c. diode load remains connected to the earth line, so that this diode anode is *negative* relative to its

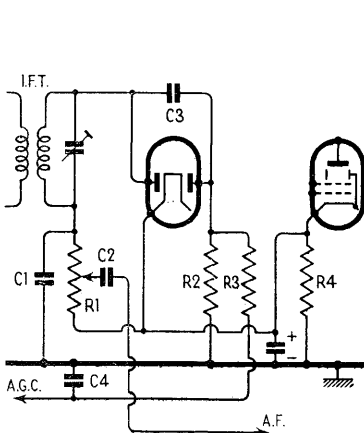

Fig. 31. One method of introducing delay in an a.g.c. circuit is to use the cathode voltage of the following valve to bias the a.g.c. diode

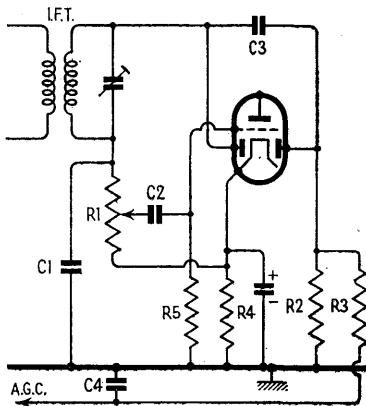

Fig. 32. When a double-diode-triode valve is used, a.g.c. delay potential can be obtained from the cathode voltage of the same valve without applying bias to the detector diode

cathode by the delay voltage. As we do not wish the signal diode to be delayed, its load resistance R1 must be returned to the cathode of the double diode, and not to earth as in Fig. 30.

Fig. 32 shows the delayed a.g.c. circuit of the popular double-diode-triode. Here the triode section of the valve is used as the first a.f. amplifier of the receiver. Most of the components are as in Fig. 31. The a.f. voltage is passed to the triode grid via C2, and R5 is the usual grid resistance. R4 is the bias resistance for the triode section of the valve, and provides the requisite delay voltage for the a.g.c. diode, the load resistance R2 being returned to the earth line. The load resistance R1 of the signal diode, however, is returned to the cathode of the valve to avoid imposing a delay on this diode.

These are only a few of the possible arrangements, some of which are exceedingly complex. Sometimes the a.g.c. diode load resistance is tapped, so that only part of the available voltage is used for control purposes; sometimes the full control is applied to the frequency-changer, and only a part to the i.f. valve, or vice versa.

Much depends on the characteristics of the valves used, and the available gain in the early part of the receiver, and no hard and fast rules can be laid down.

It is fairly common practice to feed the a.g.c. diode, not from the secondary of the final i.f. transformer, but from the anode of the i.f. valve, via the usual small coupling capacitor. This has certain advantages, including the removal of part of the damping from the secondary of the transformer. The various filter and bypass arrangements used also differ widely; some sets use the minimum of components for this purpose; others employ elaborate arrangements.

Care has to be taken in the design of a.g.c. circuits to avoid the introduction of distortion which may arise if the various circuits are not correctly proportioned.

Amplified a.g.c. has a number of advantages, but its complication is seldom worth while in the average receiver, as it often involves the use of an extra valve. Sometimes it has been achieved by applying the a.g.c. bias to the a.f. amplifier, when it is called post-detection a.g.c. By the use of amplified a.g.c. it is possible not only to increase the bias sufficiently to keep the output constant, but to over-bias the receiver, so that the output actually falls with increased signal strength. Such over-correction, of course, is not desirable.

Quiet a.g.c. was introduced in early receivers to avoid the heavy background noise which occurs as one tunes between two stations

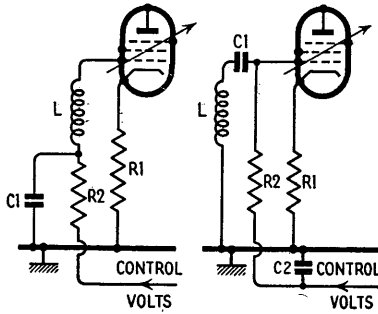

Fig. 33. Two methods of applying the control voltage to the grid circuit of a controlled valve

and the gain of the set rises to maximum. It functions by rendering the signal diode inoperative until a signal of acceptable strength is applied, so that between stations the set is silent.

Turning to the controlled valves, the arrangements there have already been touched upon earlier, but they will be repeated here for convenience. Fig. 33 shows two arrangements for applying the control voltage. In each case L is part of the tuned circuit preceding the valve, and R1 is a fixed bias resistance which assures that the valve receives its correct minimum bias, even when no negative control voltage is present.

In each case also the control voltage is fed to the grid via R2 either through the coil L or, if as in the right-hand diagram, there is no d.c. connection from L to the grid, R2 is connected to the grid. C1, in the left-hand diagram, places the bottom of L at chassis potential as far as r.f. is concerned, while in the right-hand diagram C1 is the existing grid capacitor, and the bottom of L is connected directly to chassis. C2 is then used as an r.f. and i.f. by-pass, decoupling the grid circuit. In the left-hand diagram decoupling is performed by C1 and R2.

CHAPTER 16

A.G.C. CIRCUIT VARIATIONS AND A NOTE ON A.F.C.

The previous chapter, dealing with the most common forms of delayed automatic volume control, gave sufficient information to enable this part of the circuit to be understood and traced out in a complete circuit diagram.

It will be gathered from a study of a number of complete circuit diagrams that, although the principles already described have usually been followed, slight variations are introduced by some designers. One of these variations is in the particular valves which are controlled, and another is in the amount of control applied to each. In practically all cases the full available control voltage is applied to the frequency-changer valve, the mixer section of which is, of course, of the variable- μ type. The only exception to this is that in many cases no a.g.c. is applied to this valve on the short-wave band or bands. As a general rule frequency-changers operate best on short waves with fixed bias, and in this case an examination of the circuit will show that the grid return (usually the bottom of the tuned input circuit) on the s.w. band is connected not to the a.g.c. line, but to chassis. A.G.C. is then still applied as usual to the i.f. stages, however.

Where an r.f. stage is used prior to the frequency-changer, a.g.c. will be applied to the r.f. stage and to the frequency-changer. In this case it is often preferable to operate the i.f. stage with fixed bias, for the efficiency of the a.g.c. action is not seriously reduced, and the possibility of the i.f. stage introducing harmonic distortion is reduced.

Alternatively, the i.f. valve can be supplied with a fraction of the total available control voltage, and this is often found also in receivers which have no r.f. stage. Such an arrangement is achieved by replacing the single a.g.c. diode load resistance by two resistances in series, forming a potential divider. The total resistances of the

divider will be the same as that of the single resistor normally used.

The total control voltage available is taken from the diode end of the load potential divider as usual. The lower voltage is taken from the junction of the two resistors forming the divider. Obviously, any fraction of the total voltage available can be obtained from this point by suitably choosing the relative values of the two resistances. Very often they are equal, giving half the total voltage at the tapping, but the ratio may be as high as five to one in certain receivers.

Occasionally three resistors in series are used as the a.g.c. diode load to provide the total a.g.c. voltage and two lower values. For instance, the r.f. stage may receive the maximum a.g.c. voltage, the frequency-changer three-quarters of the maximum, and the i.f. stage half the maximum.

Each additional tapping increases the number of components necessary, for each feed circuit usually needs a series filter resistor and a by-pass capacitor.

When two i.f. stages are used in the receiver, which is very rare, it is usually, but not invariably, the practice to operate the second i.f. valve at fixed bias.

The time-constant of the feed circuit, that is, the time taken for the capacitors in the circuit to charge up to a certain fraction of the feed voltage (or to discharge to a certain fraction of the initial voltage), is a point which has to be borne in mind by the designer of the circuit if unpleasant effects are to be avoided. The time-constant controls the speed at which changes in the a.g.c. potential act on the controlled valves.

If this speed is too great, distortion or reduction in the bass response of the set may occur; too slow a time-constant will not allow the a.g.c. circuit to follow rapid changes in input signal, such as fast fades on the short waves.

The charging time-constant in the case of a simple circuit is proportional to the product of the value of the series feed resistance and by-pass capacitor, but for circuits with several feeds and filters it is much more complicated. Obviously, however, increasing the value of either the filter resistances or capacitors will increase the time-constant, and vice-versa.

There is always a temptation when repairing a receiver to replace a component which is apparently unimportant by one of a different value if the correct one is not immediately available. In the case of a.g.c. filter components serious changes in value should be avoided on account of the change in time-constant which they will introduce.

It will also be readily understood from this that any major changes in the values of these components (which is particularly likely in the case of resistors, through aging) may give rise to faults which would normally be difficult to trace to their origin.

Whereas in the case of indirectly heated valves the delay voltage for the a.g.c. rectifier is usually obtained by making the cathode of the diode valve positive relative to chassis by the required amount (as described in the last chapter), in the case of directly heated battery valves this method cannot be used. It is customary in this case to take the bottom of the a.g.c. diode load resistance to some point which is *negative* relative to chassis, and thus the diode anode is made negative to chassis, which, as was seen in the last chapter, is the same as making the cathode positive to chassis.

The necessary negative delay voltage (together with other bias voltages needed in the receiver) can be obtained in two ways. One is by the use of a grid bias battery, one cell of which is used to give 1.5V delay by connecting the a.g.c. load resistance to it.

In other cases part of the grid bias battery has connected across it a number of resistors in series, in the form of a potentiometer, the resistors being chosen to provide the desired delay voltage (and other bias voltages) at the tapping points.

A more common method is to employ automatic bias, which eliminates the need for a grid bias battery. In this case, instead of connecting the negative end of the h.t. battery to l.t. negative (and chassis), it is connected to one end of a chain of resistors in series, the other end of this chain going to chassis and l.t. negative. Since the total h.t. current of the receiver flows through the resistors, a voltage is developed across them, and the tappings at the junctions of the resistors provide fractions of the total voltage available across the whole potential divider. Often only two resistors are used, the a.g.c. load resistance being taken to their junction.

Examples of this arrangement are seen in many battery superhet circuits. Often an electrolytic by-pass capacitor is shunted across the potential divider from h.t. negative to l.t. negative, in which case it should be noted that the *positive* connection of this capacitor goes to l.t. negative (and chassis).

Certain battery receivers used to employ a special indirectly-heated double-diode battery valve for demodulation and a.g.c. In this case some manufacturers returned the a.g.c. load resistance to a negative point relative to chassis, others returned this resistance to chassis, and connected the cathode of the valve to a point positive relative to chassis, while others used a combination of the two methods, the voltages so obtained being additive.

AUTOMATIC FREQUENCY CORRECTION

A.G.C. is a form of negative feedback that lowers the gain of an amplifier in proportion to an increase in signal strength. Automatic frequency correction, which is usually abbreviated to a.f.c., is also a form of feedback, but from its purpose it could more justly be described as positive rather than negative. Like a.g.c. it measures the conditions at the output end of an i.f. amplifier and feeds back a correcting signal to the input of that amplifier.

With a.f.c., however, it is the tuning that is corrected, if the receiver is not properly tuned to the station it is receiving. The correction signal is obtained by applying the output from the i.f. amplifier to a double diode rectifying circuit, but this pair is fed from separate i.f. transformer, quite distinct from the one that feeds the detector. The circuit of this transformer is rather special, and its secondary winding receives its signal from two sources: from the primary in the normal manner; and from another source, either a capacitor coupling it to the i.f. valve anode, or from a third winding on the transformer. Such a circuit is called a "discriminator".

How all this is done is explained in the Appendix at the end of this book, but the result is that if the intermediate frequency of the signal being received is not exactly in tune with the fixed intermediate frequency of the i.f. amplifier, the rectified outputs from the two diodes differ, whereas when the i.f. is correct they balance exactly. The reader will by now understand that the correct intermediate frequency is obtained by tuning the oscillator so that the difference between its frequency and that of the incoming signal is exactly the same as the i.f. of the set. If it is not, then the set is mistuned, and a mistuned signal passes through the i.f. amplifier. This can be corrected by a small adjustment of the oscillator tuning control, changing the oscillator frequency to the correct value.

The purpose of a.f.c. is to perform this adjustment automatically, and it is achieved by connecting a valve called a "reactance valve" across the tuning circuit of the oscillator. As its name implies, the valve acts as a reactance, in this case a capacitive reactance, and it has the same effect on the oscillator circuit as a capacitor. Whereas the value of a variable capacitor can be adjusted by moving its vanes, the capacitive effect of a reactance valve can be varied by means of adjusting its grid bias.

So the output voltage from the discriminator is applied to the reactance valve as bias, and the circuit is so arranged (assuming that the oscillator frequency is higher than the signal frequency) that if the beat frequency from the incoming signal is higher than the

i.f. of the receiver, the bias becomes more positive. This increases the effective capacitance of the reactance valve, lowering the frequency at which the oscillator is working until it produces a "beat" which is of the same frequency as the i.f. of the set. If the incoming frequency is *lower* than the i.f. of the set, bias becomes more *negative* and corrects the frequency in the opposite direction.

Usually, but not always, the oscillator works at a higher frequency than the signal it is receiving, but that does not affect the principle. The output from the discriminator is arranged to be positive at one end of its load and negative at the other, and it can be connected either way round when it is applied to the reactance valve. If the oscillator works at a lower frequency than the signal the correction required is in the opposite direction, and this can be achieved simply by reversing the polarity of the discriminator output as it is applied to the reactance valve.

CHAPTER 17

A.F. AMPLIFICATION

Following the demodulator stage (and returning once more to the main circuit of the receiver), we come to the section which provides audio frequency amplification, but before considering the a.f. amplifier stage or stages in detail, it is important to realize what the amplifier has to do. To return to the demodulator (signal detector) stage for a moment, it will be remembered that the function of this stage is to extract and make available for further amplification the a.f. modulation of the amplified i.f. signal. At the demodulator we have the a.f. voltage developed across a load in the anode circuit of the valve, or, in other receivers, across the signal diode load resistance, and as was shown in the diagrams in Figs. 27 and 28, this voltage is tapped off and passed to the a.f. stages of the receiver.

It must be pointed out here that the a.f. output obtainable from the demodulator is quite inadequate to operate a loudspeaker. For this purpose the power required is considerably greater than could be drawn from the receiver at this stage. Voltage in itself is useless for this purpose, and in the a.f. stages of the receiver, although the voltage obtained from the demodulator may be amplified, one of the main functions of these stages is to provide a.f. *power*. At the demodulator, the power available is of the order of a milliwatt or less, whilst the loudspeaker requires anything from 100 mW to 5 W (5,000 mW) or possibly even more. Consequently, the a.f. amplifier must provide a high degree of power amplification.

This may be obtained in several ways, depending on the types of valves used. For instance, there may first be one stage of voltage amplification, followed by a stage of power amplification in which one or more output valves are used; at the other end of the scale, using a high-efficiency power output pentode or tetrode, the output from the demodulator may be fed, via a suitable coupling, direct to the output valve, without any intermediate stage of amplification.

Whatever arrangement is used, the first step is to feed the a.f. signal from the demodulator to the grid of the following valve,

whether this is a voltage amplifier or the output power valve. For this purpose it is necessary that some form of a.f. coupling be used, and the two usual basic forms are resistance-capacitance and transformer coupling. These basic forms are sometimes modified, as will be seen later. Fig. 34(a) shows the basic form of resistance-capacitance coupling, which is almost invariably used for coupling the demodulator to the next stage.

R1 represents the demodulator load resistance (which will be in the anode circuit of a triode, tetrode or pentode used in early superhets, or will be the signal diode load resistance in sets using diode demodulation, like R1 in Fig. 27(a)). Between the high a.f. potential end of R1 (the anode end in the case of triodes, etc., and the end remote from chassis in the case of diodes) and the grid of the following valve is the fixed capacitor C1 which permits the a.f. voltages to pass, but isolates the succeeding part of the circuit as far as d.c. is concerned. R2 is the grid resistor of the succeeding valve across which the a.f. input voltage to this valve is developed, and via which grid bias is applied to the valve. R3 is the usual cathode bias resistance, by-passed by the capacitor C3.

This resistance, of course, makes the cathode of the valve positive to chassis, and since the grid is returned to chassis via R2, the cathode is equally positive to grid, or, in other words, the grid is negative to cathode, which is the same thing.

The values of R1, C1, R2, and R3, while not critical, have to be carefully chosen by the designer, and should not be subsequently varied appreciably. The value chosen for R1 may vary between wide limits according to the valve within which it is used. C1 may be between 0.001 μF and 0.1 μF , but is not usually greater than 0.01 μF where it is used to couple the demodulator circuit to the next stage. R2 usually has a value of from 250,000 ohms to 5 megohms, high when the valve impedance is high and C1 is low. The value of R3 depends on the valve in use, while C3 has a value of 25 μF or 50 μF , and is of the low voltage electrolytic type.

In a.f. amplifiers resistance-capacitance coupling is used almost exclusively, and with it valves of very high impedance are used. As the impedance of the valve rises, so does that of suitable coupling components, so that a modern high impedance triode a.f. amplifier might have a coupling capacitor of 0.001 μF or 0.002 μF , a grid resistance as high as 10 megohms (a very common value) and an anode resistance of about one quarter of a megohm. If a pentode is employed, the respective values might well be 0.002 μF , 10 megohms and 1 megohm, while the screen feed resistor might have a value of 3 megohms.

Fig. 34. The basic a.f. amplifier stage: (a) resistance-capacitance coupled; (b) transformer coupled

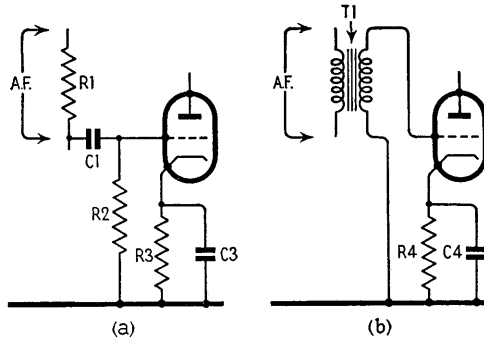

A peculiarity of these circuits is that the triode appears from the circuit diagram to be unbiased. The 10 megohm grid resistor is connected directly to chassis, and so is the cathode of the valve, with no obvious source of bias. These are high-gain circuits, however, and they handle only very small signals, so that a small bias voltage only is required, and that is obtained from an extremely small grid current that flows through the 10 megohm resistance. The current is less than one micro-amp (one-millionth of an ampere), and it results from what is termed the "contact potential" at the grid of the valve. The electrons flow through the resistance from grid back to cathode, so the grid end of the resistance is negative.

Turning now to the transformer-coupled a.f. stage, this is represented basically in Fig. 34(b). Here T1 is an iron-cored a.f. transformer, with a step-up voltage ratio of about 1 to 3 between primary and secondary windings. The primary acts as the load impedance across which the a.f. voltage to be amplified is developed. A higher voltage is developed across the secondary of transformer T1 and applied between the grid of the following valve and chassis. This valve has the bias resistor R4 in its cathode circuit, by-passed by C4. Bias is applied to the grid of the valve via the secondary winding of the transformer, and since there is no d.c. connection between primary and secondary, the input and output circuits are isolated as far as d.c. is concerned.

Various considerations of design make it impossible to use transformer coupling of this kind in certain parts of the circuit, such as between a diode demodulator and the succeeding stage, for example, but in early receivers it was often used to couple one a.f. stage to the next, particularly in cases where the step-up of voltage between the primary and secondary windings (not obtained with resistance coupling) could be utilized to advantage.

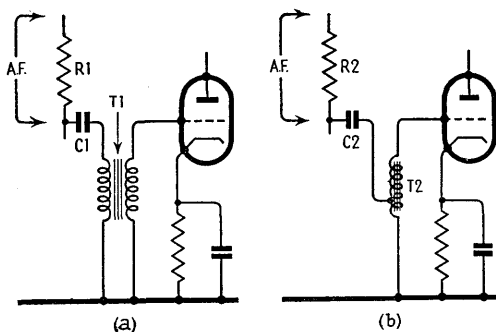

Fig. 35. At (a) is the resistance-coupled transformer stage, while at (b) the double-wound transformer is replaced by an auto-transformer, which might be regarded as a tapped choke

In place of pure transformer coupling, it was at one time quite common to use parallel-fed transformer coupling. This is shown in Fig. 35(a), where the primary of the transformer T1 is fed from the high a.f. potential end of a load resistance R1 via the coupling capacitor C1. The secondary of T1 is connected between the grid of the following valve and chassis as before. Comparison of this circuit with those of Figs. 34(a) and 34(b) shows that parallel-fed transformer coupling is really a combination of resistance and transformer coupling. One advantage of it is that the transformer primary carries no d.c., as it does in Fig. 34(b), where it primary is usually in series with the preceding valve anode circuit.

There is therefore no risk of saturation of the core and consequent distortion; in fact, the transformer can be designed to give an excellent response at considerably less cost than would be the case in a normal transformer-coupled stage. It has the advantage that the step-up of voltage introduced by a transformer is retained. Owing to the absence of d.c. current in the primary, it is possible to design a.f. transformers of less bulk than one cubic inch, using mumetal stampings for the core.

Another variation of straightforward transformer coupling is shown in Fig. 35(b). This is known as auto-transformer coupling, T2 being an auto-transformer, with a single winding which is tapped to give a step-up ratio between input and output. Actually, although called a transformer, T2 is really a tapped iron-cored choke. It is parallel-fed by R2 and C2, the "primary" being the section of T2 between the tapping and chassis, and the "secondary" the whole winding, connected in the grid circuit of the following valve.

A modification of resistance-capacitance coupling has sometimes been used in which the load resistance R1 in Fig. 34(a) is replaced by an iron-cored choke. This is known as choke-capacitance coupling, but it was never very common in ordinary receivers.

CHAPTER 18

PRACTICAL A.F. CIRCUITS

Taking first of all the stage following the demodulator, it can be said that in the case of old superhets where the demodulator was a triode, tetrode or pentode valve, the circuit of Fig. 34(a) is correct if R1 is connected in series with the anode circuit of the demodulator valve.

In the case of superhets with diode demodulators, a typical circuit is shown in Fig. 36(a). Here the first valve is the diode detector and the second the first a.f. amplifier, which is a separate triode. I.F. stopper resistors and by-pass capacitors are not shown for reasons of clarity, and the a.g.c. arrangements are also omitted. R1 is the signal diode load resistance, and C1, taken from the high a.f. potential end of R1, is the a.f. coupling capacitor.

At this point it is customary, in practically all modern superhets which have only one a.f. stage, for volume control arrangements to be introduced. This is usually achieved by means of a variable potentiometer connected so as to pass anything from zero to the full available a.f. voltage to the grid of the a.f. valve. In Fig. 36(a), R2 is the volume control potentiometer, with one end connected to chassis. The other end is connected to C1, so that across R2 the whole of the a.f. voltage passed on from the demodulator stage is developed. The variable contact, or slider, of R2 is connected to the grid of the a.f. valve.

It will be seen that the portion of R2 included between the slider and chassis becomes the grid resistor of the a.f. valve, and provides the necessary grid return to chassis, enabling the bias voltage developed across R3 to be applied to the valve. The minimum volume will be obtained with the slider of R2 near the chassis end of this component, the maximum being obtained when the slider is moved to the end of R2 which is connected to C1.

It has been found that human appreciation of the loudness of sound follows a logarithmic law, so that sound volume must be increased four times to give the impression that it is twice as loud.

In order to obtain an apparently equal increase in output volume for a given change in the setting of the volume control knob at any position of its rotation, therefore, volume control potentiometers usually have a logarithmically graded resistance element, and they are then said to have a "log law".

Since in an a.f. voltage amplifier which is correctly operated there will be negligible grid current flowing, R2 does not have to carry any appreciable direct current, and the speech current flowing through it is very small, so that its power dissipation is negligible. Only when the grid resistance is something like 5 to 10 megohms does grid current have a significant effect. Consequently types employing carbon tracks can be employed with success, and wire-wound types are not necessary. This is all the more important because the resistance value of R2 in the position shown may be 1 or 2 megohms. The connection between the two cathodes is necessary only to provide a.g.c. delay voltage, as was explained in the section dealing with delayed a.g.c. Otherwise the cathode of the diode valve could just as well be connected to chassis.

Fig. 36(b) shows how little the circuit of Fig. 36(a) is altered when a double-diode-triode valve is used in place of the separate diode and triode valves. A comparison will show that, apart from the omission of the connection between the two cathodes in Fig. 36(a) (which is virtually present because the single cathode of the double-diode-triode serves both the diode and the triode sections), there is no electrical difference between the two circuits. R4 corresponds to R1, R5 to R2, R6 to R3 and C2 to C1, and their values are the same in each case, providing that the multiple valve has the same characteristics as those of the two separate valves.

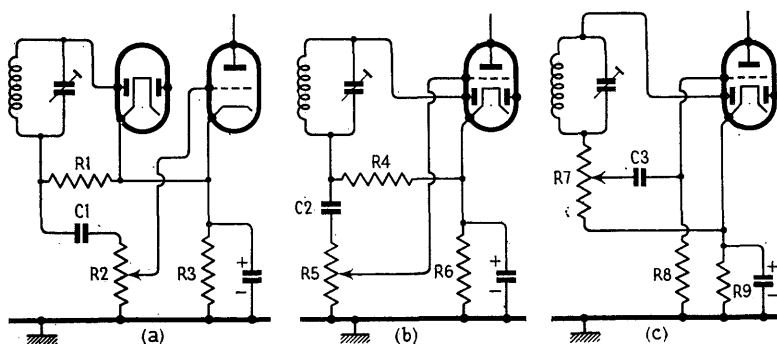
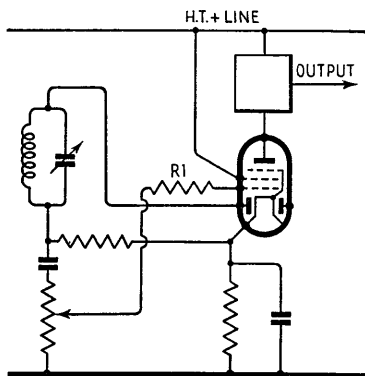

Fig. 36. Three examples of a.f. coupling between a diode detector and an a.f. amplifier

Fig. 36(c) shows a circuit somewhat similar to Fig. 36(b), except that a re-arrangement has been made. It will be noted that the potentiometer volume control R7 now acts as the signal diode load resistance in place of R4, the ends of the element being connected between the bottom of the secondary of the last i.f. transformer and the cathode of the valve. The slider of R7 is taken via the usual a.f.

Fig. 37. An example of direct coupling from diode to output pentode, using a high-efficiency double-diode-pentode output valve



coupling capacitor C3 to the grid of the triode section, while R8 is the grid resistance, in place of R5. R9 is the usual bias resistor.

The difference between Fig. 36(b) and Fig. 36(c), therefore, is that R7 and R8 are interchanged, relative to R4 and R5. Both circuits are commonly encountered. It should be pointed out that the value of the grid resistor in an a.f. amplifier is usually several times that of the preceding load resistor. Consequently, R5 has a higher value than R4, and R8 has a higher value than R7. Thus R5 may be 2 megohms and R4 500,000 ohms, whilst R8 may be 2 megohms and R7 500,000 ohms.

It was mentioned earlier that in certain cases where a high efficiency output valve is employed one can couple the output from the demodulator stage directly to the grid of the output stage, and so obviate the need for an intermediate stage of a.f. voltage amplification. A typical circuit, omitting minor details, is Fig. 37 where the valve is a double-diode-output pentode.

As will be seen, except for the valve the circuit is almost identical to that of Fig. 36(b). In the anode circuit of the valve is the load impedance in which the a.f. power is developed. This load is usually the output transformer coupling the valve to the loudspeaker.

The only component worthy of special note is R1, a resistance inserted in series with the grid circuit, close to the grid of the valve.

This is known as the grid stopper resistance, and it prevents any residual r.f. or i.f. voltages from reaching the grid of the valve where, in the case of a high efficiency type such as is being discussed, it might cause incipient or actual instability. Alternatively, the valve itself might oscillate at a very high frequency.

R1 may be anything from 5,000 to 100,000 ohms and is often situated in or close to the control grid connection to the valve, whether this be a top cap connector or a pin on the valve base, as it usually is in modern receivers.

How it works is as follows: the stopper forms with the input (grid/cathode) capacitance of the valve a potential divider across which the signal is developed. That which appears across the stopper is lost, and only that across the valve input is passed on. Almost the whole of the audio frequency signal is passed on, but because the valve input impedance is low at high frequencies, these appear almost completely across the resistor, and are lost.

CHAPTER 19

SECOND A.F. STAGES

In the previous section the various forms which the coupling between the demodulator and the first a.f. valve may take were described and illustrated.

We now come to the audio stage(s), which leads to the output valve (or valves). The circuit in which the demodulator is coupled directly to a high-efficiency output pentode or tetrode was at one time popular in smaller receivers, but the more general practice in larger receivers has been to have the demodulator coupled to a first a.f. valve, which in turn is coupled to the output valve. In this case, as was seen in the last section, the first a.f. valve is usually a triode, either on its own or in the same envelope as the double-diode demodulator and a.g.c. rectifier.

At this juncture it will be best to deal with mains receivers first, since battery models sometimes use different couplings. Undoubtedly the most popular arrangement for coupling the first a.f. valve to the second a.f. or output valve is the resistance-capacitance arrangement which, as was seen in the last section, is also more or less the standard form for the first a.f. coupling.

Fig. 38(a) shows the simplest form of resistance-capacitance coupling between the first a.f. valve (the triode section of a double diode triode) and the output valve (in this case a pentode). R1 is the triode anode load resistance, usually from 50,000 to 250,000 ohms except in special cases; C1 is the a.f. coupling capacitor (0.01 to 0.1 μ F); R2 the grid resistor of the output valve (250,000 to 500,000 ohms); R3 is the automatic bias resistance to suit the output valve, with C2, its by-pass capacitor (usually 25 or 50 μ F). C3 is a fixed tone correcting capacitor for the output pentode, which is quite distinct from any tone control device which may be fitted. Its value is usually between 0.001 μ F and 0.01 μ F.

Basically this circuit is the same as the elementary resistance-capacitance circuit shown in an earlier chapter. An elaboration of it is shown in Fig. 38(b). Here R5 corresponds to R1 of Fig. 38(a);

C6 to C1; R6 to R2; R8 to R3; C7 to C2; and C8 to C3. This leaves us with the additional components R4, C4, C5, R7 and R9.

R4 and C4 form a "decoupling" arrangement, which, incidentally, is often used in other anode and screen circuits in the receiver in a similar form. R4 tends to prevent a.f. currents from getting into the h.t. supply circuit, whence they might be fed to the anode circuits of other valves and give rise to instability. C4 completes the circuit to chassis for a.f. currents. It is much easier for these currents to return to chassis via C4 than via R4 and the h.t. supply circuit, and accordingly they take the line of least resistance and do not enter the h.t. circuit to any appreciable extent. The efficiency of the decoupling depends on the product of C4 and R4, and both should be as large as is convenient. In practice, the value of R4 depends on how much d.c. voltage drop from the h.t. line to the top of R5 can be allowed, and is usually of the order of 5,000 to 20,000 ohms. For C4 a value of 2 to 8 μF is common, the capacitor being of the electrolytic type.

C5, which is a by-pass capacitor for any residual i.f. currents which may have got as far as the anode of the first a.f. valve, will have a value of 0.0001 to 0.0005 μF .

R7 is a grid stopper for the output valve, having a value of from 5,000 to 100,000 ohms. Its use was described at the end of the last chapter. R9 is an anode stopper, sometimes used with high efficiency valves to assist in obtaining complete stability. It will

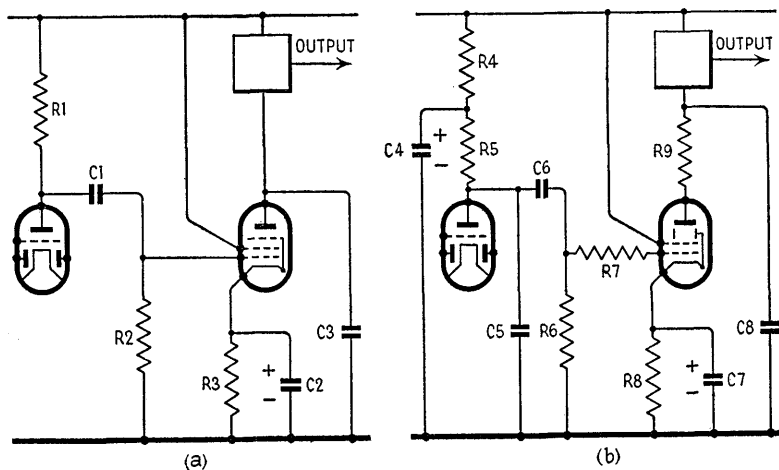

Fig. 38. Resistance-capacitance coupling circuits. On the left at (a) is a simplified arrangement, while (b) on the right contains a number of refinements

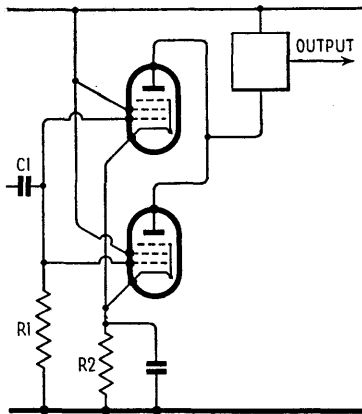

Fig. 39. Basic arrangement of two pentode output valves connected in parallel

usually have a low value, of the order of 50 ohms. Without it and R7, some large output valves will oscillate at a very high radio frequency, causing a mysterious inefficiency, distorting the reproduction, and may even radiate oscillation.

It will be noted that the output valve shown in Fig. 38(b) is not a pentode, but a beam tetrode. The two are more or less interchangeable, but in place of the suppressor grid in the pentode, connected internally to the cathode of the valve, the beam tetrode has its special beam-forming shields connected internally to cathode. Either valve can be used in either circuit, provided that both have similar characteristics.

Before leaving Fig. 38(b), it should be pointed out that some of the additional components shown may be omitted in individual sets—in fact, very few will have all those shown.

Where a large power output is required, either a single output valve which gives the requisite power can be used, or two or more lower-powered valves may be employed. If two valves are used (and it is very exceptional in domestic receivers to find more than two valves in the output stage) these valves can be connected in one of two ways—in parallel or in push-pull.

Paralleled output valves are a possibility, and they have actually been used in the past, but they are not found in modern receivers. Nevertheless, for the sake of completeness the arrangement is shown in Fig. 39. This shows two identical output pentodes connected in parallel, and it will be noted that the two cathodes, the two control

grids, the two screens and the two anodes are each connected together. C1 is the usual coupling capacitor, and R1 is the grid resistance common in both grid circuits. The screens are connected to the h.t. supply, and R2 is the common cathode bias resistance. Since the cathode current will be twice that of a single valve, the value of R2 will be half that which would be used for a single valve, so that the same voltage drop across R2, and therefore the same bias voltage, is obtained. The load impedance (shown by a square in series with the anode circuit) will also be half the value required by a single valve.

CHAPTER 20

PUSH-PULL CIRCUITS

When a greater power output is required than can conveniently be obtained from a single valve, push-pull transformer coupling is more likely to be employed than is a pair of valves in parallel. An example of this as applied to a mains receiver, and using two triode power valves in the output stage, is given in Fig. 40. It is a necessary condition in push-pull circuits that the two valves must work 180 degrees out of phase with each other, which means that the signal applied to one must be of opposite phase to that applied to the other. With transformer coupling this is easily arranged.

It will be seen that the inter-valve transformer T1 has its primary in the anode circuit of the first valve, R1 and C1 being the anode decoupling resistor and capacitor respectively. The ends of the secondary of T1 go to the control grids of the two triode output valves, while its centre-tap goes to chassis. In this way the a.f. voltages applied to the grids are made equal in value, but opposite in phase, which we have just seen to be a necessary condition for push-pull operation.

The output transformer T2 has its primary winding centre-tapped. The ends go to the anodes of the two output valves, while the centre-tap goes to the h.t. positive line. It thus feeds the anodes with h.t. supplies, while the a.f. outputs from the two valves are re-combined in-phase and fed to the loudspeaker from the secondary of T2.

A point to note about Fig. 40 is that the output valves in this case are of the directly-heated type. This is not a necessary condition, but it so happens that some large triode power valves are directly-heated. This affects the method of obtaining bias. With indirectly-heated valves, the two cathodes would be connected together and a common bias resistance, or two separate bias resistances, would be inserted in the leads from cathodes to chassis, after the manner shown in Fig. 41.

The method of obtaining bias in the circuit of Fig. 40 is different. The filaments of the valves are wired in parallel and are fed from a

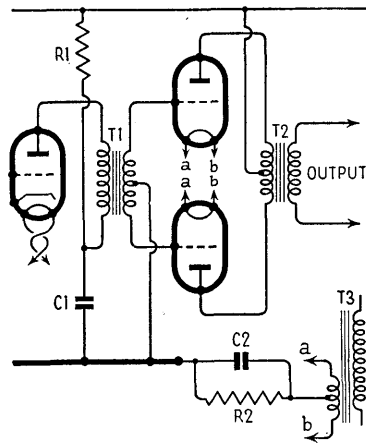

Fig. 40. A push-pull transformer-coupled output stage using two directly-heated mains valves. Note the method of obtaining grid bias in this case. When indirectly-heated valves are used, bias is obtained by the same means as is used in the output stage of Fig. 41

winding on the mains transformer T3, which is quite separate and distinct from that used to supply the other valves in the set. This winding is centre-tapped, and between the centre-tap and chassis is connected a resistance R2 which acts in the same way as a cathode bias resistance used with indirectly-heated valves. The h.t. current of the two valves flows through R2 and causes a voltage drop across it which is positive relative to chassis, raising the heater winding, and with it the valve filaments, to a positive voltage with respect to chassis. As the grid circuit of the output stage is returned to chassis via the centre tap of the secondary of T1, the grids are made *negative* with respect to the filaments by the amount of the voltage dropped across R2. C2 is a by-pass capacitor across R2.

CHAPTER 21

PUSH-PULL R.C. STAGES

In common with the general tendency in single-valve coupling circuits, resistance-capacitance coupling to the push-pull output stage is found more frequently than is transformer coupling. As we saw, the push-pull circuit is quite easily arranged where transformer a.f. coupling is used, but with resistance-capacitance coupling it is a little more intricate. It is also much more varied in design.

As we know already, valves in push-pull must be fed with signals of equal voltage but opposite phase, and the resulting separate anode currents, which are also in opposite phase, must be re-combined in such a way that they do not cancel each other out, but assist each other, as they did in the last chapter.

The difficulty with resistance coupling preceding the push-pull valves is to split up the signal in the correct manner. In most circuits a separate phase-splitting valve has to be used for this. One circuit which is used for this purpose is shown in Fig. 41. Here the output from the first a.f. amplifying valve is fed to the phase-splitting valve (usually a triode) via the coupling capacitor C1. R1 is the usual grid resistance, returned to the bottom of the bias resistor R3. Between this and chassis is another cathode resistance R4 which is equal in value to the anode load resistance R2.

The anode of the phase-splitter is coupled via C2 in the usual way to the grid of one of the push-pull output valves, but the other output valve is coupled by C3 to the junction of R3 and R4, in the cathode circuit of the phase-splitting valve. R5 and R6 are the grid resistors of the two output valves, and R7, shunted by C4, is the common bias resistance for the two output valves. The junction of R5, R6, R7 and C4 is returned to chassis.

The result of this arrangement is that, owing to a degenerative effect, the phase-splitting valve has a very low gain; in fact it gives very little amplification at all. However, the voltages at anode and cathode of a valve are always 180 degrees out of phase, and the signals at the anode of the phase-splitter and at the junction of

R_3 , R_4 are approximately equal in value, and as they are in opposite phase we have the requisite state of affairs for feeding the two output valves.

The anodes of the output valves are connected to the opposite ends of the primary winding of the output transformer T_1 , and the h.t. supply is fed into a centre-tapping. In this way both valves receive their d.c. anode supply, and the out-of-phase anode currents are re-combined at the output stage.

The diagram of Fig. 41 is a basic one and does not include decoupling, stopper or tone compensation arrangements, which will be similar to those shown in Fig. 38(b). The screen h.t. feeds are also omitted from our diagram.

Another method of resistance-feeding a push-pull pair is shown in Fig. 42, where advantage is taken of the fact that the voltages at the control grid and anode of a valve are always 180 degrees out of phase. Here the input from the preceding stage is fed via C_1 direct to one of the output valves. It is also fed via C_2 and the potentiometer R_1 , R_2 to the grid of a triode phase-reversing valve.

The values of R_1 and R_2 are so chosen that the input voltage to the triode valve is stepped down to an extent which just balances the amplification obtained in the valve. In this way the a.f. signal voltage at the anode of the triode can be made equal to that fed to C_1 and C_2 , but owing to the phase reversal introduced by the valve, it will be in opposite phase. It is fed via C_3 to the other output valve, and the rest of the circuit is the same as that in Fig. 41.

In a typical case where the actual amplification of the phase-reversing valve is about 15, R_1 is made 500,000 ohms, and R_2 is

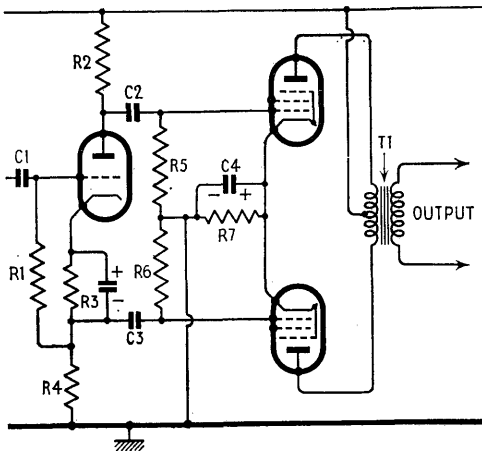
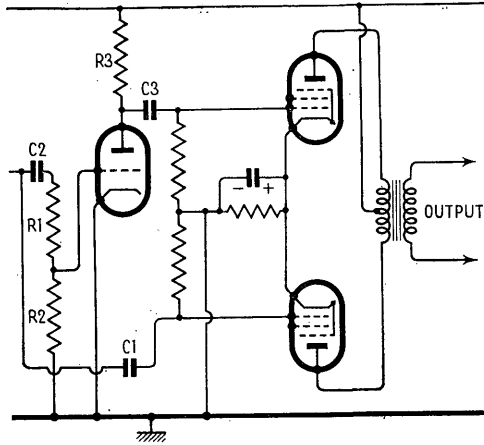

Fig. 41. Push-pull output circuit with resistance-capacitance coupling. The triode valve acts as a phase-splitter, with equal load resistance in anode (R_2) and cathode (R_4) circuits. R_3 is the normal bias resistance, and is therefore by-passed by an electrolytic capacitor

Fig. 42. Another form of resistance-capacitance coupling to a push-pull output stage. Here the triode reverses the phase of the signal applied to it. No cathode bias resistance is shown, but one of the same type as that of Fig. 41 might be used



35,000 ohms, so that the signal at the grid of the phase-splitter is about one-fifteenth of that which is applied to C1 and C2. Thus the signals applied to C1 and C3 will be roughly equal, and in opposite phase.

Push-pull output is not employed to a large extent in ordinary table-type domestic radio receivers, but it is quite common in radio-gramophones having a large power output, and in amplifiers of the high fidelity and public address types. It has the great advantage that one form of distortion, called second harmonic distortion, which is prevalent in triode valves, is balanced out. This faculty does not confer the same advantage when pentodes are used, however, because they introduce a form of distortion that is predominantly third harmonic, and push-pull operation does not balance that out.

In really high quality amplifiers, which are often distinguished from normal good quality amplifiers by the term Hi-Fi, or high fidelity, push-pull coupling is usually effected by high quality transformers.

CHAPTER 22

Q.P.P. A.F. OUTPUT

With the introduction of transistors into radio receivers the valve receiver has been almost completely eclipsed by them. Owing to the smallness of the transistor compared with the valve, and its comparatively modest demands of current and voltage, the battery-operated transistored portable receiver has become more popular than the table model, even for use in the home. In fact the only reason for making the normal domestic receiver larger in physical dimensions than a smallish portable model is in order to accommodate a good loudspeaker in it.

But there are still thousands of battery-operated portable receivers in use that employ valves, and prior to the introduction of the transistor, they and the mains/battery receivers were the only kind of portable models that were available to the ordinary home listener. They were, however, considerably less numerous than the mains receivers with which we have dealt so far. Their tuning and general receiving principles were very much the same as those of the mains receiver, but their power supply circuits were very different, they employed special battery valves, and their output stages usually operated in special kinds of push-pull circuits that enabled them to deliver an output power comparable in economy with that obtained from a mains receiver.

There were then in principle two special forms of push-pull which were often encountered in battery models. Both were designed to provide a large output with a minimum h.t. current consumption, low h.t. consumption being an important feature for the designer to achieve, in order to ensure an economical level of running cost for the user.

The actual circuit arrangements of these two special forms of push-pull are almost identical to each other and to that of normal ("Class A") push-pull. The difference lies in the valves, and the manner in which they are operated.

The first arrangement is known as “quiescent push-pull”, usually abbreviated to q.p.p. This depends for its special properties on the over-biasing of the push-pull output valves. If a single valve were employed with negative bias above normal, distortion would result, but by using two valves in push-pull the type of distortion produced by over-biasing is cancelled out. The effect of the excess bias is to reduce the “standing” or quiescent anode current of the output stage, when no signal is arriving, to a very small value. When an a.f. signal is fed into the stage, the grid of one of the output valves is made more positive (less negative) at the same time as the grid of the other valve is made more negative, and vice versa. Each valve only amplifies when its grid becomes less negative, its anode current rising with an increase in the signal voltage.

It is, of course, normal for the anode current of a valve to vary with the signal applied to its control grid, but then it varies, or “swings”, either side of its steady, or mean, value, and the average anode current over a period is constant. Whether the period is one minute or one hour, the average anode current is the same, with or without a signal. This is not so with q.p.p. valves, whose average anode current varies with the strength of the signal.

With large signals, the average anode current and the power output of the stage is the same as in a normal push-pull stage, but with small signals the average current is low. Thus during a musical

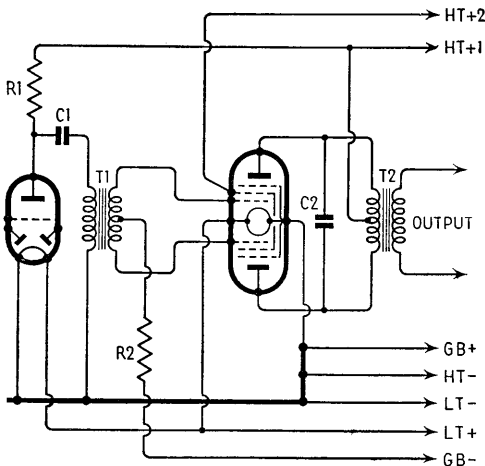

Fig. 43. Arrangement of a battery receiver output stage using quiescent push-pull in conjunction with a special double-pentode valve

programme, where the full output of the stage is only required for momentary peaks or crescendos, the average anode current over a period will show a distinct saving compared with an ordinary push-pull stage.

A q.p.p. stage requires twice the input voltage that a normal stage needs for a given power output, and consequently pentodes were usually employed on account of their superior sensitivity over triodes. Special double-pentode q.p.p. output valves were popular for use in this type of circuit, an example of which is seen in Fig. 43.

Here the primary of the q.p.p. intervalve transformer T1 is parallel-fed by resistance R1 and capacitor C1. The output valve is a special double-pentode in which the two suppressor grids are connected internally to one side of the double filament, while the two screens are also connected internally and brought out to a single pin, fed from the h.t. + 2 tapping. The two control grids are quite separate and are fed from the ends of the secondary of T1, the centre tap of which goes, via resistance R2, to a grid bias tapping. R2 is a stabilizing resistance of 100,000 to 250,000 ohms, which is usually fitted.

The anodes of the output valve go to the two ends of the primary of the output transformer T2, of which the centre tap goes to h.t. + 1. The secondary, of course, feeds the loudspeaker. C2 is a tone compensation capacitor across the primary of T2.

It will be observed that, except for the use of the special valve, the circuit does not differ from that of an ordinary push-pull stage. The difference lies in the design of the input and output transformers and the fact that the grid bias used is greater than would be the case in ordinary push-pull. It is usually between $7\frac{1}{2}$ and $10\frac{1}{2}$ volts, whereas half these values, or less, would be used for ordinary push-pull.

There is no reason why two pentodes of similar characteristics could not be employed in place of the special valve, but the latter is more convenient in use. When separate valves are used, it is usual to provide each with an independent screen grid tapping, so that h.t. voltages to the screens can be adjusted to secure a balance between the two valves.

CHAPTER 23

CLASS B A.F. OUTPUT

The second special form of push-pull formerly largely used in domestic battery receivers is known as "Class B" coupling. This also takes a small anode current under "quiescent" conditions, but differs in that the valves used are generally triodes with a high impedance, which operate with a very low value of bias and only take a small current by virtue of their high impedance.

When a signal is applied to such a stage, the grids of the valves are alternately made more negative and more positive. Under more negative conditions, the valve concerned does not amplify, since the anode current is practically cut off, but with the grid under "more positive" conditions, the valve does amplify, and with the push-pull arrangement the distortion which would arise is cancelled out, as it was in the q.p.p. system.

When the grid of one of the valves is made positive, however, another effect takes place, which does not occur in q.p.p. coupling. Grid current flows in the grid circuit, which, in any ordinary a.f. stage, must not be allowed to occur. With Class B coupling, arrangements are made whereby grid current can be handled. The flow of grid current necessarily involves a consumption of a.f. power in the grid circuit of the output stage, and this power must come from the preceding stage. Therefore, with Class B coupling, the preceding valve must be arranged to supply power to drive the grid circuit of the output stage without itself becoming overloaded. It is usual to call this preceding stage the "driver" stage, and it consists of a "driver" valve (usually a lower-power triode) coupled by a Class B "driver" transformer to the output stage. The driver transformer is specially designed for the job, and its windings have a low resistance and are capable of handling power, not only in the primary, but in the secondary as well. The ratio of the driver transformer is usually low.

The complete circuit is shown in Fig. 44. Once again a special valve is used in the output stage, this time consisting of two

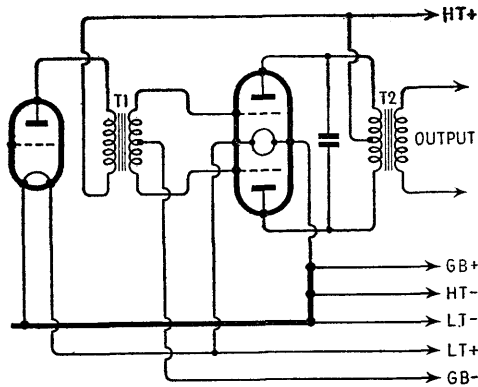

Fig. 44. A Class B output stage in a battery model, using a special double-triode valve

high-impedance triodes in the same envelope. Two separate valves of similar characteristics could be used.

The first valve is the driver, coupled by the driver transformer T1 to the double output valve. The centre tap of its secondary goes to a low value of grid bias, and in some sets may even be found to go to chassis, thus operating without external bias. T2 is the output transformer arranged in the usual way, with a tone compensation capacitor across its primary winding. Note that there is no resistance in the grid bias lead in this case.

A point about both q.p.p. and Class B stages which does not emerge from a study of the circuit diagrams is that the h.t. supply, owing to the fluctuating demands upon it which are characteristic of both these stages, must be of good "regulation". This means that the h.t. voltage must not vary appreciably with the working load. If it does vary, distortion is likely to be introduced. An h.t. battery in good condition fills the requirements, but a partially discharged one, or one which has developed a high internal resistance, will not be satisfactory. If an h.t. battery eliminator is used with a set of this type, trouble is often encountered unless the eliminator has been specially designed for q.p.p. or Class B supply.

CHAPTER 24

LOUDSPEAKER ARRANGEMENTS

As was seen in the preceding chapters, the final stage of a.f. amplification feeds the output valve or valves, and the a.f. power in the anode circuit of the output stage is passed on, via a suitable transformer, to the loudspeaker. This transformer may be mounted on the chassis of the receiver or on the frame of the loudspeaker, but its use is the same in each case.

All modern receivers employ a moving-coil type of loudspeaker, with the winding of the speech coil of low impedance. The anode circuit of the output stage is of high impedance, and since for maximum transference of power the impedance of the load should equal the impedance of the source, the output transformer is used for matching the loudspeaker speech coil to the output stage. For instance, a beam tetrode output valve may have a recommended matching impedance of 2,000 ohms, while the loudspeaker used with it may have a coil impedance of 5 ohms. In order to arrive at the correct ratio for a suitable matching transformer, 2,000 is divided by 5, and the square root of the result gives the correct ratio. In this case it works out at 20, so that the transformer has a 20 to 1 step-down ratio.

Moving-coil loudspeakers may be of the permanent-magnet type, or they may have an electro-magnet energized from the h.t. supply of the receiver. In later years, the permanent-magnet speaker completely displaced the energized type in ordinary domestic receivers, the use of new magnet steel alloys having enabled very efficient p.m. speakers to be made comparatively small in size and light in weight.

Fig. 45(a) shows the output circuit with a permanent-magnet loudspeaker. Here T1 is the output transformer with its primary in the output valve anode circuit (with push-pull circuits the primary will be centre-tapped, as was explained earlier) and its secondary leads connected to the loudspeaker speech coil L1. A connection is shown from the speaker frame (on the right of (a)) to chassis. This is not always present, but when it is it serves to earth the frame.

In a.c./d.c. sets, when it is used, this connection will be taken to true earth, and not to chassis, if it is used at all. The dotted connection shown earths the secondary of T1 and the speech coil, and again it may or may not be present.

The electro-magnetic type of moving-coil loudspeaker (usually referred to as the "energized" type) is a little more complicated. It has a speech coil fed from a matching transformer as before, but in addition the energizing or "field" coil is connected in circuit. In loudspeakers of this type there is usually also a third coil, known as the hum neutralizing or hum "bucking" coil, which is associated with the speech coil circuit. Fig. 45(b) shows a typical energized moving-coil speaker circuit. T2 is the output transformer with its secondary connected with one side to L2, the other side to L3, L2 and L3 being connected in series. L2, of course, is the loudspeaker speech coil, while L3 is the hum neutralizing coil.

L4, the loudspeaker field or energizing coil, is in this case connected from the cathode of the h.t. rectifier to the h.t. positive line. When we examine the power supply circuits later it will be seen that in this position the field coil is in series with the h.t. positive supply lead to the set, and acts as a smoothing choke, at the same time becoming energized by the h.t. current which flows through it.

In a minority of receivers L4 may be connected in series with the *negative* h.t. supply lead to the set, in which case one end will be connected to chassis and the other to the centre-tap of the mains transformer h.t. secondary winding, as shown in Fig. 45(c), when it will still operate as a smoothing choke.

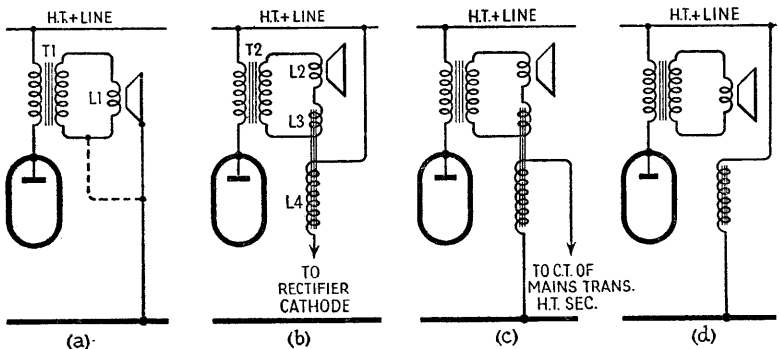

Fig. 45. Four types of moving-coil loudspeakers: (a) connections of a moving-coil speaker with a permanent magnet; (b) one with an energized, or electro-magnetic, system with its field magnet winding in series with the positive h.t. lead; (c) same as (b), but with magnet winding in the negative h.t. lead; (d) same again, but with magnet winding connected across the h.t. circuit

In both these arrangements the resistance of the field winding will be between 500 and 2,500 ohms, common values being 1,000 or 1,200 ohms. Occasionally a receiver will be found in which the field coil is not used for smoothing purposes in series with the h.t. supply, but is connected directly across the h.t. supply for energizing purposes, from the h.t. positive line to chassis, as shown in Fig. 45(d). In this case the resistance of the winding will be higher, usually between 6,000 and 8,000 ohms. This connection is often found in a.c./d.c. midget receivers originally intended for use on 110 V mains, where the series connection of the field would cause a drop in h.t. voltage which would reduce the voltage on the h.t. line too much. The parallel connection avoids this. In such cases the hum neutralizing coil is usually omitted.

Referring again to Fig. 45(b), it will be seen that the hum neutralizing coil L3 is represented as being iron-cored and wound on the same core as the field. This is so, for the coil usually consists of a few turns of wire wound either at the side of the field winding in pancake formation or as a single layer winding over the field coil.

When the field coil L4 is energized by unsmoothed h.t. current, there is a tendency for hum voltages to be induced into the speech coil L2, which will produce a loud hum in the loudspeaker. With the coil L3 wound so that it is coupled to the field coil, hum voltages are introduced into it also, and by connecting L3 in series with L2 in the sense such that its hum voltage is in opposite phase to that of L2, the resultant hum in the speech-coil circuit is largely cancelled out. It is not reduced entirely to zero, however.

The hum neutralizing coil, being more tightly coupled to the field coil than is L2, can consist of fewer turns of thick wire. Consequently, its impedance is low (its d.c. resistance is usually only about 0.1 ohm) and the a.f. power lost in it is very slight. It is important to remember that the connections of L3 must not be reversed relative to L2, otherwise the hum voltages will be additive, and a loud hum will be produced.

In most sets provision is made for the connection of an external loudspeaker, by means of sockets or terminals. Fig. 46 shows some of the many arrangements. At (a), the sockets are placed so that the external speaker is connected across the primary winding of the output transformer. In this case a high impedance external speaker (or an ordinary moving-coil type fitted with its own input transformer) must be used.

The switch S1 is sometimes fitted to permit the internal speaker to be muted, but it should be noted that S1 must not be opened until after the external speaker is connected, otherwise the h.t.

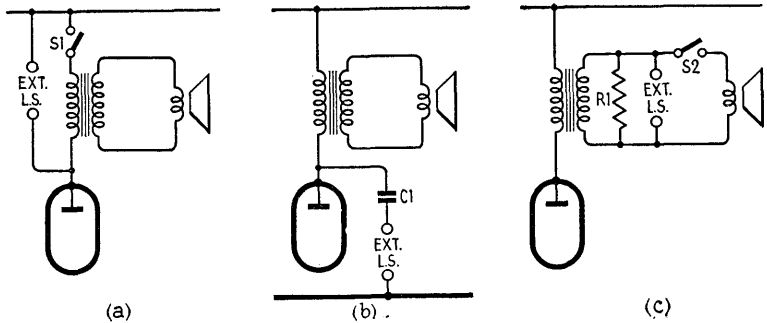

Fig. 46. Three arrangements for the connection of external speakers. If the output valve at (a) is a pentode, switch S1 must on no account be opened to mute the internal speaker unless the external speaker is actually connected

supply to the anode will be interrupted and if the valve is a pentode it will run red-hot. Another arrangement for using a high impedance external speaker is shown at (b) in Fig. 46. The speaker is fed from the anode of the output valve via the d.c. blocking capacitor C1, the other side of the speaker being connected to chassis. In this case no d.c. flows through the windings of the speaker or its transformer. A muting switch connected as in Fig. 46(a) cannot be used with this arrangement.

A more usual arrangement in modern sets is for the external loudspeaker sockets to be arranged as in Fig. 46(c). They are connected across the secondary of the output transformer, and this involves the use of a low impedance external loudspeaker (a moving-coil type without a transformer of its own). Switch S2 is often provided to disconnect the speech coil of the internal speaker, thus muting it. Occasionally a resistance R1 of perhaps 50 ohms is permanently connected across the secondary of the output transformer to act as an artificial load in case S2 is opened before the external speaker is connected up. Alternatively, S2 is sometimes in the form of a jack switch, arranged to be operated only when an external speaker is plugged in.

With increasing interest on the part of domestic receiver users in the quality of reproduction, it has become the current practice in better class receivers to use more than one speaker, even in table-type receivers. The complete speaker system is usually based on the conventional type of moving coil speaker of the kind we have just been discussing, but now one speaker need only provide an output in the lower half of the sound frequency spectrum. A second speaker, either of the moving coil variety or, in the more

expensive receivers, of a different type, would then produce the upper half of the audio frequency range. There may even be three speakers of different types, and in really ambitious radiograms as many as five speakers might be used, although it is unlikely that they would all be different from one another.

When two speakers are used in a well-designed receiver, the lower-frequency, or bass, speaker usually operates only up to something between 1,000 and 2,500 c/s, and the high-note speaker covers the rest of the range. Normally the second speaker will also be of the moving coil type, but it will be smaller than the bass speaker, the cone diameter of the one being perhaps half that of the other. Occasionally, however, the second speaker might be of a different type, such as an electrostatic or a ribbon speaker, but that would only be found in a really expensive receiver.

When combinations of two or three speakers are employed it is usual to feed them only with their respective range of frequencies, and this is done by connecting them to the output valve via filter circuits that permit only the appropriate band of frequencies to reach each speaker. Such filters are called "cross-over" filters, because they determine the frequency at which they cross over the signals to one speaker or the other.

A convenient arrangement of three speakers is shown in Fig. 47. Two of the speakers are alike, and they reproduce the bass range only, and in order to prevent the higher frequencies from reaching them they are fed via the choke L1, which impedes the higher frequencies. The use of two speakers in parallel like this gives a

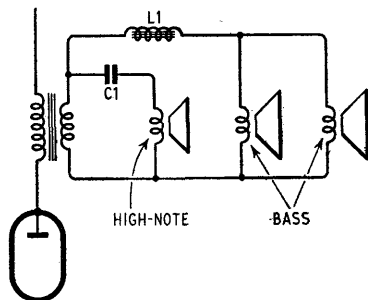

Fig. 47. A multi-speaker arrangement employing three moving-coil units and a simple type of cross-over system L1, C1. The high-note speaker is sometimes called a "tweeter"

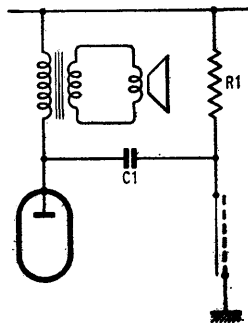

Fig. 48. A simple two-unit multi-speaker system using a moving-coil low-note speaker and an electrostatic high-note speaker

great improvement in bass reproduction, but it is essential that they are both connected in the same phase, so that both cones move outwards or inwards together. Otherwise, instead of reinforcing each other, they tend to neutralize each other, and the bass is weak.

The high-note speaker here is also a moving coil unit, but it is smaller than the others, and to prevent low frequency signals from reaching it, it is fed via a capacitor C1. In many cases the speaker is of such a design that it might actually be damaged if the bass frequencies reached it without the attenuation imposed by the capacitor. In other cases it is permissible to dispense with the choke, and sometimes also the capacitor.

A similar arrangement in which an electrostatic speaker is used for the higher frequencies is shown in Fig. 48. An electrostatic speaker requires a polarizing voltage, which can be obtained from the h.t. circuit, so there is usually a resistance R1 feeding it from a high tension source. The resistance must be high enough to prevent damage if the two plates of the speaker touch, and in fact in really good electrostatic speakers its value has an important effect on their performance. No d.c. current need flow through the resistance, however, so it can be very high. There must be a path of lower resistance for the signal, though, so the speaker is coupled via a capacitor.

In many of these cases the h.t. supply of the receiver can be used as the high tension source. In some very elementary arrangements using small rigid speaker diaphragms the capacitor and resistor are both dispensed with, and the electrostatic speaker is connected directly to the anode of the output valve, where it receives the signal and the polarizing potential at the same point. This type of electrostatic speaker operates only at the very high frequency end of the audio spectrum, itself producing only rather squeaky sounds.

The cross-over network is not usually necessary with simple moving coil/electrostatic combinations of the kind shown in Fig. 48, although it might be in more elaborate arrangements. Normally the capacitor C1 is sufficient, simply to protect the electrostatic speaker from damage.

CHAPTER 25

A.C. POWER SUPPLIES

In previous chapters we have covered the various circuit arrangements of typical superheterodyne receivers from the aerial input to the loudspeaker output. For the most part, the main receiving circuit has been dealt with, to the exclusion of subsidiary circuits which, however, must be included before any review of the circuit arrangements can be considered complete.

The power supply circuits of mains receivers are, of course, of paramount importance, and will be described next. In the case of battery receivers, operating simply from l.t., h.t. and g.b. batteries, the power supply needs very little comment. The principle of obtaining grid bias voltages automatically, thus disposing of the need for a grid bias battery, is used in many valved battery sets, the usual technique being to utilize the voltage drop across the resistor or resistors connected in series with the negative h.t. lead.

In a mains receiver we have to obtain low tension, high tension and grid bias supplies entirely from the mains, and the method of accomplishing this has been more or less standardized in valved receivers.

Taking the early receivers for use exclusively on alternating current mains first of all, in general the necessary power is obtained from a mains transformer. For the low tension supply for the valve heaters "raw" a.c. is used. This obtained from a low voltage secondary winding on the mains transformer. The winding may have a centre tapping, connected to chassis, although more commonly one side of the secondary goes to chassis.

In most a.c. receivers the heaters of the valves will all have the same voltage rating, and will be connected in parallel with the heater secondary. In cases where a different voltage is required by one or more of the valves, a separate secondary, or a tapping or extension on the existing secondary, will be used. The rectifier valve normally employed for the h.t. supply may or may not have its own heater secondary. It must be isolated from the other valves,

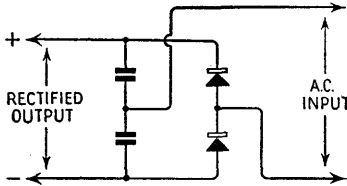

Fig. 49. Basic circuit for metal rectification on the voltage-doubler system

obviously, and at one time it was always provided with its own winding, but since the introduction of valves with adequate heater/cathode insulation it is generally run from the common secondary winding.

In order to obtain the necessary d.c. h.t. supply from a.c. mains it is usual to step the mains voltage up to the amount required, rectify and smooth it. In the past various types of rectifier have been employed, including the valve and the "metal" (dry-contact) rectifier. Certain early receivers employed the latter, operating on what is known as the "voltage-doubler" system. The circuit of a metal rectifier connected in this system is shown in Fig. 49. No smoothing circuit is shown, and it should be pointed out that the two capacitors (usually about $4 \mu\text{F}$ each) form an important part of the actual rectifying circuit, and their value is fairly critical.

Turning to valve rectification, which will be found in many valved mains receivers, it is quite common for half-wave or full-wave circuits to be found. But for a.c. only full-wave rectification is more or less standard, so this will be dealt with first. Half-wave circuits are used mainly in a.c./d.c. receivers, and these are more

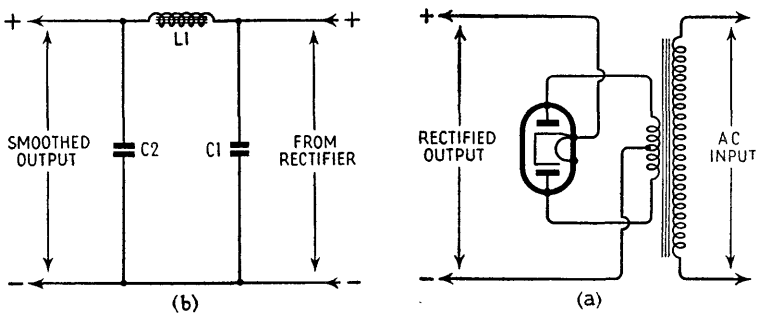

Fig. 50. The basic full-wave rectifying circuit in association with a double-wound mains transformer for use with a.c. mains is shown at (a). Usually the primary winding is tapped to provide adjustment to suit the voltage of the a.c. input voltage. The smoothing circuit at (b) is one that might well be used with the rectifier at (a)

common than conventional a.c. mains receivers by a considerable margin.

The basic circuit of a full-wave valve rectifier is shown in Fig. 50(a). The mains supply is fed into the primary of the mains transformer, and is stepped up to the required voltage by a suitable secondary winding, having a centre-tap. The total voltage across the secondary in full-wave rectification is usually about twice the d.c. voltage output required.

The full-wave rectifier valve has two anodes, each one of which is connected to one end of the h.t. secondary winding of the transformer. The heater of the valve (which may be of the directly- or indirectly-heated cathode type) is fed from a separate low-voltage secondary winding on the mains transformer (not shown in Fig. 50(a)). The rectified output is obtained from the centre-tap of the h.t. secondary (negative) and the cathode (or one side of the heater) of the valve (positive).

The rectified current, as obtained from the circuit of Fig. 50(a), is unidirectional, but pulsating (at a frequency twice that of the mains supply). It is, therefore, not suitable for the h.t. supply to a receiver until it has been smoothed. The simplest circuit for this purpose is shown in Fig. 50(b), where an iron-cored choke L1 is used in series with the positive supply lead, and two large capacitors of the electrolytic type are connected across the supply, one on either side of the choke. This is called a capacitance input smoothing filter. C1 is the "reservoir" capacitor and C2 the smoothing capacitor.

The choke may be replaced by the field winding of an energized moving-coil loudspeaker, as was mentioned in the previous chapter, and it may be in series with the negative supply lead in some sets. This permits grid bias to be derived from the voltage drop across the field, because as is explained later, the potential drop along the coil is then negative with respect to chassis.

Occasionally an extra section may be added to the smoothing filter in elaborate sets, consisting of an additional choke in series with the supply and a further capacitor in parallel. In a few receivers the smoothing choke may be replaced by a resistance in conjunction with capacitors, and this resistance-capacitance smoothing arrangement is now much more common than it was in pre-war receivers.

A practical power supply circuit for an a.c. receiver is shown in Fig. 51. Here T1 is the mains transformer, with a primary winding tapped for different mains voltages, and a switch S1 for on-off switching. Note that the core of the transformer is earthed to the

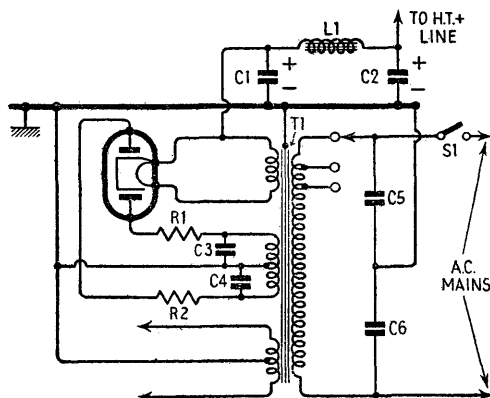

Fig. 51. A complete practical circuit of the power supply section of an a.c. receiver, using a full-wave rectifier. The smoothing choke is in the positive h.t. lead. Several refinements are shown which are not always present in commercial receivers

chassis of the receiver. Sometimes a screen, also earthed, is incorporated in the transformer between primary and secondary to reduce the possibility of mains-borne disturbances entering the receiver circuits.

The transformer has three secondaries. The lowest in the diagram supplies the l.t. requirements of the receiving valves (and scale lamps, if used). It is centre-tapped, with the tapping earthed. The valve rectifier heater is supplied by a separate l.t. winding, one side of which forms the positive connection to the smoothing circuit. The third secondary winding is for the h.t. supply to the rectifier valve, its ends going to the anodes of the rectifier. The centre-tap forms the negative h.t. connection, and goes to chassis (earth). The smoothing circuit consists of the choke (or loud-speaker field) L1 and the electrolytic capacitors C1, C2. Note their polarity and the fact that since each negative connection goes to chassis, it is possible to use a double capacitor unit, having a common negative lead, but two separate positives.

This arrangement of two electrolytic capacitors is so common that double units are made specially for the purpose. Often they have a tubular metal case which forms the common negative connection, and this is connected to chassis by means of a metal clip in which it is mounted. The two colour-coded positive connections are mounted on an insulating panel at one end of the case. The values of the two capacitors are usually $8 + 8 \mu\text{F}$, $16 + 16 \mu\text{F}$, or $8 + 16 \mu\text{F}$.

Fig. 51 also shows some additional components, some or all of which may be employed in certain receivers. They are refinements, however, and are not essential to the operation of the circuit. R1

and R2 are low-value (50 to 100 ohm) resistors inserted in series with each anode circuit of the rectifier for h.t. current surge-limiting purposes. They also act to some extent as r.f. stoppers. C3 and C4 by-pass to earth any parasitic r.f. currents which may be introduced into the rectifier circuit. Their value is usually of the order of $0.01 \mu\text{F}$.

C5 and C6 are mains r.f. by-passes, and they form a filter which to a certain extent suppresses mains-borne interference. It will be seen that their common connection is earthed. Occasionally a single capacitor, connected between one side of the mains input and chassis, is employed. Values of $0.01 \mu\text{F}$ are common for these capacitors.

It has been mentioned that in certain cases the smoothing choke (or speaker field) may be inserted in series with the *negative* h.t. lead. Fig. 52(a) shows part of the circuit of Fig. 51 re-drawn with the choke L1 in the negative lead, from the centre-tap of the h.t. secondary of the transformer to chassis. The rectifier cathode then goes directly to the h.t. positive line. Note the new positions of the smoothing and reservoir capacitors C1 and C2, which are still one each side of the choke. In this case, however, they have a common positive connections to the h.t. positive line, and two separate negative connections.

With the choke connected as shown, the d.c. voltage drop across it, due to the total h.t. current of the receiver flowing through it, may be used, if desired, for automatic grid bias purposes. The

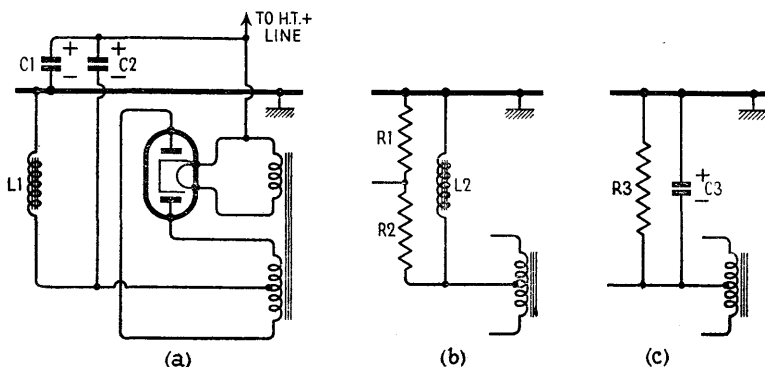

Fig. 52. The smoothing choke of Fig. 51 may be connected in the negative h.t. lead, as shown here at (a), and a potential divider might be connected across it (b) to provide grid bias potentials. Grid bias can still be obtained similarly in the absence of a choke by the insertion of the resistance R3 in the negative h.t. lead as shown at (c)

lower end of the choke is negative, relative to chassis, by the amount of the voltage drop, so that any valve in the set may be given this value of bias by connecting the cathode of the valve to chassis, and the grid return circuit to the bottom of the choke.

In most cases the total voltage drop across the choke (or speaker field) will be too high for normal bias requirements, in which case suitable tappings are sometimes provided, but more usually a potential divider is connected across the choke with one or more tappings as required. This is shown in Fig. 52(b), where L2 is the choke and R1, R2 form the potential divider. The total resistance of a divider connected in this way will be fairly high, of the order of several hundred thousand ohms, in order to prevent any appreciable h.t. current from by-passing the smoothing choke.

In cases where the choke or speaker field is in the positive h.t. lead, bias can still be obtained by utilizing the voltage drop across resistors inserted in the negative h.t. lead, as shown in Fig. 52(c). R3 is the bias resistor through which the total h.t. current of the receiver passes. A chain of several resistors could be used to provide more than one value of bias voltage. The resistors used will in this case have low values, of the order of 20 to 100 ohms, depending on the bias required and the h.t. current drawn by the receiver.

Sometimes a by-pass capacitor (C3) is connected across the bias network. This will have a value of the order of 50 μ F, and it should be noted that its *positive* lead will be connected to chassis.

The methods of obtaining bias described above merely supplement the usual method of using a suitable resistor in series with the cathode lead of each individual valve with the grid circuit in each case returned to chassis. This is called cathode bias, and it was explained in an earlier part of the book.

CHAPTER 26

A.C./D.C. POWER SUPPLIES

The problem of power supplies for receivers which operate from d.c. or a.c. mains at will is a somewhat different one from that of purely a.c. mains receivers. As has been seen, the advantage of an a.c. supply is that it can readily be transformed up or down, as necessary, in order to provide power at the correct voltage for low-tension and high-tension requirements. This is not readily possible in the case of d.c. supplies, for although a reduced voltage can be obtained by the use of series resistors, an increased voltage involves the use of a rotary transformer or a complicated conversion to pulsating current, static transformation, rectification and subsequent smoothing. The disadvantage of a series resistance to cut down the mains voltage to the lower value required for the heater supply of normal valves is that considerable power is lost in the resistor, heat is produced, and it is wasteful. Apart from this, however, there is no reason why this method cannot be employed.

In order to economize in power as far as possible, it is customary to wire the heaters of the valves in an a.c./d.c. receiver in *series* with each other, the only proviso here being that the heaters must all be rated to consume the same *current*. It is important to notice that in an a.c. receiver, with parallel heater connections, the heaters must all operate at the same voltage, but the current consumption can vary from valve to valve. In an a.c./d.c. receiver, with series heater connections, all the heaters must operate at the same current, but their voltages may be different.

With a view to reducing the value of the series resistor necessary in the heater circuit of an a.c./d.c. receiver, it is customary to use valves with higher heater voltages than usual; voltages ranging from 6 to 70 are in common use, while the heater currents have been more or less standardized at the present time at one of four different values—0.3, 0.2, 0.15 and 0.1 amperes.

It is the latter two ranges of valves which usually have the higher heater voltages, and it is common to find American receivers

designed for use on 110 V mains, whose total heater voltage adds up almost to the full mains voltage, so that only a small series resistance is needed in the heater circuit.

It is customary to arrange the heater circuit of an a.c./d.c. receiver in a definite order, since one end of the heater chain will be at a fairly high potential relative to earth, and there is always a tendency for hum voltages to be introduced into the valve in that condition. A typical arrangement of the heater chain of a simple superhet is shown in Fig. 53. The low potential end of the heater circuit goes

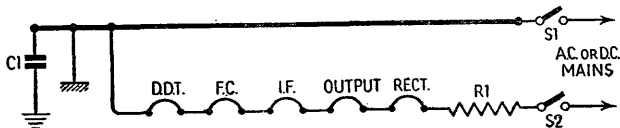

Fig. 53. Diagram showing the principle of connecting the valve heaters in series, together with a ballast resistance. The chassis is isolated from earth by C1

to chassis, which is also connected to one side of the mains via the switch S1. The chassis must, however, be isolated from direct connection to earth, and this can be done by means of the blocking capacitor C1 of about $0.05 \mu\text{F}$, the reason for which will be seen later.

The first valve, starting from the low potential end of the chain, will be the demodulator, usually a double-diode-triode, because hum is more prone to be introduced into this valve than any other. Next comes the frequency-changer, whose output, being considerably amplified, must be kept as free from hum as possible. Next in the chain is the i.f. valve, and the following this is the output valve. Any hum introduced here is only very slightly amplified. Finally, there is the h.t. rectifier valve, where hum is present anyway. The series ballast resistance R1 completes the chain, and is connected, usually via a second switch S2 (which is ganged with S1) to the other side of the mains.

If a combined demodulator and output valve is used (such as a double diode pentode), this valve will usually become the first in the chain from the low potential end, on account of its demodulator section.

The resistor R1 may be a wire-wound component, tapped for different mains voltages, or it may be a "line cord" resistance incorporated in the mains lead, or even a plug-in resistance "tube", resembling a valve in external appearance.

Another alternative is a barretter lamp, which is a special form of resistance device (often of iron wire in a bulb filled with hydrogen

gas) which has the property of keeping the current flowing through it sensibly constant over a wide range of applied voltages. Very often ordinary ballast resistors are described as barretters, but actually the term should only be applied to the self-regulating type of ballast.

In some a.c./d.c. receivers valves of mixed heater currents may be found, but in this case an arrangement of series/parallel heater wiring is used. Thus two 0.15A valves of the same voltage may be wired in parallel, to produce a 0.3A unit, which can be connected in series with a 0.3A valve chain. Other arrangements of a similar nature can also be employed.

If scale or indicator lamps are needed in an a.c./d.c. set, they are usually wired in series with the heater chain. It should be noted that they must be rated at the same current as the valve heaters, and should one fail, the heater circuit will be interrupted and the set will stop working. Sometimes they are shunted by a by-pass resistor to avoid this, but in any case they should be replaced as soon as possible.

There is a device called a "thermistor" which has the property of possessing a very high resistance when cold, and falling to a very low resistance when hot. The scale lamp(s) may be shunted by one of these, and because the lamp by-passes the current the thermistor remains cold. If the lamp fails, however, the heater current passes through the thermistor, heating it up and lowering its resistance until it takes the place of the lamp and permits the set to work until the lamp is replaced. A thermistor is shown in diagrammatic form in Fig. 54.

Another and more important application for the thermistor arises in connection with the series chain of heaters in an a.c./d.c. receiver. When cold, the valve heaters have a very low resistance, with the result that upon switching on the set a very high current flows until the heaters warm up, when the current settles down to its rated value. The high current does no harm to a valve if it does not cause over-heating, but if one valve becomes fully heated more quickly than the rest, the high current flowing through it can over-heat it. If a thermistor is inserted between, say, R1 and the rectifier heater in Fig. 53, its high resistance will prevent high currents from flowing until it has reached its operating temperature, and by that time the whole series of heaters will have slowly heated up with it, and none can be over-run. A thermistor is seen in Fig. 54.

We now come to the h.t. supply circuit of an a.c./d.c. receiver, and the point to note here is that the h.t. voltage is limited by the mains voltage, since one cannot transform d.c. to a higher voltage

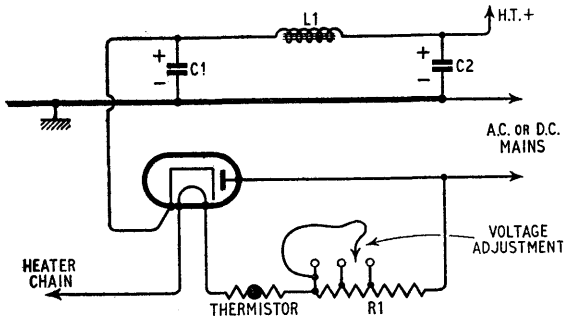

Fig. 54. A half-wave rectifier used to obtain the h.t. supply in an a.c./d.c. set

very readily. Early sets which were operated on d.c. merely used a smoothing filter for their h.t. supply from the mains, but the later type of a.c./d.c. set obviously needs a rectifier when the set is used on a.c. Fortunately, the insertion of a rectifier in a set does not introduce any complication when the mains happen to be d.c. for the rectifier valve under these conditions merely acts as a resistance of low value. In fact, the rectifier is advantageous even on d.c. mains, because it prevents the d.c. mains from being applied in reverse polarity if the mains plug is accidentally reversed. If electrolytic smoothing capacitors are used, the rectifier is almost essential for this reason.

The usual rectifier arrangement in an a.c./d.c. set is shown in Fig. 54, where a half-wave rectifier is used. The end of the heater chain with the rectifier heater and ballast resistance R_1 is shown. From the same side of the mains a connection goes (usually directly) to the rectifier anode; from its cathode is taken the unsmoothed positive h.t. supply, which is subsequently smoothed by the usual filter L_1, C_1, C_2 .

The negative h.t. connection is the other side of the mains, which, of course, goes to chassis. The need for a capacitor (C_1 in Fig. 53) to isolate the chassis from direct connection to earth can be seen when one realizes that one side of the mains supply is always earthed at the power station. If this side happens to be the same side as is connected to chassis in the receiver, then the chassis would be at or near to earth potential, but even then it would be dangerous to connect it directly to earth. Without testing, however, one cannot be sure of this, and it may prove that one side of the mains is earthed at the power station, and the other side at the receiver. This would put a short-circuit on the mains supply, blowing the house fuses.

The use of a capacitor between true earth and the chassis obviates this, while still placing the chassis at earth potential as far as r.f.,

i.f. and a.f. currents are concerned. Incidentally, it will be realized that in an a.c./d.c. receiver, if it is connected to the mains by means of a reversible plug, the chassis, and any metal parts connected to it, will very likely be at the full mains potential relative to earth, and care should be taken when handling a receiver under these conditions while it is out of its cabinet, because it is very dangerous.

For this reason alone, any receiver should be connected to the mains via a non-reversible three-pin plug, but it ought to be regarded as essential with an a.c./d.c. receiver. There is a recognized standard method of connection to electrical wall sockets that ensures the safety of an a.c./d.c. receiver on a.c. mains, provided of course that the leads from the receiver are properly connected to the plug. The method of connection is shown in Fig. 55, where the black (chassis or earthy) lead can be seen to go to the left-hand pin. At the wall socket, this pin goes to the neutral, the side of the mains that is earthed at the power station.

With d.c. mains, of course, there is no choice about it, as the polarity must be correct for the set to work, so in some cases the chassis might be "live" and dangerous. The non-reversible plug

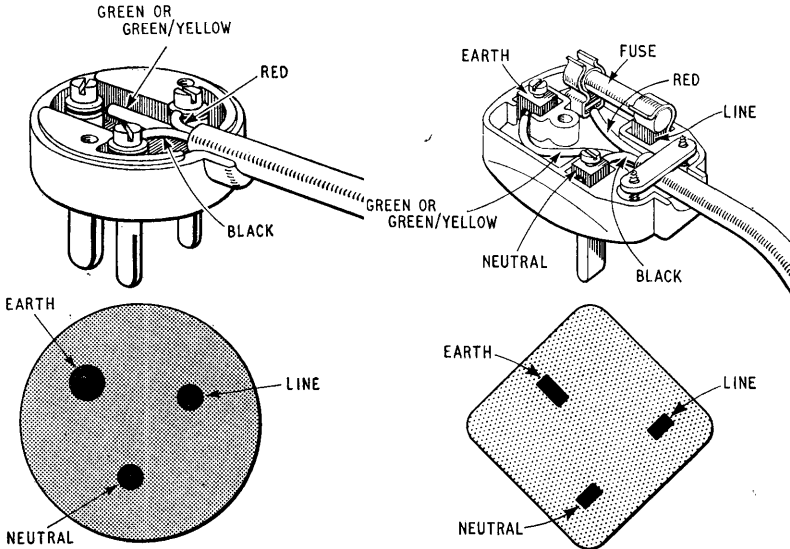

Fig. 55. The correct method of connecting the mains lead of a receiver to a 3-pin mains plug is shown here, a 13A plug on the right and a round-pin plug on the left. In each case the plug is viewed from its upper side, with the cap removed and pins pointing downwards. The colours shown for the cables apply to the U.K. only. Below each plug is shown the surface of the wall socket into which it is inserted

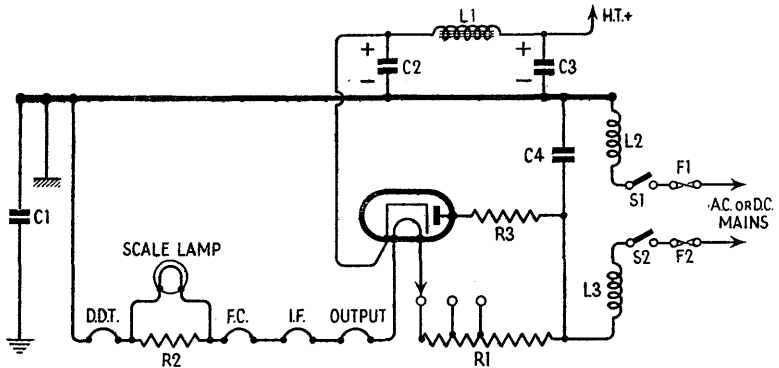

Fig. 56. Complete a.c./d.c. circuit for heater and h.t. supply, showing refinements, some or all of which may be present in actual receivers

then still has the advantage that the polarity will always be correct, because the plug cannot be inserted the wrong way round. An advantage of the three-pin plug with a.c. mains receivers is that the third pin provides a method of earthing the metal parts of the set that might be touched by the user, thus rendering them safe.

As in the case of a.c. receivers, a.c./d.c. models often include certain refinements in their power supply circuits. A complete circuit, showing various refinements, appears in Fig. 56. Some or all of the extra components shown may be present in a receiver.

F1 and F2 are fuses in series with each mains lead, while S1 and S2 form the double-pole mains switch. L2 and L3 are low-resistance air-cored r.f. chokes which, combined with the by-pass capacitor C4 (of about $0.1 \mu\text{F}$), form a filter which prevents mains-borne r.f. interference from entering the receiver. R1 is the ballast resistor, tapped for mains of different voltages. If a regulating barretter is used, no mains adjustment is necessary.

The heater chain is as in Fig. 53, except that a scale lamp, shunted by a resistor R2, is interposed in the chain between the demodulator and the frequency-changer valve heaters. In some sets the scale lamp position will be different. R2 will have a low resistance of from 20 to 50 ohms, and must be capable of carrying the full heater current in the event of failure of the scale lamp. A thermistor might be inserted in series with R1, and another might be used in place of the resistor R2.

R3, in series with the rectifier anode, is a surge-limiting resistance of about 50 ohms. The iron-cored choke L1 and the electrolytic capacitors C2, C3, form the h.t. smoothing filter. C1 is the chassis

isolating capacitor. The earthy sign near the top of C1 is a recognized symbol for a connection that goes to chassis, while that at the bottom of it is a recognized symbol for true earth.

Grid bias in an a.c./d.c. receiver is usually obtained by the method of inserting a bias-resistor in series with the cathode lead of each individual valve to chassis, but a suitable negative potential can be obtained by inserting a resistance between L2 and chassis.

Owing to the fact that there is usually little, if any, anode voltage to spare in an a.c./d.c. receiver, it has always been customary to employ a permanent magnet loudspeaker, and to use a low-resistance smoothing choke for L1. In this way the voltage lost in the smoothing circuit is minimized. If energized loudspeakers were used, they had a fairly low resistance field, of the order of 500 ohms; or the resistance was very high and was connected directly across the h.t. circuit, as mentioned earlier.

It will sometimes be found that in place of a standard half-wave rectifier valve, a full-wave type of valve, with dual cathode and two anodes, will be used in an a.c./d.c. receiver. In this case the two anodes will be connected together, putting the two sections in parallel so as to operate as half-wave types. Valves used in this way will be capable of handling twice the rectified current which would be obtained from an ordinary half-wave rectifier with similar characteristics to those of each half of the double valve.

Another type of rectifier that was used in American receivers had a tapping on its heater brought out to a separate pin on the base.

Fig. 57. Where the h.t. smoothing choke is replaced by a resistor, shown here as R1, it is a common practice to feed h.t. to the output valve V1 directly from the rectifier V2 and to pass the h.t. current for the rest of the receiver through a small section of the output transformer T1. The hum thus induced neutralizes the residual hum in the receiver

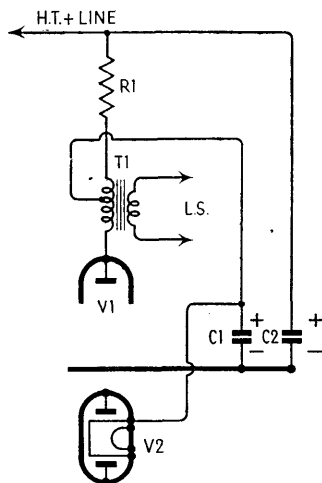

With this valve it is intended that a suitable scale lamp shall be connected across one section of the rectifier heater, and the lamp is therefore not included in the series heater chain in the usual way.

It was mentioned earlier that in some mains receivers the h.t. smoothing choke is replaced by a resistor. This modification is quite common, a resistor of 1,000 or 1,500 ohms being normally employed. Another development is to use a resistor for smoothing, but in addition to pass the receiver h.t. current through a portion of the primary winding of the output transformer in order to remove any residual hum.

The circuit is shown in Fig. 57, where V1 is the output valve and V2 the h.t. rectifier valve in an a.c. or an a.c./d.c. mains receiver. C1 and C2 are the electrolytic smoothing capacitors and R1 is the smoothing resistor. T1 is the output transformer, and it will be seen that h.t. current passes from the cathode of V2 via a tapping on the primary winding of T1 through the upper portion of the primary, and thence through R1 to the h.t. positive line. The h.t. current for V1, of course, passes through the lower portion of the primary of T1 to the anode.

This method is very effective and it helps to keep the cost of the receiver down by eliminating the heavy, bulky, expensive, iron-cored smoothing choke. In passing unsmoothed h.t. current through the transformer winding, hum is actually introduced into the output circuit and by careful design this neutralizes the hum reaching the output circuit by other routes. The earlier stages in the receiver are fed with h.t. that is smoothed by R1 and C2, and because the current they require is comparatively small, resistance-capacitance smoothing can be used for it.

Half-wave rectification in later circuits is usually effected not by a thermionic valve, nor yet by a metal rectifier of the "dry-contact" type mentioned earlier, but by a silicon rectifier. The silicon rectifier has the great advantage that its "forward" resistance is very low, and its leakage resistance in the reverse direction is very high, so very little power is dissipated in it. Consequently it runs cool and is more efficient than other types, particularly the thermionic valve, which not only generates a lot of heat in rectifying the mains current but also dissipates an appreciable amount of power in its heater.

CHAPTER 27

MAINS / BATTERY PORTABLES

One of the most popular types of receiver at one time was the mains/battery portable, which would work from the mains or self-contained dry batteries. When it was first introduced a short time before the second world war, very complicated switching was necessary to change over from mains to battery operation, but in later versions the power circuits became quite simple. Only the power supplies are affected in the change-over, and the general design falls into two categories: the a.c./battery receiver, and the a.c./d.c./battery receiver.

The first, as it operates only from a.c. mains (or batteries), uses a mains transformer, and it is therefore able to supply the filaments of the valves with their rated voltage, usually 1.4V. The filaments are therefore connected in parallel and are supplied with current alternatively from a rectifier with a 1.4V output or from a 1.4V dry cell. Similarly, h.t. current is supplied from a rectifier at about 90V or alternatively from a 90V dry battery.

The second type of receiver, which operates from a.c. or d.c. mains (or batteries), has to use a series-connected system for the valve filaments, like the series heater chain in a mains receiver, and to avoid the need for switching to convert them to parallel connection for battery operation, a 7.5V l.t. battery is used and the valve filaments remain series-connected for battery operation. H.T. current is supplied from the mains via a conventional type of metal rectifier with a large ballast resistor to drop the mains voltage down to about 100V for mains operation; for battery operation a 90V battery is used, as before.

The most popular type of receiver is the one that operates from a.c. or d.c. mains or dry batteries, but the one that operates only from a.c. mains or dry batteries is simpler. A diagram showing the essential features of one of these latter appears in Fig. 58. For mains operation, h.t. current is taken from the large secondary winding on the mains transformer T1, rectified by the metal rectifier

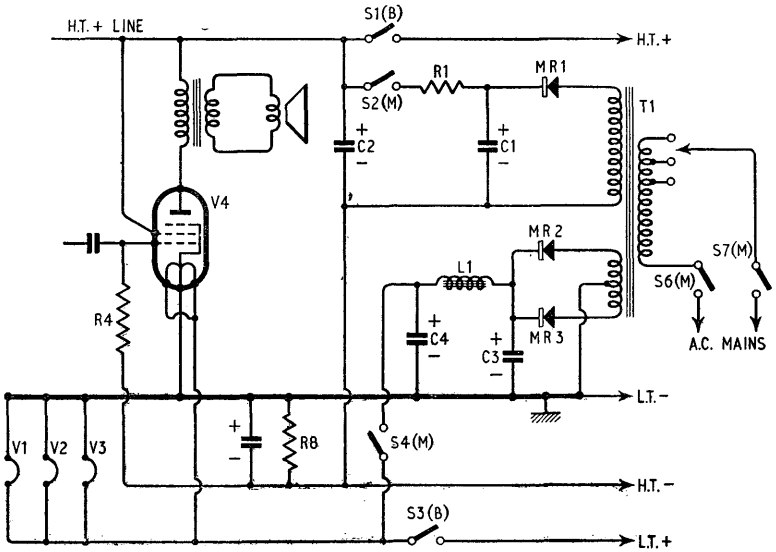

Fig. 58. Circuit diagram of the power supply circuit of a typical a.c. mains/all-dry battery (a.c./a.d.) receiver. The positions of V1, V2 and V3 filaments are shown. The two sections of V4 filament are connected in parallel. (B) switches close for battery operation, and (M) switches for mains. Grid bias for V4 is obtained from the drop along R8

MR1, and smoothed by R1, C1, C2. Filament current is taken from the smaller secondary and rectified by MR2 and MR3, which constitute a full-wave rectifier, because the a.c. ripple is then 100 c/s and is easier to smooth than is a 50 c/s ripple. Smoothing is performed by L1, C3, C4. More care has to be taken with filament smoothing than with h.t. smoothing.

When the control is turned to the "mains" position, the switches with the suffix (M) all close, and those with (B) open. Thus the parallel-connected filaments are connected by S4(M) to L1, and the h.t. positive is connected by S2(M) to R1, while S6(M) and S7(M) close to connect the mains to the transformer primary. S6(M) and S7(M) are of the quick make-and-break type, not of the wafer type, although they are usually ganged with others. Grid bias for the output valve V4 is obtained from the voltage drop along the resistance R8 in series with the negative h.t. lead to chassis.

When the control is turned to the "battery" position, the (M) switches open, cutting off the mains supply, and the (B) switches connect up the batteries in the ordinary manner. Usually the control has three positions, the centre one being marked "off",

and thus the change-over switches operate also as "on/off" switches. Alternatively, S3, S6 and S7 could be mounted on a separate switch unit, which would then be used as the on/off control whether the set was switched to mains or battery. Usually, however, when a separate on/off control is employed, the designer contrives to manage with a 2-pole switch.

The a.c./d.c./a.d. circuit (a.d. is an abbreviation for all-dry batteries) is shown in Fig. 59, where the same reference numbers have been used as far as possible as were used in Fig. 58 to permit a convenient comparison to be made. Switches S1(B) and S2(M)

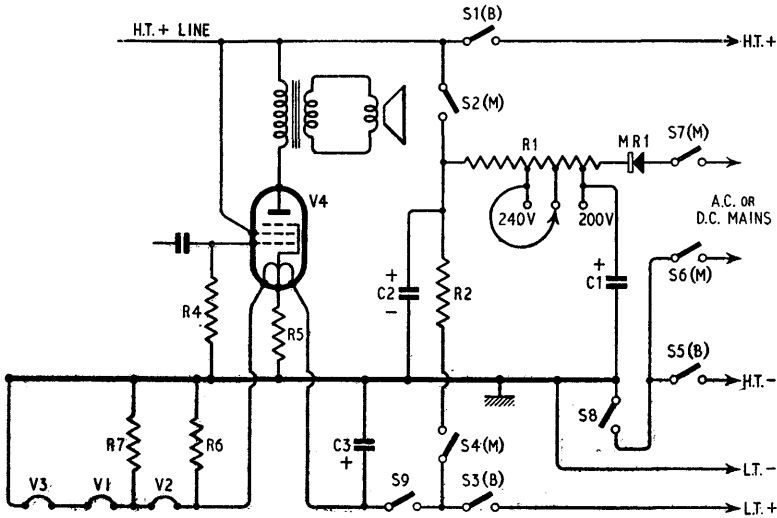

Fig. 59. Diagram of a typical a.c./d.c. mains/all-dry battery (a.c./d.c./a.d.) receiver power supply circuit. The positions of V1, V2 and V3 filaments may usefully be compared with those of Fig. 58, while the two sections of V4 filament are seen to be connected in series. R5, R6 and R7 are h.t. by-pass resistors. S8 and S9 are the separate on/off control switches, which operate for mains and battery

therefore connect up the h.t. supply, while S3(B) and S4(M) connect up the filament supply, and S7(M) and S6(M) connect up the mains. S5(B) is an additional switch that isolates the h.t. battery from the mains when working on mains. Two further additional switches are S8 and S9, which act as on/off switches on battery or mains. They are of the quick make-and-break type, ganged with the wafers carrying the other switches but not actually forming part of them. This is the alternative arrangement of a separate on/off control that was referred to at the end of the last paragraph.

The switching makes the circuit look rather complicated, but if the (M) and (B) markings are followed, the operation is quite clear. The rather unexpected feature of these circuits is that the filament current is taken from the h.t. supply. The rectifier MR1 supplies current from the mains, and the ballast resistance R1, which is adjustable in the same way as in an a.c./d.c. receiver, drops the voltage down to about 100V at C2. R1, C1 and C2 provide the h.t. smoothing, and their d.c. output is divided, going through S2(M) to the h.t. circuit and through R2 and S4(M) to the filament circuit.

Thus the filaments are run by current from the h.t. circuit, taking 50mA (0.05A) in earlier receivers, but only 25mA in later ones. The ballast resistance R2 drops the voltage down to 7.5V, and R2, C3 provide the high degree of smoothing that is necessary in the filament circuit.

The value of C3 is usually between 50 μ F and 250 μ F. Often it is connected to the opposite side of V4 filament because it then has to smooth only the lower voltage of the remaining three valves, but trouble may then be experienced owing to the charging current when switching on, because the metal rectifier comes into action immediately, as it needs no heating-up period before it begins to work, and the charging current flows into C3 via V4 heater. The initial surge current is large, and it can lead to the early failure of V4 filament.

Another interesting feature of the filament circuit in Fig. 59 is the reason for the resistances R5, R6 and R7, some of which are usually present, if not all. They by-pass the h.t. current, which flows through the valves and down to chassis via the filaments. Their values are chosen just exactly to drop the voltage that should exist between their respective filaments and chassis at the calculated anode (and screen) currents of their respective valves. If these resistances were omitted, the h.t. current, small though it is, would over-heat the fragile filaments and shorten their life.

There are many variations of the basic system shown in Fig. 59, but it is still quite representative of the general technique. Often R1, or part of it at least, is on the mains side of the metal rectifier MR1, and there may be more h.t. smoothing than is shown there. MR1 almost always comprises two similar units connected in series, but they constitute only a single rectifier in fact, and two are used simply to provide an adequate voltage rating. A complete a.c./d.c./battery receiver circuit diagram is given on page 132.

Little has been said so far concerning the purely battery-operated receiver, but there is a very good reason for that. In principle its

circuit requirements, with the exception of the form of power supply, are the same as those that are applicable to a.c. mains or a.c./d.c. mains receivers, and practically all the foregoing chapters, with the exception of those dealing with power supplies, apply as much to battery-operated receivers as they do to any other kind. Battery power supplies themselves are so extremely simple that no explanation of them is necessary, and if the (B) battery switches are followed in Figs. 58 and 59, the battery supply circuits then presented are like those of a simple battery-operated receiver, even to the extent of deriving grid bias for the output valve from R8 in Fig. 58.

The principal difference is seen in Fig. 59, which is by far a more common arrangement than is Fig. 58, where the filaments are connected in series with each other, even for battery operation. Often in battery receivers there is no obvious grid bias source for the first three valves, but they obtain it automatically by the voltage drop along their own filaments. If the voltage of the filament is 1.4V, for instance, one end of this filament is 1.4V positive with respect to the other, and the valve manufacturer designs the valve deliberately so that, provided it is connected the right way round, the positive end, being positive with respect to the control grid, acts in the same way as the cathode of a mains valve when it has a cathode bias resistor, as explained earlier. The grid is thus negative with respect to the cathode.

Because the second valve from the chassis end of a series of filaments is 3V positive with respect to chassis, and the third one is 4.5V up, it will often be found that the low-potential end of a control grid circuit is returned not to chassis, where a rather high negative bias would be imposed, but to one side of its own filament, where perhaps 1.4V bias is obtained. Alternatively, where a large bias potential is actually needed, the control grid is deliberately returned to chassis. An output valve can obtain up to some 6V bias by this means.

One other biasing feature in battery receivers, and even in some mains receivers, where a valve of very high impedance is used as an a.f. amplifier, is that derived from what is termed "contact potential". The control grid resistance would be very high, usually 10,000,000 ohms (ten megohms), and it would be connected between grid and the negative side of the filament. When the filament is alight, a minute electron flow takes place, the grid collecting a very small number of electrons which flow through the resistance back to the filament. With such a high resistance, even a small current will produce an appreciable voltage drop. One-tenth of one

microampere would develop one volt. This was referred to previously in Chapter 17.

Particular types of valve have been developed specially for use in all-dry battery receivers, and the same types are used in mains/battery receivers. The frequency changer is a heptode, the i.f. amplifier is an r.f. pentode, the detector is a single-diode inside the envelope of an a.f. pentode, and the output valve is a pentode or a tetrode with a centre-tapped filament so that it can be run in a series circuit with the two halves in series or in a parallel circuit with the two 1.4V sections connected in parallel. As we saw earlier, filament current was reduced to a figure as low as 50 mA for the whole series, and then halved again in a new series of valves. The most commonly used range of valves with 0.025A (25mA) filaments is that comprising the DK96, DF96, DAF96 and the DL96 for V1 to V4 respectively.

Examples of these valves are shown in the complete circuit diagram of a battery receiver on page 133 and another of a representative a.c./d.c./battery receiver on page 132. Two types of frequency changer are seen, that in the mains/battery diagram being of a later type than the other, with separate oscillator anode and screen grid electrodes.

CHAPTER 28

TONE CONTROL CIRCUITS

In preceding chapters we have completed the step-by-step dissection of a simple superheterodyne valved receiver, at any rate as far as the main circuits are concerned. There are, however, a number of subsidiary parts of the main circuit, or additions to it, which must be included in a complete review. The tone control arrangements form one of these and will now be considered.

In the majority of simple receivers, the tone control is arranged merely to reduce the response of the receiver to the higher frequencies, thus attenuating interference whistles, background noises and general "mush". At the same time, the tendency is to make the tone "mellow", and to reduce the intelligibility of speech, and the fidelity of reproduction of certain instruments, such as the violin, which rely largely on high harmonics for their characteristic tone. Such controls must therefore be applied with discretion.

This type of tone control can be simply achieved by placing a capacitor in some part of the circuit where it will by-pass a certain proportion of the higher a.f. signals. It will be appreciated that for a given capacitance, the higher the frequency, the more readily will it be by-passed through the capacitor. Taking a capacitor of $0.01 \mu\text{F}$, for instance, this behaves to an audio frequency of 5,000 c/s as a resistance of 3,000 ohms. To a frequency of 50 c/s, however, it acts as a resistance of 300,000 ohms. Thus the capacitor is 100 times more effective in by-passing a 5,000 c/s current than one of 50 c/s.

In general, receiver designers use the combination of a fixed capacitor in series with a variable resistance as a tone control, so that at the maximum setting of the resistance the capacitor is least effective as a tone control, while at the minimum setting the capacitor is most effective, and the maximum degree of attenuation of the higher frequencies is obtained.

The most usual arrangements of a tone control circuit are shown in Fig. 60, where it will be seen that the control is associated with the

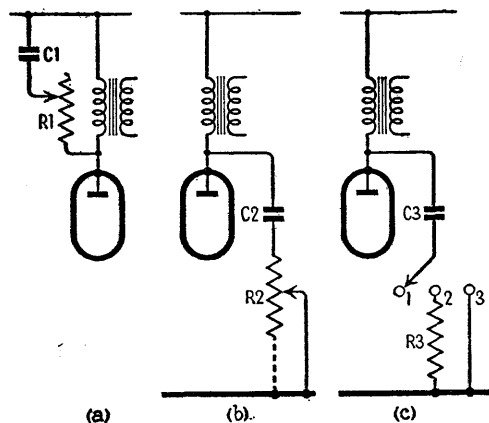

Fig. 60. Three examples of simple variable tone control in the anode circuit of the output valve

anode circuit of the output stage. At (a) the capacitor C1 and variable resistance R1 are connected in series across the primary of the output transformer, while at (b) C2 and R2 are connected from anode to chassis. The effect is the same in each case, and the values of the components are similar. The capacitor usually has a value of 0.01 to 0.05 μF , while the variable resistance usually has a maximum value of 50,000 ohms. Sometimes the free end of the resistance in Fig. 60(b) is connected to chassis.

Both arrangements shown in Fig. 60(a) and (b) provide continuously variable tone control, but in Fig. 60(c) three-point control is used, either with a three-position switch, or a plug and three sockets. C3 is the usual capacitor, and R3 is a fixed resistor of, say, 10,000 or 20,000 ohms. With the switch or plug in position 1, the tone control is not in use, and the tone is "brilliant". In position 2, C3 and R3 are in series from anode to chassis, and the upper register is attenuated to a certain degree. In position 3, C3 is connected direct from anode to chassis, and a higher degree of attenuation of the upper register is secured.

In some cases the tone control arrangements will be found in the anode circuit of the first a.f. valve, the connections being similar to those in Fig. 60(b). It is then unusual for C2 to exceed 0.01 μF , while R2 may be as high as 500,000 ohms maximum.

Tone control which merely involves the reduction of the higher frequencies can also be secured by the use of a resistance-capacitance filter in the grid circuit of the output or first a.f. valve. An example of this is shown in Fig. 61(a). Here C1 (0.002 μF to 0.005 μF) and R1 (500,000 ohms to 2,000,000 ohms) form the tone control. C2 is the usual a.f. coupling capacitor, and R2 is the volume control.

Some receivers employ a simple form of tone compensation which is designed to reduce the upper register progressively as the volume control is turned down. The effect of this is to give an apparent increase in bass response at low volume levels and thus to compensate for the falling off in the bass which always appears to occur under these conditions. The circuit for this is shown in Fig. 61(b), where it will be seen that the volume control R4 is tapped near its lower end. From the tapping are connected R3 and C5 in series to chassis, and typical values are 50,000 ohms for R3 and 0.01 μF for C5.

The tapping on R4 is usually at between one-quarter and one-half of the resistance from the chassis end. With the slider at the top (maximum volume) the compensation is at its minimum, because the whole of the resistance of the volume control down to the tapping is between the filter circuit and the grid of the valve. As the slider is moved down to reduce the volume, R3 and C5 become more effective in cutting the upper register. When the slider is opposite the tapping, the tone compensation is at its maximum. Below this it becomes reduced again, but one does not usually work with the volume control as low as this. It is not desirable to make the tapping too close to the bottom of R4, since the low resistance between the tapping and chassis would practically short-circuit R3 and C5.

Fig. 61(b) also shows another form of tone control. C4 is the normal a.f. coupling capacitor, while C3, in series with it, can be short-circuited by the switch S1. With S1 closed, C4 only is in

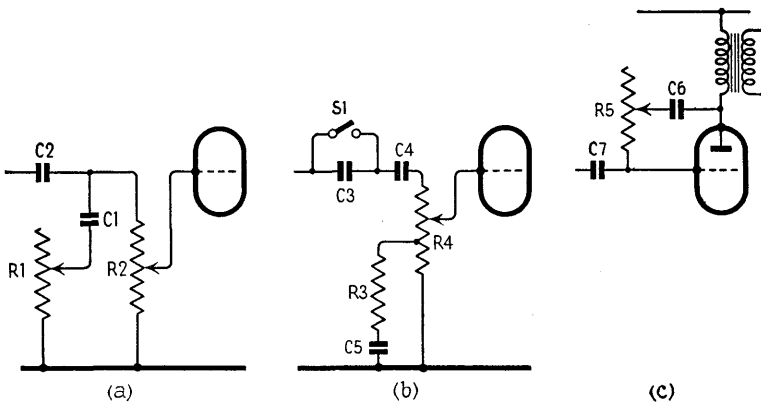

Fig. 61. Three methods of tone control, with the addition at (b) of tone compensation

circuit, and the tone is normal. With S1 open, C3 and C4 in series produce a low-value coupling capacitance, which results in a reduction in the bass response. This, then, is the opposite of the more usual "top cut" tone control, and by a combination of the two methods top cut, bass cut or both can be secured.

Yet another form of tone control is shown in Fig. 61(c). Here the filter C6, R5 is connected between anode and grid of the output valve, C6 being about 0.005 μ F and R5 2,000,000 ohms maximum. With R5 at maximum, the feedback between anode and grid is slight, and the tone is "brilliant". As R5 is reduced, feedback increases, and the tone becomes lower-pitched. R5 and C6 can be replaced by a variable capacitor having a maximum value of 0.0005 μ F.

The tone control circuits described are, of course, the simple ones to be found in the average domestic receiver. A less common method is to achieve tone correction by controlling the band width in the i.f. amplifier. This was done at one time in more elaborate receiver designs, using the variable selectivity methods described in Chapter 12. Some kind of variable a.f. tone control would be used as well, the two controls being ganged together so that when the control was turned to a "deep" position, the selectivity would be sharpened and the a.f. high-note cut at the same time.

In receivers employing negative feedback, which is the subject of the next chapter, tone control is effected by inserting variable elements in the feedback loop which control the ratio of high-note and low-note frequencies fed back. High-note emphasis in the feedback loop reduces the high-note reproduction of the receiver, and low-note emphasis reduces low-note reproduction, which is the opposite to the effect it has in the tone control circuits previously described, with the exception of that in Fig. 61(b) which operates on the negative feedback principle. It emphasizes high-note feedback and thus actually promotes bass boost.

CHAPTER 29

NEGATIVE FEEDBACK

Negative feedback is an arrangement used in the a.f. section of the receiver which can also be pressed into use for tone compensation or control. Normally it is employed to improve the frequency response of the a.f. section of a receiver, and to reduce harmonic distortion. At the same time, the stability of the circuit can be increased, although considerable care has to be taken in designing negative feedback circuits to avoid the possibility of the amplifier bursting into oscillation, because at some frequencies, what was negative may become positive.

The principle used is to feed back from the output to the input a portion of the signal, arranged so as to be in opposite phase to the incoming signal, thus reducing the value of the latter. Now if the a.f. section of the receiver normally amplifies the very low and very high frequencies less than the middle register (as is usually the case), the feedback at these frequencies will be less than that at frequencies in the middle register, so that the incoming signal will be less reduced at the extreme high and low frequency ends, and this will compensate for the deficiencies in the amplifier.

Equally, any pronounced "peak" at a certain frequency in the amplifier will produce a strong feedback signal at that frequency, and this will reduce the input at the frequency concerned, and so tend to neutralize the peak and level up the response. This also tends to reduce instability due to high amplification of signals of certain frequencies. Further, unwanted harmonics, when fed back from the output, tend to be cancelled out in the amplifier.

The advantages of negative feedback are to some extent offset by the fact that the overall gain of the amplifier is reduced by the feedback. This, however, can be easily countered by making arrangements for extra amplification if necessary; often the gain of the a.f. section of the receiver is sufficient to enable negative feedback to be used without increasing the number of stages of amplification. The feedback voltage is usually taken from the anode circuit of

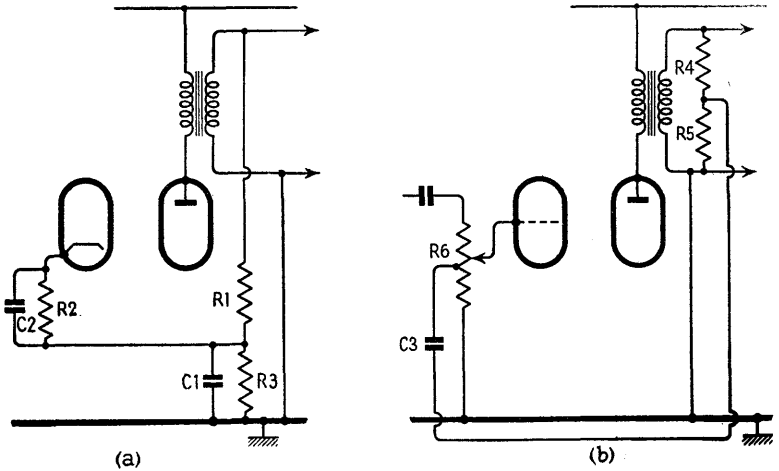

Fig. 62. Two examples of negative feedback whose functions are explained in the text

the output stage to the grid or cathode circuit of this stage or the preceding one, by means of feed resistors and capacitors whose values have to be worked out to give the desired amount of feedback, in the correct phase.

Fig. 62(a) shows one typical feedback circuit. From one side of the output transformer secondary to chassis are connected R1 and R3, with C1 across R3, in series to chassis. R1 may be about 200 ohms, and C1 $4 \mu\text{F}$. The voltage developed across R3, C1 is tapped off and taken to the cathode circuit of the first a.f. valve. R2 is the usual bias resistor, with its by-pass capacitor C2. The value of R3 is small compared with R1, and may be 25 ohms. At 25 ohms one-ninth of the total voltage at the speaker speech coil would appear across R3, but the presence of C1 renders this fraction dependent upon frequency, so that it might be perhaps one-eighth at a low frequency and only, say, one-eightieth at a frequency ten times higher.

Another feedback circuit is shown in Fig. 62(b) which again provides tone compensation. Like R1, R3 in (a), R4, R5 form a potentiometer across the secondary of the output transformer, and a connection is taken from their junction to the tapping on the volume control R6 via the capacitor C3. The feedback effect then varies with the position of the volume control slider as did the tone correction in Fig. 61(b), and of course the frequency response is affected by the different impedance of C3 at different frequencies. In Figs.

61 and 62 the circuit could have been taken from the anode of the output valve instead of the speech coil, but the values would then have been higher and the phasing would have been affected.

Sometimes elaborate frequency discriminating networks are included in the feedback circuit to modify its effect at different frequencies. Thus a parallel choke and resistance in series with the feed will reduce the high note feedback, and will, therefore, increase the amplification of the upper register. It is also possible to decrease the bass feedback, and so boost the lower register. These extra circuits are often cut in or out of action by means of switches, which thus act as tone controls. It is quite common practice to include variable controls in the negative feedback circuit and use them as tone controls. One of the simplest examples of this was seen, in fact, in Fig. 61(c).

Finally, it may be said that a measure of negative feedback can be secured by omitting the by-pass capacitor from the cathode of the output valve to chassis. The cathode bias resistor is then common to both input and output circuits, and a proportion of the total a.f. voltage in the anode-cathode circuit is thus introduced into the cathode-grid circuit, where it provides degeneration.

Some kind of feedback circuit is almost always employed to-day, and often more than one feedback circuit may be incorporated in one receiver (or amplifier). Often two or three parts of an a.f. circuit are linked by feedback paths of different kinds, one path feeding back over only one valve circuit, but another feeding back over perhaps two or three valve stages.

CHAPTER 30

GRAMOPHONE REPRODUCTION

Many radio receivers include provision for the use of a gramophone pick-up when desired. The output from the pick-up, of course, merely needs a.f. amplification in the radio receiver.

The most usual arrangement is to feed the pick-up voltages into the first a.f. stage of the receiver, and to use the radio volume control also for controlling the pick-up output. It is desirable, though not essential, to arrange to switch the pick-up out of circuit when radio reception is desired, and vice versa. The usual circuit is shown in Fig. 63(a). C1 is the a.f. coupling capacitor from the signal diode load, which is connected as usual (but via switch S1) to the top of the volume control R1.

Two terminals are provided for the pick-up connection, one of which goes to chassis and the other to the top of the volume control via switch S2. When S2 is closed, the pick-up is connected in circuit, and at the same time S1 opens, disconnecting C1 and thus muting radio signals. When the set is switched to "radio", S2 opens and S1 closes, enabling radio reception to be obtained in the usual way.

This arrangement is perfectly satisfactory provided that the output from the pick-up is large enough to load the a.f. amplifier sufficiently for the output requirements.

In receivers in which the diode demodulator is directly coupled to a high efficiency output pentode or tetrode, the average pick-up will not always have an adequate output for use in this circuit. In the same way, very high-quality pick-ups, which have a very small output, would need greater amplification than is normally available from an a.f. amplifier and output valve. In such cases extra amplification must be obtained by making some other valve in the receiver act as an a.f. amplifier.

There are various ways in which this can be done, one being to cause the i.f. amplifier valve to act as an a.f. amplifier when the receiver is switched to "gram". In Fig. 63(b), the pick-up is included

in the grid circuit of the i.f. valve, via switch S3. S4 is inserted in the lead to the bottom of the first i.f. transformer secondary to mute radio on gram. R2, in series with the anode circuit of the i.f. valve, is used as the load resistance when the i.f. valve is acting as an a.f. amplifier, but is short-circuited by S5 on radio. From the bottom of R2 a lead goes, via S6, to C2, which is the normal a.f. coupling capacitor. The radio connection to C2, from the signal diode load resistance R3, goes via S7. R4 is the normal volume control.

On radio, S3 is open, S4 closed, S5 closed, S6 open and S7 closed, and the circuit is normal. On gram, S3 is closed, bringing the pick-up into circuit; S4 is open, muting radio; S5 is open, bringing the load resistance R2 into circuit; S6 is closed, passing the amplified a.f. voltages via C2 to R4, and S7 is open.

Another arrangement is shown in Fig. 63(c). Here the screen of the i.f. valve is used as an anode on gram, the valve working as a triode amplifier. The pick-up is connected between the secondary of the first i.f. transformer and chassis, and is short-circuited by S8 when the set is switched to radio. R5 and C3 are the usual screen feed resistance and decoupling capacitor on radio, S9 being closed. On gram, however, S8 opens, putting the pick-up into the grid circuit of the valve, S9 opens and S10 closes, when R5 acts as the "anode" load resistance of the valve, and C3 becomes the coupling capacitor to the volume control.

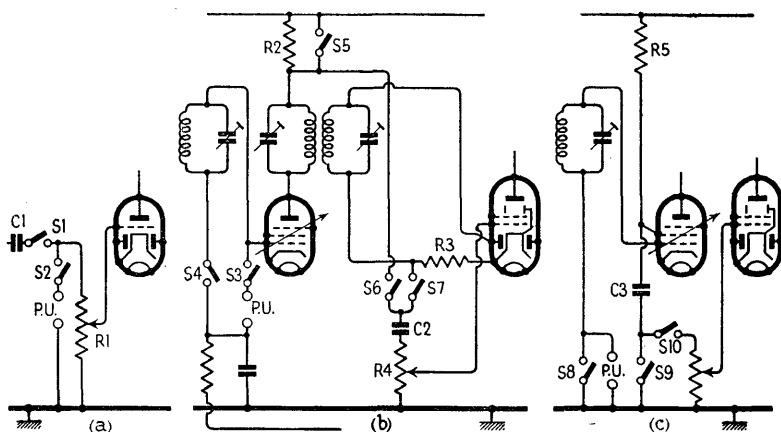

Fig. 63. Connections for gramophone pick-up. The simplest method is shown at (a), but where more gain (amplification) is required the i.f. amplifying valve can be made to amplify the pick-up output as shown at (b) and (c)

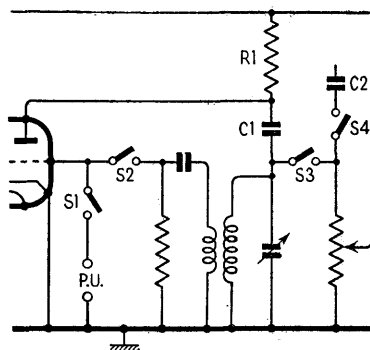

Fig. 64. Additional amplification for the gramophone pick-up can be obtained by using the triode oscillator valve as an a.f. amplifier. A switch on the waveband control, not shown here, automatically disconnects the anode tuning coil when the waveband control is turned to the "gram" position

Finally, the triode oscillator section of a frequency-changer can be used as an a.f. amplifier, as shown in Fig. 64. Here we have a parallel-fed tuned anode oscillator circuit similar to that of Fig. 13(b). The pick-up is connected into the grid circuit of the triode via switch S1, which closes on gram, while S2 opens, muting radio. The anode feed resistance R1 now becomes the load resistance for a.f. amplification, while the anode coupling capacitor C1 becomes an a.f. coupling capacitor. The amplified a.f. voltages are picked up at the bottom of C1 and taken via switch S3 to the top of the volume control. The normal coupling capacitor for radio (C2) is disconnected by switch S4. The tuned anode coil circuit will also be opened on gram by one of the normal wavechange switches, thus isolating the bottom of C1 from chassis. On radio, S1 opens, S2 closes, S3 opens and S4 closes, giving the normal radio circuit. The arrangements described are sometimes altered in detail, but similar principles are usually employed.

In the case of a.c./d.c. receivers a complication arises in that one side of the pick-up, in all the circuits shown except Fig. 63(b), is in direct or indirect electrical contact with the chassis of the receiver. The usual plan to avoid this is to isolate the pick-up by means of a double-wound a.f. transformer, or by fixed capacitors inserted in series with each pick-up lead. These capacitors must, of course, be capable of withstanding the full mains voltage, since the chassis of the set may be at this potential relative to earth potential. If the user came into contact with some metal on the pick-up that was in contact with part of the electrical circuit of the chassis, and as a result of a reversal of the mains plug the chassis were connected to the "live" side of the mains, he could receive a shock that might be dangerous. Where possible all metal parts that are accessible to the user should be connected to a reliable true earth.

CHAPTER 31

SPECIAL TUNING DEVICES

The need for fairly accurate tuning of a superheterodyne receiver, owing to its high degree of selectivity, and the narrow channel spacing allotted to a transmission in the m.w. band or the l.w. band, has resulted in the adoption of some means of visual indication of correct tuning in a large number of cases, and the devices used for this purpose are called tuning indicators.

The earliest types of tuning indicator made use of the change in anode current of one of the valves controlled by the automatic gain control system (usually the i.f. valve) when a station was tuned in. It has been seen that on receipt of a strong signal the a.g.c. system applies an increased negative bias to the controlled valves, thus reducing their gain.

The effect of the increase in bias is to reduce the anode current of the controlled valve, and when a station is accurately tuned this current will be at a minimum. Any form of current indicator will therefore serve as a tuning indicator.

A pointer type of milliammeter is an obvious choice and has been used by a number of receiver manufacturers in earlier days. Its connections are shown in Fig. 65(a), where it will be seen that the instrument is shunted by a by-pass capacitor. Most of the indicators used were simple devices, consisting merely of a coil of wire in the field of which was an iron armature to which the indicating pointer was attached. The d.c. resistance of the indicator winding was usually of the order of 2,000 ohms, but its impedance was, of course, high, and the r.f. and i.f. by-pass capacitor C1 was therefore necessary.

Another form of tuning indicator which obtained a measure of popularity was the "dimming lamp" type, so called because the effect of tuning in a station was to cause a pilot lamp to become less bright, the position of minimum brightness being the correct tuning position. The arrangement of this type of indicator is shown in Fig. 65(b), and it was connected in the anode circuit of the i.f. valve.

L1 and L2 were two chokes (or, more accurately, reactors) wound on the same iron core, and in fact they constituted a magnetic amplifier. L1 (by-passed by C2) was in series with the i.f. valve anode circuit, while L2, in series with an indicator lamp, was connected to a suitable source of a.c. which served to light the lamp. The heater secondary of the mains transformer could be used for this, or a separate secondary winding might be provided.

When the set was not tuned to a station the a.g.c. bias was low and the anode current of the i.f. valve was at maximum. The current flowed through L1 and magnetized the common core of L1, L2. The effect of this was to reduce the impedance of L2, and under these conditions matters were arranged so that the lamp glowed brightly.

When a station was tuned in, the a.g.c. bias increased, the anode current of the i.f. valve was reduced, L1 magnetized the common core to a smaller extent, so that the impedance of L2 increased, and, being in series with the lamp circuit, it caused the lamp to dim. At the correct tuning point the lamp was at its minimum brightness.

A third form of tuning indicator, shown at Fig. 65(c), is of the neon tube variety. It is in a simple form known as the "button" type, and it glows dimly when no signal is being received, but it glows brightly when a station is tuned in. It operates from the anode voltage of one of the a.g.c.-controlled valves via a feed resistance R2. The cathode of the indicator is connected to chassis. Tappings are usually arranged on R1, the anode decoupling resistance of

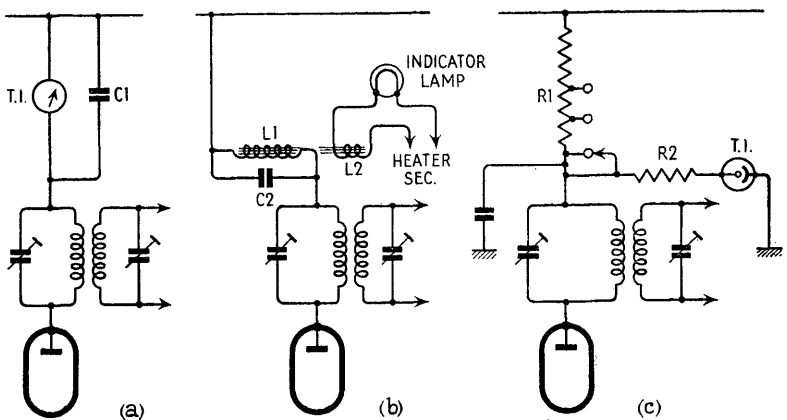

Fig. 65. Three old types of tuning indicator. At (a) is a moving-iron meter instrument; at (b) a "dimming lamp" indicator; at (c) a button-type neon indicator

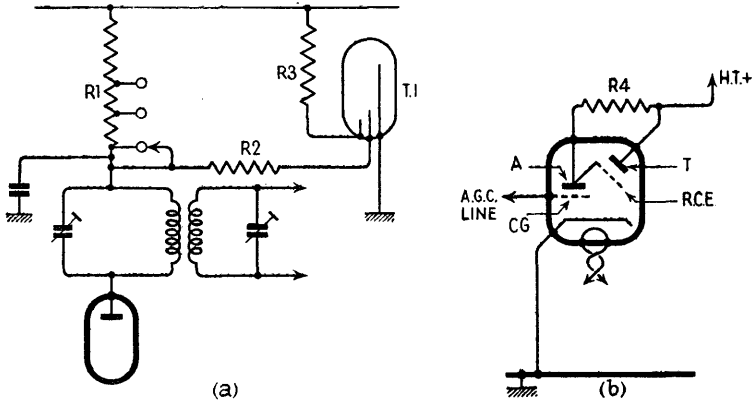

Fig. 66. Two further tuning indicators. The "variable column" neon tube shown at (a) was used at one time, but to-day the cathode ray, or "magic eye", tuning indicator shown at (b) is used almost exclusively

the controlled valve, for adjusting the neon indicator to its optimum setting.

A more elaborate type of neon indicator, shown at Fig. 66(a), is of the tubular type, in which a column of light is produced, the length of the column varying with the applied voltage. As before, the anode voltage of one of the a.g.c.-controlled valves is used to operate the device. The cathode is a rod running the length of the tube, and it is connected to chassis. The anode is fed via resistance R2, and R1 can be adjusted for optimum operation of the tube. A third electrode, known as the priming electrode, is fed from the h.t. positive line via a high resistance R3.

Different connections for the priming electrode and the cathode may be used. Thus the cathode may be fed with about 100 volts positive, while the priming electrode is taken to chassis via a resistance.

All the foregoing tuning indicators are more or less of historic interest only. The most common type to-day is the cathode-ray type of tuning indicator, sometimes known as the "magic eye". This is almost exclusively used at the present time, since it can be made to have a high sensitivity, enabling it to indicate the tuning points of weak stations, as well as strong ones. The usual circuit for this type of indicator is shown in Fig. 66(b). The indicator actually consists of a triode amplifier and a miniature cathode-ray device in the same envelope, the screen of the c.r. section being visible through the end of the tube. It has the usual heater/cathode assembly, and electrons from the cathode strike the target anode (T)

which is maintained at the full anode voltage of the receiver. This produces a greenish glow on the target.

Between the cathode and the target, however, is a ray control electrode (r.c.e.), which is connected internally to the anode of the triode amplifier (A), and therefore takes the same voltage as the anode. This ray control electrode produces a shadow on the target, the angle of the shadow depending on the voltage of the electrode. With a low voltage a wide shadow is produced, and vice versa. The shadow is sharply defined and is very sensitive to voltage changes.

In use the control grid of the triode section is connected to a point in the receiver where the negative voltage varies according to the signal. For instance, the a.g.c. line can be used for this purpose, or the signal diode circuit can be employed. Assuming the a.g.c. line is used, no signal means that there is zero voltage on the a.g.c. line, and therefore no bias on the control grid of the indicator. This means a high anode current, which since the anode is fed via a high resistance R4 (about 1 megohm), produces a low anode voltage, which is applied to the ray control electrode and produces a wide shadow angle.

As a station is tuned in, the control grid becomes negatively biased, reducing the anode current, increasing the anode voltage and the ray control voltage, and reducing the shadow angle. On a strong signal the shadow may disappear altogether, and overlapping of the edges of the glow may occur, but this is usually avoided in the design as far as possible.

A dual type of indicator is also available, with one section sensitive, for weak signals, and the other less sensitive, for strong signals. It should be pointed out that the cathode-ray type of tuning indicator could be used on any set, whether provided with a.g.c. or not, since it merely needs the signal to produce a certain change in voltage in some part of the receiver. An anode bend detector, for instance, fulfils the requirements in its anode or cathode circuit. It is exceptional, of course, to find a receiver that does not use a.g.c.

BAND-SPREAD TUNING

One of the difficulties that are found in trying to tune short-wave transmissions in domestic receivers, if the same method of tuning is used as is employed on the m.w. and l.w. bands, is that the stations appear to be crammed together, the cursor showing only a very small movement as the tuning control is carefully tuned, passing several stations yet without being able to select one of them. This results from merely adding, say, a third band to the existing m.w.

and l.w. bands by introducing a third set of coils which are tuned by the same gang capacitor. The size of the capacitor is too great in comparison with the inductance of the tuning coils.

Whether there is one short-wave band or more, each band covers a wide wavelength or frequency band. Now the distribution of short-wave broadcasting stations is such that they are located in a number of narrow bands, and between these bands few stations of entertainment value are to be found. For instance, in the 16–50 metre band (which is the range usually covered by a single band), the actual s.w. broadcasting bands are around 16m, 19m, 25m, 31m, 41m and 49m. As can be seen, there are appreciable gaps between successive groups of stations, which are practically useless, yet there may be as many as 20 or 30 stations crowded together in perhaps one $\frac{1}{2}$ -in. section of the scale.

The solution to the tuning problem is to take each one of the s.w. bands separately and to spread it out over the whole tuning scale. In these circumstances, stations which were formerly crowded together in small portions of the tuning scale become well separated, and can be tuned in as readily and easily as stations in the ordinary medium wave or long wave bands. The popular name given to this arrangement is "band-spreading".

Receivers using the band-spread technique may have up to eight "band-spread" s.w. ranges, one for each of the important groups of stations from 16m to 49m. On the tuning scales of such receivers individual stations can be accurately marked, which was not possible with sets covering the whole s.w. range in one or two bands.

The original method of securing band-spread tuning was partly mechanical, in that only one tuning coil in each stage was used, with the normal gang capacitor, but with a small variable capacitor in parallel with it for fine tuning. To secure band-spreading the gang capacitor was rotated until it reached certain pre-determined positions in the middle of each of the "band-spread" ranges, and the fine tuning capacitor was then used for the actual selection of stations. The main gang capacitor was located in the correct position for each band by a mechanical stop or "click" arrangement. This, while simple, was not entirely satisfactory, since a slight change in the main capacitor position, due to wear in the "click" mechanism, might easily throw the tuning right off the required band.

The more modern methods of band-spreading are electrical in operation, and vary somewhat from set to set. Broadly speaking, a separate tuning coil is used for each of the band-spread ranges, the normal tuning capacitor is disconnected, and one of smaller maximum capacitance (also included in the ganged unit) is employed.

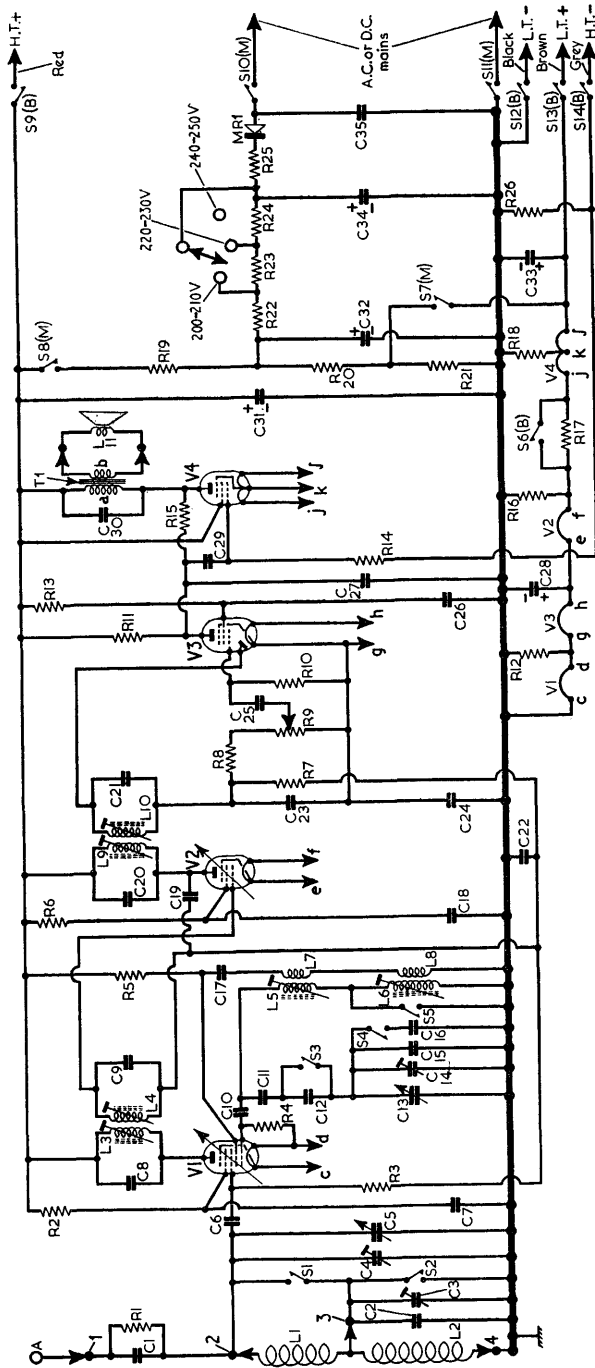

Complete circuit diagram of a typical portable battery receiver of the type that will operate from a.c. or d.c. mains or self-contained dry batteries. Many of the features described in the text will be recognized here, including the resistors R12, R16 and R18 which by-pass the h.t. current past the filaments. The (B) switches close for battery operation, and (M) switches for mains. On mains operation the rectifier MR1 supplies current both to the h.t. circuit and the heater circuit. On battery operation h.t. is supplied by a 90V h.t. battery, while the filaments, which remain connected in series, are supplied from a 7-5V battery. A small frame aerial is used here, but ferrite rod aerials are now more common.

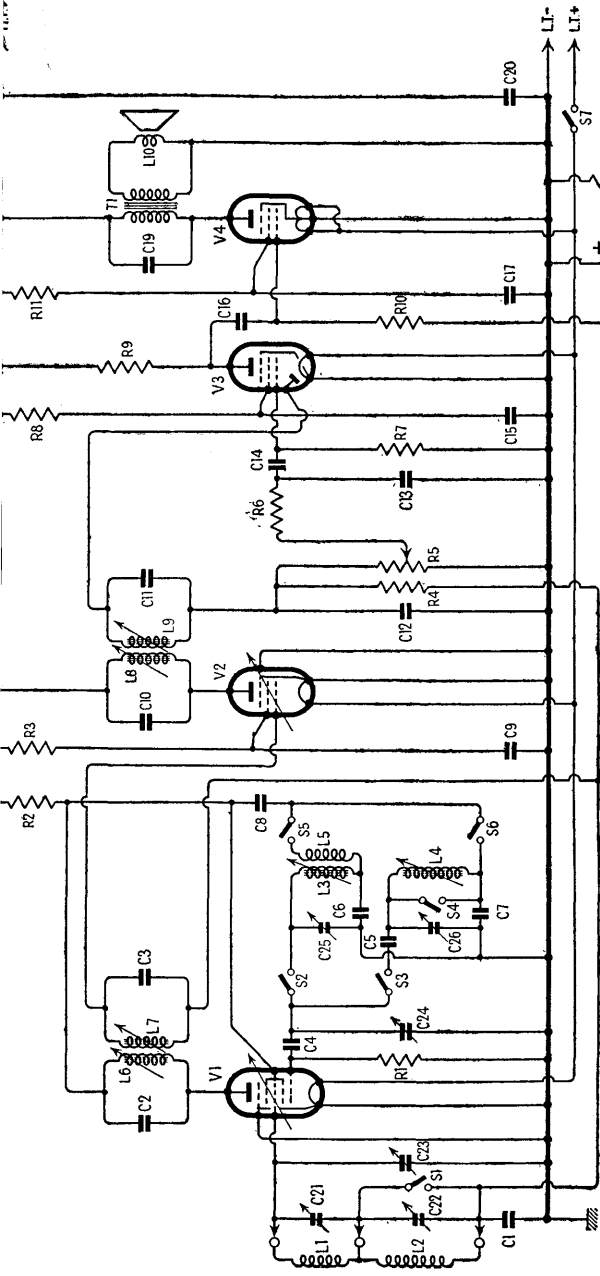

Complete circuit of a simple "all-dry" battery receiver. Tuned frame aerial input by L1, C23 (m.w.) or L1, L2, C23 (l.w.) precedes a heptode valve (V1), operating as frequency-changer. Oscillator grid coils L3 (m.w.) or L4 (l.w.) are tuned by C24, with parallel trimming by C25 (m.w.), C26 (l.w.), and series tracking by C6 (m.w.), C5, C7 (l.w.). Second valve (V2) is a variable- μ r.f. pentode operating as intermediate frequency amplifier with tuned-transformer couplings, C2, L6, L7, C3 and C10, L8, L9, C11. Diode second detector is part of single diode pentode valve (V3). Audio frequency component in rectified output is developed across manual volume control R5, which is the diode load resistor, and passed via R6, a.f. coupling capacitor C14 and C.G. resistor R7, to grid of pentode section, which operates as a.f. amplifier. I.F. filtering by C12, R6, C13 in diode circuit. The d.c. potential developed across R5 is tapped off and fed back through a decoupling circuit R4, C1 as automatic g.b. to f.c. and i.f. valves. Resistance-capacitance coupling by R9, C16, R10 between V3 pentode and pentode output valve (V4), whose twin filament sections are wired in parallel. G.B. potential for V4 is obtained from the drop across R12 in the h.t. negative lead to chassis. Grid bias for V3 is obtained from "contact potential" developed along R7. In modern designs L1, L2 would be wound on the ends of a long rod of ferrite material.

One type of circuit used is shown in Fig. 67. Here only three band-spread ranges are shown for simplicity, and one normal range (for example, the m.w. band). The circuit has also been simplified by the removal of components not essential to the explanation, and only the aerial input section of the circuit is shown. Similar arrangements are provided for the oscillator circuit.

In Fig. 67 L1, L3 and L5 are the aerial coupling coils for the band-spread tuning coils L2, L4, L6. L7 is the coupling coil for the m.w. tuning coil L8. C1 is the normal aerial tuning section of the ganged tuning capacitor, while C2 is the smaller band-spread tuning capacitor included in the gang, and would probably be controlled by a concentric tuning spindle running through the middle of the main spindle. This is repeated in the oscillator circuit.

When the set is used on the m.w. band, the band switch closes S10, S12 and S13, all the band-spread switches (S1-S6) being open. S7, S8 and S9 are closed, to short-circuit the coils L2, L4, L6. When the set is switched to the first band-spread range, S10, S12 and S13 open, the latter switch disconnecting the normal tuning capacitor C1. In addition, S1 and S4 close, and S7 opens, while S11 closes, shorting the m.w. tuning coil. The other switches remain as on m.w.

Switching to the second band-spread range opens S1 and S4, closes S7, closes S2 and S5, and opens S8, the other switches

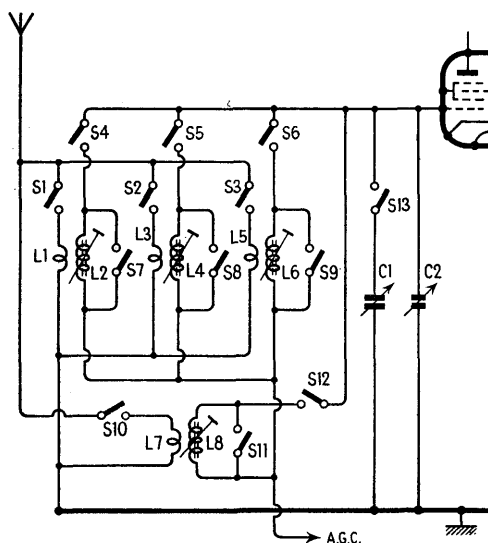
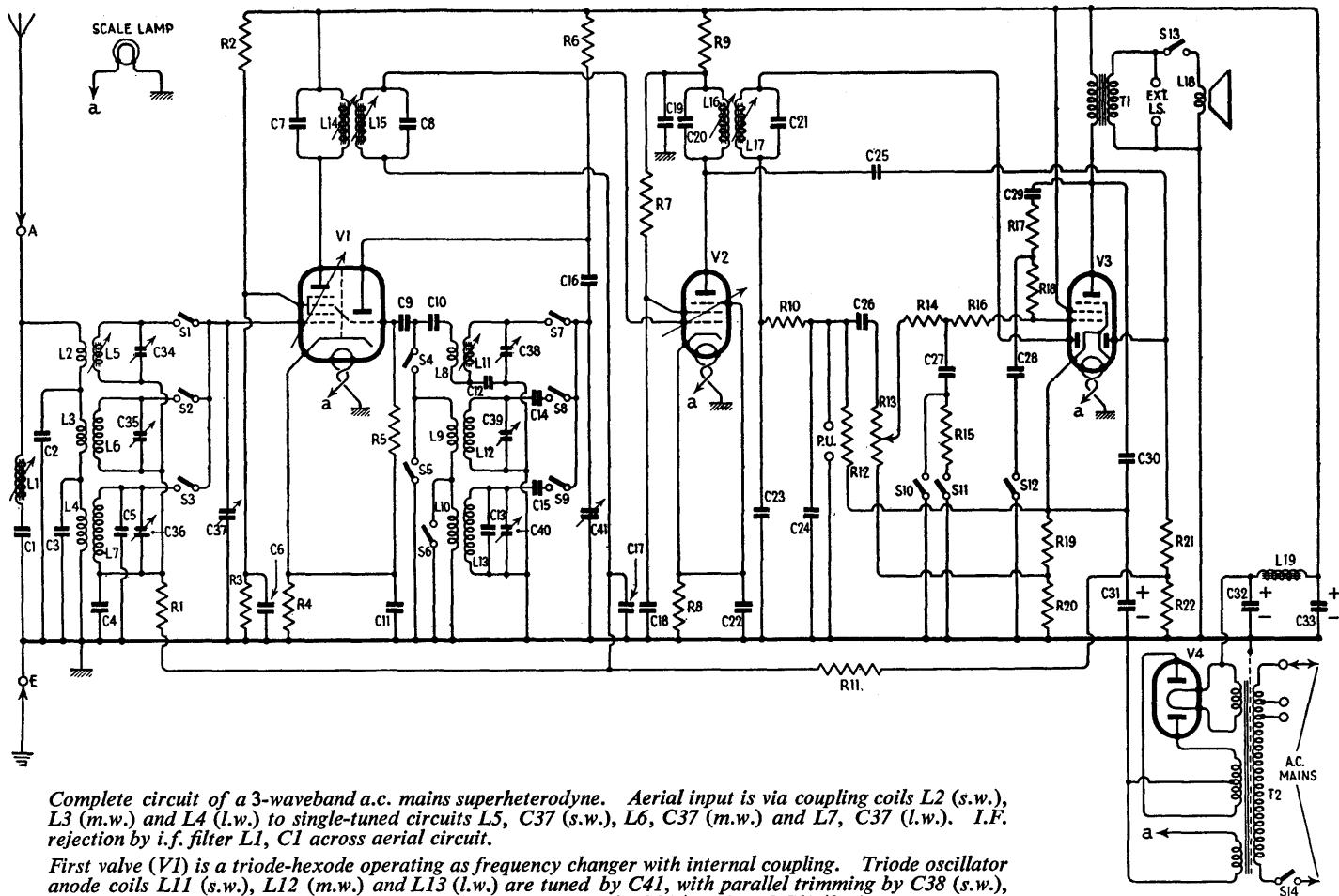

Fig. 67. Simplified circuit of a multi-band aerial input arrangement for band-spread tuning on short waves. Three short-wave band-spread circuits are shown above, with a medium-wave circuit below them. The cores shown in the coils may be made of ferrite material (which increases the inductance) or some non-ferrous metal (which reduces the inductance)



Complete circuit of a 3-waveband a.c. mains superheterodyne. Aerial input is via coupling coils L2 (s.w.), L3 (m.w.) and L4 (l.w.) to single-tuned circuits L5, C37 (s.w.), L6, C37 (m.w.) and L7, C37 (l.w.). I.F. rejection by i.f. filter L1, C1 across aerial circuit.

First valve (V1) is a triode-hexode operating as frequency changer with internal coupling. Triode oscillator anode coils L11 (s.w.), L12 (m.w.) and L13 (l.w.) are tuned by C41, with parallel trimming by C38 (s.w.), C39 (m.w.) and C13, C40 (l.w.) and series tracking by C12 (s.w.), C14 (m.w.) and C15 (l.w.)

Inductive reaction coupling to c.g. by coils L8 (s.w.), L9 (m.w.) and L10 (l.w.), with additional capacitive coupling on s.w. due to the common impedance of tracker C12.

Second valve (V2) is a variable-mu r.f. pentode operating as i.f. amplifier with tuned transformer couplings.

Diode second detector is part of double diode pentode output valve (V3). Audio frequency component in rectified output is developed across load resistor R12 and passed via a.f. coupling capacitor C26, manual volume control R13, and tone control network resistors R14, R16 to c.g. of pentode section. I.F. filtering in diode anode circuit by C23, R10, C24.

Three-position tone control in pentode circuit, via switches S10-S12, by R14, R15, R16 and C27, C28 in conjunction with the voltage negative feed-back resistors R17, R18.

Second diode of V3, fed from V2 anode via C25, provides d.c. potential which is used for a.g.c. purposes.

Delay voltage, together with g.b. for pentode section, is obtained from the drop along R19, R20 in V3 cathode lead to chassis.

H.T. rectification by V4, fed from mains transformer T2, with smoothing by L19, C32 and C33.

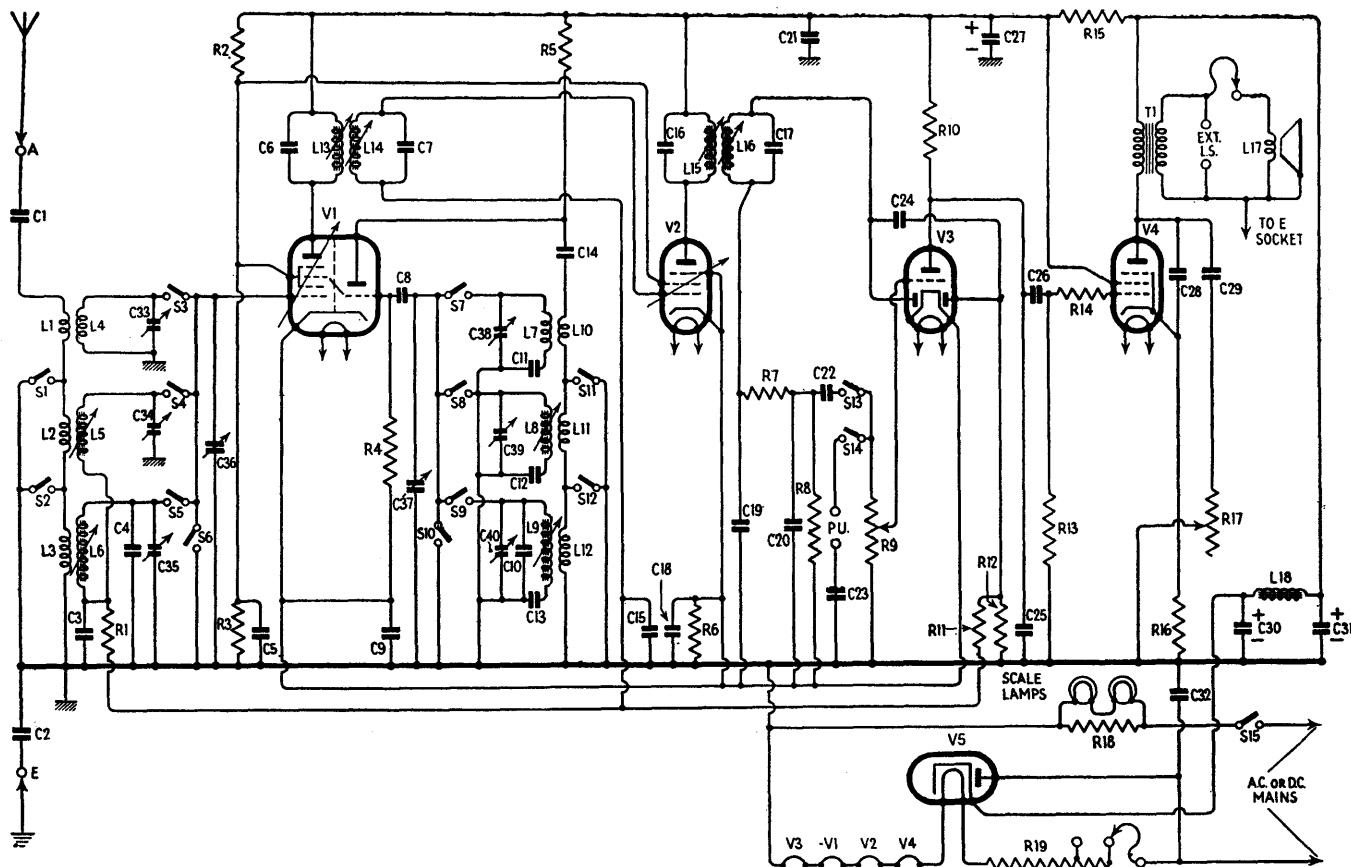

Complete circuit of a 3-waveband a.c./d.c. mains superheterodyne. Aerial input to single-tuned circuits, which precede a triode hexode valve (V1), operating as frequency changer with internal coupling.

Triode oscillator grid coils L7 (s.w.), L8 (m.w.) and L9 (l.w.) are tuned by C37. Parallel trimming by C38 (s.w.), C39 (m.w.) and C40 (l.w.); series tracking by C11 (s.w.), C12 (m.w.) and C13 (l.w.). Reaction coupling by coils L10 (s.w.), L11 (m.w.) and L12 (l.w.).

Second valve (V2) is a variable- μ r.f. pentode operating as intermediate frequency amplifier.

Diode second detector is part of double diode triode valve (V3). Audio frequency component in rectified output is developed across load resistor R8 and passed via a.f. coupling capacitor C22, switch S13 and manual volume control R9 to control grid.

Second diode of V3, fed from L16 via C24, provides d.c. potentials which are developed across load resistor R12 and fed back through de-coupling circuits as g.b. to f.c. (except on s.w.) and i.f. valves, giving automatic gain control. Delay voltage, together with fixed g.b. for V1, V2 and V3, is obtained from the drop along R6, which is common to the cathode circuits of the three valves.

Resistance-capacitance coupling by R10, C26 and R13, via grid stopper R14, between V3 triode and pentode output valve (V4). When the set is used on a.c. mains, h.t. rectification is by V5. Smoothing by L18, C30 and C31.

Fig. 68. Basic arrangement of a band-spread circuit which uses the normal tuning capacitor C_1 , modified in value by C_2 and C_3

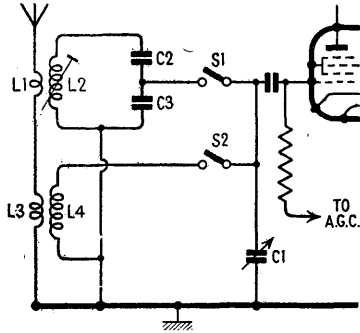

remaining as for the first band-spread range. Similar switching occurs when the third band-spread range is brought into use.

Another system in use is still to employ separate tuning coils for each band-spread range, but to connect the normal tuning capacitor in the ganged unit to the appropriate coil via a combination of fixed capacitors which reduce the effective value of the tuning capacitor to the required degree.

An outline of such a circuit is demonstrated in Fig. 68, showing one set of band-spread coils, L_1 , L_2 and the m.w. coils L_3 , L_4 . On the m.w. band S_2 is closed and S_1 open, connecting the normal tuning capacitor C_1 across L_4 . On the band-spread range S_2 opens and S_1 closes connecting C_1 across L_2 , via C_2 and C_3 , two fixed capacitors. C_3 is then effectively in parallel with C_1 , while C_2 is in series with them both.

Variations of these circuits are common, but broadly speaking the principles are the same, a separate coil being used for each band, and a large rotation of the tuning control effecting only a small change of capacitance. In some of the simpler sets, incidentally, the band-spread aerial circuits may be fixed-tuned to a point in the middle of the band concerned, only the oscillator circuits employing variable tuning.

AUTOMATIC TUNING

Press-button tuning for the automatic selection of a number of stations has been in use for many years, and in fact it is very much less popular now than it was before the second world war. The circuits used in press-button receivers do not differ from those already described, except that special switching arrangements are employed to bring the tuned circuits associated with each pre-set station into action. The switching is performed by pressing a

button, or depressing a key, and operation of any button or key releases that which was previously operated.

In general, the pre-tuning of the aerial circuit is achieved by the use of a separate pre-set capacitor for each station, this capacitor being switched in parallel with the normal tuning coil of the appropriate waveband when the button allocated to the station is pressed. At the same time, the normal variable tuning capacitor is disconnected by the press-button switching.

In the oscillator circuit, however, it is customary to employ separate iron dust-cored coils for each pre-tuned station, in combination with fixed tuning capacitors, since this gives a greater stability of tuning in the oscillator circuit, where any appreciable tuning drift cannot be tolerated.

Consequently, the switching is arranged so that on depressing any station button the normal manual oscillator tuning circuit is disconnected, and the complete oscillator pre-tuned circuit for the station concerned is substituted.

Each station press-button operates all the switches in each of the tuned circuits associated with the tuning arrangements for the station concerned. The switch units are therefore of a complicated nature, and the resulting circuit diagram is often rather difficult to follow without an explanation of which switches close when the button is pressed, and which open.

Other methods of press-button tuning are of a mechanical nature, and do not affect the circuit at all. In these cases the pressing of the button merely rotates the gang tuning capacitor to a pre-determined position to receive the station required. In more elaborate sets, which had a measure of popularity before the war, rotation of the gang capacitor was carried out by a small electric motor, set into motion when a button was pressed, and stopped by a break in a contact, which was adjustable in order to select the station required.

CHAPTER 32

F.M. RECEIVERS

There is some confusion in the minds of many people as to the meanings of the various terms associated with frequency modulated transmissions. They are referred to by the abbreviation f.m., they are sometimes called v.h.f. radio transmissions, and their frequency range falls in Band II. To those who understand the meaning of the term frequency modulation the abbreviation is at once obvious, and many people believe that this is the best way to refer to the system, so that we get f.m. radio, f.m. transmissions, f.m. aerials and f.m. receivers. Others prefer the term v.h.f. radio, distinguished from m.w. and l.w. radio by the term v.h.f., which means a very high frequency. Band II, in which v.h.f. radio frequencies lie, is one of several v.h.f. bands. Its range is 85–100 Mc/s.

As a result of this confusion, references will be found in sales literature to v.h.f./f.m. receivers, principally because the sales departments are not sure which term the reader will understand. It is unfortunate that the two terms have become current, and really there is no justification for it. F.M. is quite distinctive, and it refers to the essential feature in which the system differs from the a.m., or amplitude modulated, system.

In this book the two systems are referred to as a.m. and f.m. All the preceding chapters have dealt with a.m., and for the next four chapters we shall be dealing with f.m. In conformity with the rest of the book, only the circuitry will be described, not the system itself, except where necessary to make an explanation clear, and for readers who would like to read an explanation of the theory of the f.m. system, as distinct from a.m., here are two suitable books: *Principles of Frequency Modulation*, by B. S. Camies, which is published by Iliffe, and *F.M. Radio Servicing Handbook*, by Gordon J. King, which is published by Odhams.

There are only three features associated with f.m. in which it differs radically from a.m., but two of these are differences in principle. One is that the amplitude of the carrier does not change

with modulation, while its frequency does, and this entails a much greater band-width than is necessary for a.m. transmissions; another is that to deal with such a signal of varying frequency instead of varying amplitude, a special kind of detector circuit, called a "discriminator", is necessary; and a third feature is that the transmissions take place at v.h.f. (very high frequency range), which introduces special techniques not encountered in a.m. radio on the normal l.w., m.w., and s.w. bands, including aerials and feeders of the type used with television receivers. In this region, too, bands are referred to by their frequency in megacycles per second (Mc/s) instead of in wavelengths.

The three f.m. transmissions (Home, Light and Third) for a given area are radiated from a single aerial system, and although their carrier frequencies are different for different areas, those from a given transmitter usually have the same relationship, being separated by 2.2 Mc/s. For instance, those for the London and South East England area, which are radiated from the Wrotham transmitter, have the following frequencies: Light, 89.1 Mc/s; Third, 91.3 Mc/s; Home, 93.5 Mc/s; and at most other transmitters the same order is maintained. There are one or two divergences from the standard pattern where four frequencies are used, but otherwise the same sequence is followed for all areas.

Apart from the greatly increased band-width that is required and the high frequencies involved, the aerial input circuit, the frequency changer and the i.f. amplifier are no different in principle from similar stages in a.m. circuits, but the v.h.f. band in which the signal is transmitted introduces features which make the aerial and frequency changer circuits look different, while the band-width necessitates a high intermediate frequency in the i.f. amplifier.

In addition to the different circuitry, it is necessary in v.h.f. receivers to use an r.f. amplifier at signal frequency, which in an a.m. receiver in these days would be a rare luxury. Furthermore, the standard type of a.m. frequency changer is unsuitable for v.h.f. receivers, and a triode is used as a self-oscillating mixer for frequency changing.

If we start by considering the aerial circuit, as we did with a.m. receivers, we meet a special feature of the circuit right away. Whereas in a.m. receivers the aerial consists of a wire called the "lead in" coming down from another piece of wire of indeterminate length called the aerial, in f.m. we have a twin cable of some special type coming down from an aerial made of two rods of fairly well defined length (called a dipole); or from a loop-shaped aerial (called a folded dipole).

The principal difference between a dipole and an a.m. aerial is that the dipole is very short and rigid, and is of such dimensions that it resonates at the signal frequency. In other words, it forms a tuned circuit of its own. Connections to it therefore must be made to match it, so as not to disturb its tuning, and they are almost always made to the middle of it.

The connections to the aerial represent a specified impedance, and the cable connected to it must have a similar "characteristic" impedance. The impedance at the aerial terminals is about 75 ohms in a dipole, and 300 ohms in a folded dipole. The cable (or "feeder", as it is usually called) connecting it to the receiver will be either a flat twin pair (called balanced twin feeder) or a concentric pair (called co-axial feeder) for the dipole; or a twin pair quite widely spaced for a folded dipole.

There is an important difference between a flat twin pair, whether it be 75 ohms or 300 ohms, and a co-axial pair, because one side of the co-axial feeder is connected directly to chassis, or earth, and neither side of the flat twin pair is. Co-axial cable consists of a single conductor (the inner) enclosed in, but insulated from, a tubular conductor (the outer), and it is the outer which is earthed.

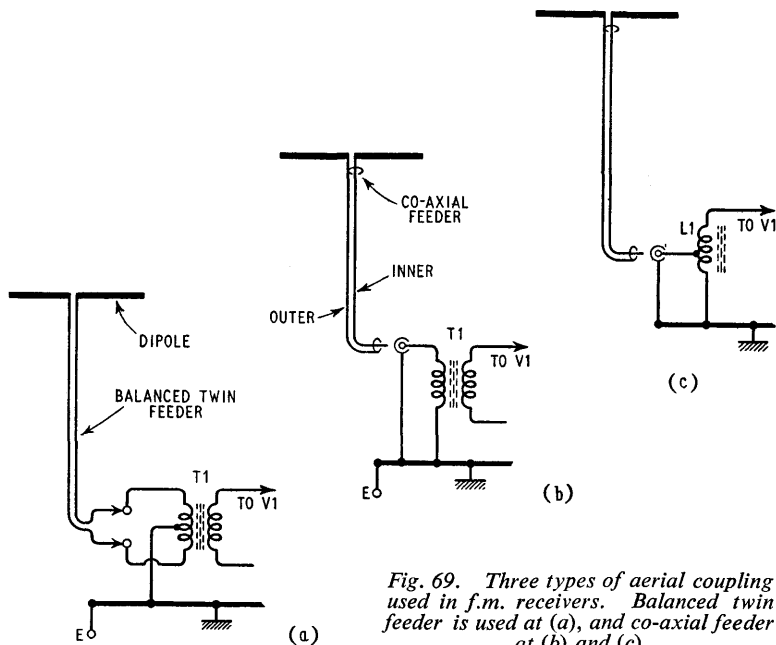

Fig. 69. Three types of aerial coupling used in f.m. receivers. Balanced twin feeder is used at (a), and co-axial feeder at (b) and (c)

The two arrangements are shown in the diagrams in Fig. 69. The aerial is represented as a horizontal dipole, because all f.m. transmissions are horizontally polarized. At (a) it is connected to the receiver by balanced twin feeder, and for that reason a coupling transformer is necessary because the two conductors must be symmetrically disposed either side of chassis potential. This is achieved by connecting them to the ends of a centre-tapped winding which forms the primary of the transformer T1. If the feeder is of the low impedance type (75 ohms), as it nearly always is, there will be noticeably fewer turns on the primary than on the secondary.

At (b) a transformer T1 is again used, but this time with a co-axial feeder. In diagrams, co-axial cable is indicated by drawing two lines to represent the inner and outer conductors, but little loops are drawn at the ends to represent the enclosure of the inner by the outer. The inner goes through the centre of the loops, and the outer is actually joined to them. It is usual in diagrams to indicate the special sockets that are made to receive co-axial cables by similar loops, but in the centre of the loop is a smaller loop, representing the female side of the inner conductor's connection.

At (b), therefore, it can be seen that when the feeder is connected, the inner goes to the top of the primary of T1, and the outer goes to chassis. Again, because co-axial is always low impedance, T1 primary will have fewer turns than the secondary. This is necessary in order to match the impedance of the feeder, which already is matched to the aerial, to the input impedance of the first valve circuit. When co-axial feeder is used it can be done more simply by tapping down the connection of the inner conductor directly on the coil in the valve circuit, as shown at (c). This cannot be done

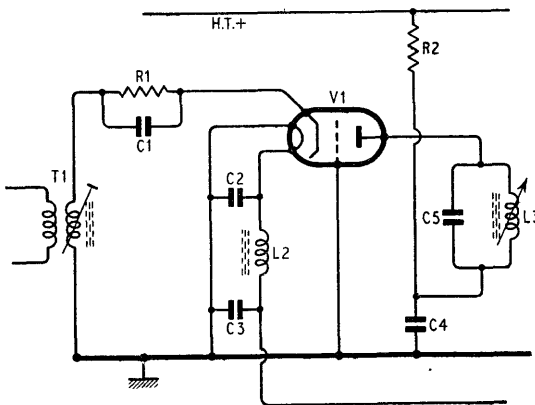

Fig. 70. Common form of aerial input circuit to the first valve V1 in an f.m. receiver. T1 secondary is pre-set to the middle of the tuning range of the receiver. V1 is an earthed-grid triode r.f. amplifier

with balanced twin, because it cannot be so connected and remain balanced about chassis potential.

The transformer secondary or coil L1 is not usually connected to the control grid of the first valve, which acts as an r.f. amplifier. In these rather specialized circuits, it is usual to employ a special type of triode valve as the r.f. amplifier, and its control grid is connected directly to chassis. The input signal is then applied to its cathode, as shown in Fig. 70.

This diagram shows the complete circuit of the most common type of r.f. amplifier in f.m. receivers. R1 is the cathode bias resistor, by-passed by C1. These are shown connected between the cathode and T1 secondary, but they are often connected between the coil and chassis. Earthing the grid of the valve helps to stabilize the amplifier, but it also inserts a fairly good screen between the anode and the cathode, thus reducing radiation from the oscillator circuit that follows. At these high frequencies it is difficult to screen off such radiation efficiently, but this is one means of reducing it and preventing it from reaching the aerial.

The reason for using a triode is that it is less "noisy" than a pentode, and in any case the full advantage of the amplification of a pentode cannot be taken at such high frequencies. Some manufacturers do use pentodes, however, but in a diagram they look very much the same as they do in a.m. circuits, and there is therefore no point in showing a diagram of one here.

The most noticeable difference is that their heater circuits must be decoupled, which would be unusual in a.m. circuits, and this applies whether the heaters of the receiver are in series for a.c./d.c. operation or in parallel. The kind of decoupling is shown in Fig. 70, because it is necessary whether the valve is a triode or a pentode. In Fig. 70 the heater is fed from a transformer secondary on a.c. mains, so one side of the heater goes directly to chassis. The other side is isolated from the other heaters by an r.f. choke L2, which may or may not have a ferrite core as indicated there. Either side of the choke is a capacitor C2, C3 of some 500–1,000 pF which ties the ends down to chassis potential.

A different method is shown in Fig. 71, which gives the circuit of the frequency changer stage. The two capacitors C12, C13 are there as before, but the place of the choke is taken by a ferrite bead FB1. This is a bead of ferrite material that is threaded on to the wire and makes it into an r.f. choke. The broken-line symbol looks something like the ferrite core of a coil, but it is distinguished by being a little thicker and having only two lines, whereas usually the coil core has three.

The local oscillator in Fig. 71 is a second triode V2, with an ordinary reaction coil L5 coupled back to the grid tuning coil L4 to produce oscillation. C11 simply blocks d.c. from L5, which would otherwise short-circuit the h.t. supply. L4 is tuned by several capacitors: C6 and C7 are connected in series across it, C9 is a fixed tuning capacitor, and C8 is a pre-set trimmer of very small value. C8 is not intended to do more than cover a limited trimming range, and C9 might have a negative temperature coefficient so that, as the set warmed up and the tuning tended to drift one way, the capacitance of C9 would drift in such a way as to compensate for the change, and keep the tuning constant.

The incoming signal is developed across the tuning circuit L3, C5 in V1 anode circuit and passed on to the grid circuit of V2, which operates as a self-oscillating mixer. Coupling to V2 is made at the junction of C6 and C7, which are usually of equal value (generally about 20–30 pF, but they may be smaller), and the signal and oscillator frequencies are mixed in the circuit associated with V2. A tuned-primary, tuned-secondary transformer T2 is tuned to the intermediate frequency, which is almost always 10·7 Mc/s, and it

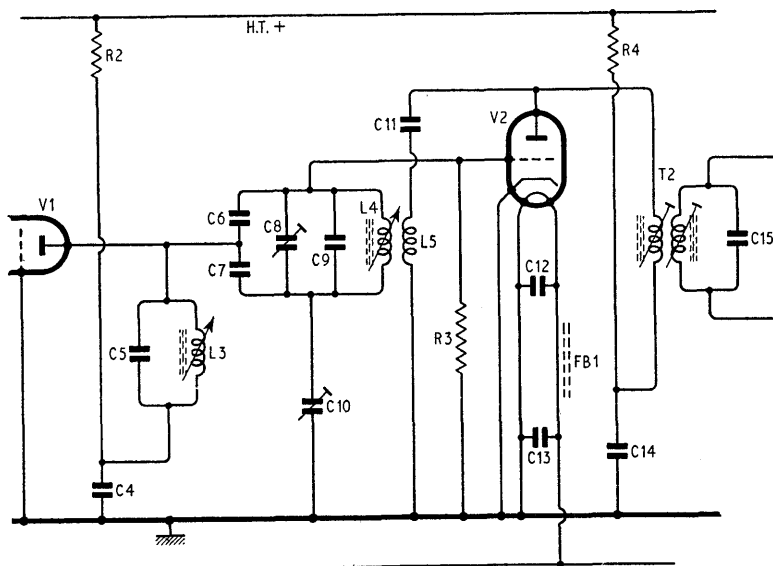

Fig. 71. The mixer stage of an f.m. receiver. L3 and C5 are those of Fig. 70, coupled to the centre of the oscillator circuit via C6, C7. V2 is a self-oscillating mixer, and T2 is the first i.f. transformer

selects that from the various frequencies present in V2 anode circuit.

As in the case of a.m. receivers, it is necessary to gang the tuning drive systems of V1 anode circuit and the oscillator circuit. In Fig. 71 the pointed arrowheads through the cores of L3 and L4 indicate that these are manually variable, as averse to the pre-set adjustments of the cores of T2, and actually they are the means of tuning the receivers. The two cores are usually coupled mechanically by cord, similar to a cord-driven cursor system, and they move together in and out of the formers on which the coils are wound as the tuning control is operated.

Ganged capacitors are often used for tuning, however, when they take the form of a miniature a.m. two-section tuning gang. C5 and C8 would then become variable, and that would, of course, be indicated in a diagram by a diagonal line through them with a pointed arrowhead. The line with a bar across its top, shown in Fig. 71 through C8, would be transferred to the core of L4, and another line would be added similarly to L3, to indicate that these cores had pre-set adjustments. The circuit of Fig. 71 would need to be modified slightly if ganged capacitors were used for tuning, because one side of C5 would then go to chassis and it would not be advisable to connect the other side to h.t. positive.

Because the high frequencies present in these circuits are difficult to screen and are likely to radiate from the receiving aerial and interfere with reception by other receivers, a neutralizing circuit is introduced in this stage to prevent the local oscillations of V2 from reaching the cathode of V1. This is in addition to connecting V1 grid to chassis and using it as a screen.

Neutralization is the explanation of the presence of C10. With three other capacitances in the oscillator circuit it forms what is called a "bridge" circuit, across which the full oscillator voltage appears in one direction, but no oscillator voltage in the other. This can be explained only by redrawing the oscillator circuit in a different form from that in Fig. 71, and then discussing the theory, but the digression is worth-while.

The bridge circuit is shown in Fig. 72. Here the essential components concerned are connected exactly as they are in Fig. 71, but the significant capacitances C6, C7, C10 and the input capacitance of V2 are arranged so that they form the sides of a square, while the oscillator tuning coil L4 "bridges" two of the corners. Now the full oscillator voltage appears across L4, and it is therefore present between corners *a* and *b* of the square. C6 and C7 form a capacitive potential divider across L4, and so do the input capacitance of V2 and the neutralizing trimmer C10.

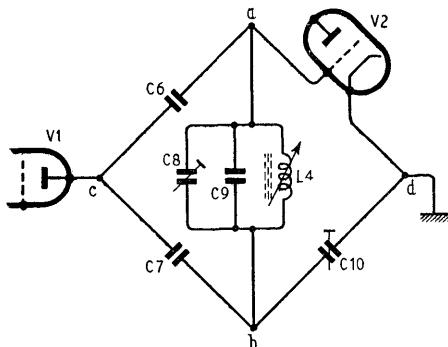

Fig. 72. The oscillator circuit of Fig. 71 redrawn to show the dispositions of the significant capacitances in the bridge neutralizing circuit

If the capacitances of C6 and C7 are equal, the oscillator voltage at their junction *c* will be exactly half the full voltage; and if the capacitance of C10 is adjusted until it is equal to the input capacitance of V2, the oscillator voltage at their junction *a* will be exactly half the full voltage. It follows therefore that *c* and *d* will both be at exactly the same oscillator potential and, so far as the oscillator goes, they could be joined together (with a d.c. isolating capacitor) without affecting it, because there is no (oscillator) voltage difference between them.

Now corners *c* and *d* are the anode of V1 and chassis respectively of Fig. 71, and if there is no oscillator voltage across the "bridge" *c,d*, then there is no oscillator voltage between V1 anode and chassis, and no oscillator voltage will be passed from the anode of V1 to its cathode.

In the hypothetical case above, we have assumed that C6 and C7 are of equal value, and that V1 capacitance and C10 are equal, but this is not necessary for the proper working of the neutralizing bridge. C6 and C7 could be unequal, but the bridge would still work provided that the proportions of C6 and C7 were equal to those of V1 input and C10, because *c* and *d* would then again be at the same oscillator potential, and there would therefore be no oscillator voltage difference between them.

Even though C6 and C7 are usually equal, it does not follow that the voltage at *c* will be exactly half of the total oscillator voltage, because stray capacitances may upset the balance between them, as may also happen on the opposite side of the bridge. In practice, however, C10 is adjusted not by measuring its capacitance and matching it to that of V2 but by measuring the oscillator voltage at V1 anode, or at its cathode. C10 is then adjusted for minimum oscillator voltage reading. This is usually done at the frequency

of the Third Programme, because that is the centre frequency of the three f.m. transmitters in a given area. The best neutralizing setting frequency at one frequency does not necessarily hold at others, but the centre frequency provides the best mean setting.

There are many small ways in which the diagrams of Figs. 69, 70 and 71 might be modified, apart from the major difference of using pentodes for V1 and V2, but in general the circuit of a commercially made domestic f.m. receiver is sufficiently like that shown in this chapter to be recognized quite easily. One feature that will be found nine times out of ten that has not been mentioned yet is that V1 and V2 are the two sections of a double triode valve, such as an ECC85 or a UCC85.

The aerial transformer T1 secondary is usually tuned by a pre-set ferrite core, and may actually be shunted by a fixed tuning capacitor while L3 in V1 anode circuit may not. Where tuned circuits are found apparently without tuning capacitors, the required capacitance is already present in the form of stray capacitance. C10 is sometimes a fixed capacitor. The primary of the i.f. transformer T2 may be connected in series with the reaction coil L5. As in a.m. oscillator circuits, the anode circuit may be tuned instead of the grid circuit, but this is unusual.

CHAPTER 33

F.M. I.F. STAGES

Although detail variations will be found in the circuit of one receiver as compared with another, the general pattern of intermediate frequency amplifiers in frequency modulated receivers is fairly consistent; furthermore, in a diagram little difference is perceptible between an f.m. i.f. amplifying stage and an a.m. amplifying stage.

In a complete i.f. amplifier there is the common difference that more stages are to be found in the amplifier, two i.f. amplifying valves being quite common, and three not exceptional. Beyond this, resistors are often shunted across the i.f. transformer windings to broaden their band-width, and tuning capacitors may be omitted, while some form of neutralizing is frequently used. A.G.C. is less common than in a.m. receivers, but sometimes a grid circuit limiter is used in the last i.f. stage to limit the input voltage to a predetermined level, so that a uniform carrier voltage is presented to the detector circuit irrespective of signal strength at the aerial. Limiting (of carrier voltage) is an important feature of f.m. receivers that is absent altogether from a.m. receivers.

The first i.f. transformer was shown as T2 in Fig. 71, and it is shown again in the first stage of an i.f. amplifier in Fig. 73, where V3 is the first i.f. amplifying valve. Two differences from a.m. circuits will immediately be apparent; firstly, that a resistor R8 shunts the primary of the second i.f. transformer T3, as mentioned earlier; and, secondly, that the decoupling circuits of V3 screen grid and its anode are coupled together by C18.

This latter arrangement is very common. Normally in an a.m. receiver C18 would go straight down to chassis, as shown in broken line, and sometimes it does this in an f.m. circuit, but if it is connected as shown in Fig. 73, C18 and C17 form a potential divider across which a small fraction of the anode signal voltage is developed. Provided that the values are suitably chosen, the signal voltage at this junction provides a neutralizing voltage at the screen grid which helps to maintain stability at these high frequencies.

Although this diagram looks so much like that of an a.m. receiver i.f. stage, it must be borne in mind that the components, which look alike in a diagram, have very different values. A.G.C. line decoupling capacitors are probably $0.001 \mu\text{F}$ instead of, perhaps, $0.01 \mu\text{F}$; C15 and C19 might be 10 or 20 pF, as against 100 pF; C18 and C17 might be $0.001 \mu\text{F}$ or $0.005 \mu\text{F}$ or thereabouts, instead of, say, $0.1 \mu\text{F}$.

Pre-set cores are usually employed in the i.f. transformer windings to provide a means of adjustment during alignment, and these are shown in Figs. 73 and 74. There they are indicated by the three broken lines to be of ferrite material, but often they are made of aluminium or brass, which has the opposite effect when adjusted. Whereas screwing a ferrite core into a coil *increases* the inductance, screwing in a non-ferrous metal core of, say, brass or aluminium *reduces* the inductance by causing increased eddy current loss. Metal cores are indicated in a diagram by the inclusion of the pre-set arrow without the three broken lines.

There might be two stages of i.f. amplification like that of Fig. 73 or only one, but there will then be another (making a total of two or three i.f. stages) which is in several ways different from the other(s). This is the final i.f. stage, of which a representative circuit is shown in Fig. 74. This diagram contains a number of special features, all different from those in an i.f. stage of an a.m.

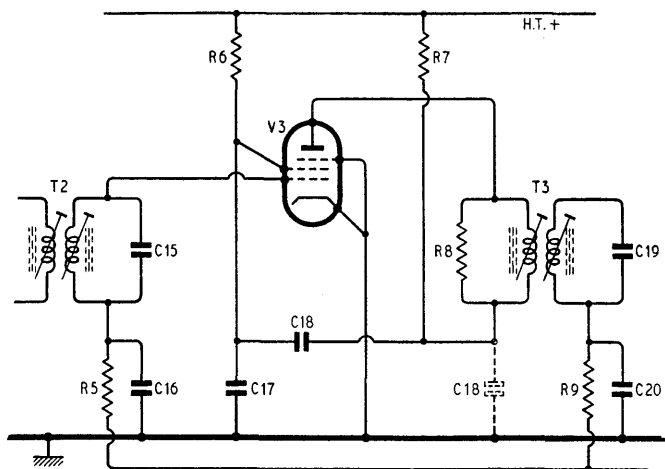

Fig. 73. Typical i.f. amplifying stage, of which there might be two in an f.m. receiver, in addition to the final i.f. stage of Fig. 74. The pre-set cores in the coils are shown as ferrite, but they may be made of aluminium or brass

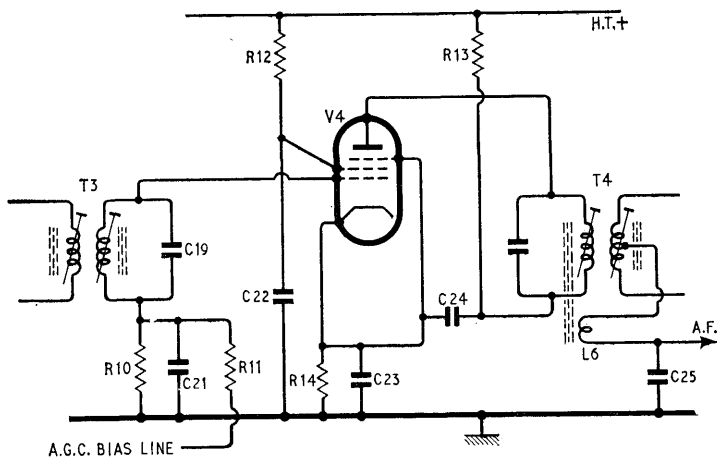

Fig. 74. The final stage of the i.f. amplifier, which feeds the f.m. discriminator, or detector. R10, C21 form a limiter which biases the valve and prevents the signal voltage from exceeding a predetermined value

receiver. Some of these will be found in most f.m. receivers, although they are not likely all to be present in any one receiver.

V4 in Fig. 74 is the final i.f. amplifier but, as we have just seen, there may be a third stage between V3 and V4. One of the essential features of this last stage is that it feeds the detector, or discriminator, stage but we have not yet come to that. A feature of Fig. 74 is that V4 has a limiting device in its grid circuit, which may or may not be present in a given receiver. If it is present, it will be in this stage, and it can be recognized by the insertion of the resistor R10 between T3 secondary and chassis, shunted by a capacitor. It is more likely to be present in a three-stage amplifier than in a two-stage amplifier.

The intention is that the signal applied to V4 control grid should always be large enough to overload the grid circuit and cause grid current to flow through R10, charging up C21 to a degree that depends upon the signal strength.

The voltages on V4 screen and anode are such that the valve "limits" very early and does not amplify the signal beyond a certain specified limit, so that it always passes on to the detector a signal of uniform voltage, provided that the signal is not too weak to be usable in the first place.

It was observed earlier that a.g.c. was not so common in f.m. receivers as in a.m. but, of course, the limiter constitutes a very

effective a.g.c. device by cutting down, or limiting, all signals to a predetermined value, irrespective of their original magnitude. The larger the signal, however, the larger the grid current flowing and therefore the higher the potential drop along R10. As shown in Fig. 74, this potential is sometimes tapped off and fed back to an earlier valve (or valves) as a.g.c. bias.

CHAPTER 34

F.M. DETECTOR STAGE

The most noticeable difference between the normal a.m. final i.f. amplifying stage and the f.m. one in Fig. 74 is the tapped secondary winding of the transformer T4 and the small coil L6 below it coupled back to the primary winding. This is a special feature of the f.m. detector circuit, or discriminator as it is often called, and this particular form of discriminator is known as a ratio detector.

A complete representative ratio detector circuit is shown in Fig. 75, and in general this is the most common type of circuit used in domestic receivers, although there are several other types that might be used. The one illustrated is called an unbalanced ratio detector, because one side of it is connected to chassis, at the cathode of the diode D2.

This detector has two load circuits, one for the signal voltage (a.c.) and the other a d.c. load circuit. The d.c. voltage is developed across R17, which is in series with the two diodes. This d.c. load is shunted by an electrolytic capacitor C28 of between $4\ \mu\text{F}$ and $10\ \mu\text{F}$ which prevents the d.c. voltage from changing rapidly. C27 which is connected directly across C28 is a small capacitor of, say, $100\ \text{pF}$ as an i.f. by-pass across the d.c. circuit.

The a.c. load impedance is provided by C25, across which the a.f. output from the detector appears. At the transmitter the high frequencies are amplified more than the low frequencies, and this is described as giving "pre-emphasis" to the higher frequencies in order to combat noise. In the receiver the signal has to be "de-emphasized" after detection to compensate for the pre-emphasis, and this function is performed by R16 and C26. As the a.f. signal in C25 is passed through R16, C26, the higher notes are attenuated relative to the lower notes, restoring an overall level response in the signal as it appears at the volume control R18.

From the volume control onwards there is no fundamental difference between an a.m. receiver and an f.m. receiver, the rest comprising an a.f. amplifier and output stage, but in some receivers

Fig. 75. A typical ratio detector circuit. T4 and L6 are parts of the same discriminator transformer as that in Fig. 74. The ratio detector is distinguished from other discriminators by the two diodes (which may be crystals) connected in series

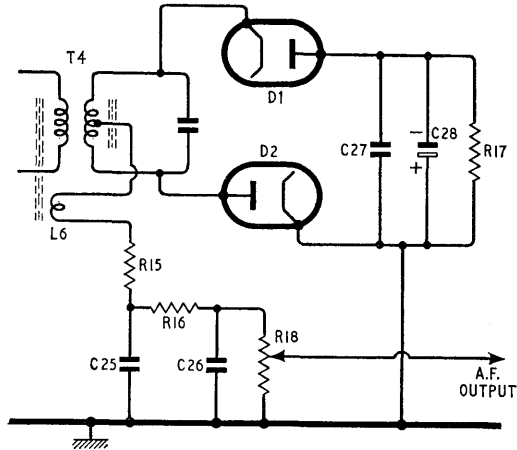

a wider frequency response is provided in the a.f. circuits to take advantage of the better quality that is obtainable with f.m. reception.

Of other forms of discriminator, or f.m. detector, there are only two worthy of note that are very different from the more common type shown in Fig. 75. One of these is also a ratio detector, but it is balanced, so that neither side of C27 goes to chassis. The other type of discriminator is usually referred to as the Foster-Seeley phase discriminator. It is second in popularity to the ratio detector and is the one usually employed in receivers designed specially to operate with high quality amplifiers.

A diagram of a representative Foster-Seeley discriminator is shown in Fig. 76. The principal differences between this and the ratio detector are that the phase-injection coupling capacitor C29 replaces L6, the two diodes D1, D2 are connected in opposition instead of in series, the r.f. by-pass capacitor C27 is divided into two separate capacitors, C27a and C27b, and that the a.f. output appears across the d.c. load resistances R17a and R17b.

Because the a.f. output is there, obviously the electrolytic capacitor C28 cannot be, and because the diodes are connected in opposition, so are the d.c. potentials developed across the load resistances. The centre-tap of T4 secondary is connected to the centre of the d.c. and a.f. load circuit, and the whole circuit is symmetrical. In some cases the centre-line of the circuit is actually earthed, but usually one end of the circuit is earthed as shown in Fig. 76. When the centre-line is earthed, the whole is described as a balanced discriminator circuit and in that condition it is very convenient for feeding a push-pull audio circuit.

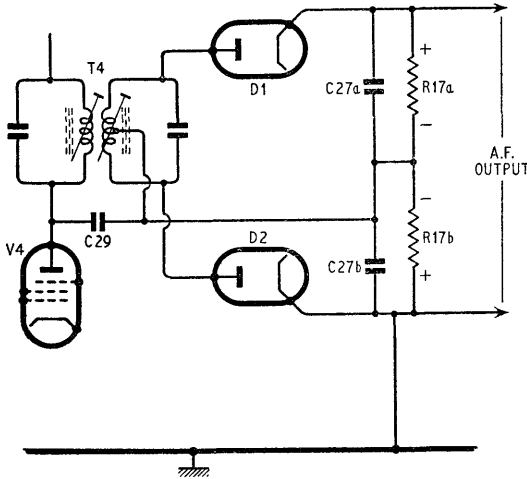

Fig. 76. Basic circuit of the Foster-Seeley discriminator. Note that the two diodes are connected the same way round and that their d.c. outputs across R17a and R17b are in opposition. The junction between these two resistors, instead of one end, may be earthed, especially when a push-pull stage follows

The balanced ratio detector is in the main like the unbalanced one of Fig. 75, but it maintains the centre-line, as shown in Fig. 76. It has C27a and C27b, and the bottom end of L6 is connected to their junction. The centre-tap of R17, which now comprises R17a and R17b, is connected to earth, and the a.f. output is taken as before from the bottom of L6 (probably via R15) and is thus at chassis potential to i.f. Therefore the i.f. and d.c. part of the circuit are earthy, in that the whole circuit is symmetrically disposed either side of chassis and is thus balanced.

Automatic gain control of the type used on a.m. receivers is not always applied to f.m. circuits, although it is used occasionally. Something similar is necessary, of course, if the f.m. receiver is equipped with a tuning indicator, and one is usually fitted to the better models. The bias potential for the a.g.c. line is readily available in the ratio detector circuit because quite a useful voltage is developed across the d.c. load circuit. In Fig. 75 it is stored in C28 which, as can be seen from the polarity signs, is positive on the chassis side and negative on the upper side.

Therefore a lead taken from the upper end of R17 would be at a negative potential with respect to chassis, and although the instantaneous volume of sound in f.m. reception is proportional to the extent, or amplitude, of the change of the carrier frequency, the long-term or overall signal strength is proportional to the amplitude of carrier, which itself in a given transmission, should not vary in magnitude unless fading occurs. A weak signal can remain constant at a low level, however, and a constant low d.c. voltage would then be

developed across C28. Alternatively a strong signal can similarly produce a constant but larger d.c. voltage across C28. This assumes, of course, that no limiter is used. A limiter would restrict the signal passed on to the discriminator to a predetermined level.

If a limiter is used, provided that the signal being received is not too weak, the signal voltage handed on by the last i.f. amplifier V4 to the detector is always the same, irrespective of signal strength, and in such cases a.g.c. could not be taken satisfactorily from the detector circuit. The limiter in V4 control grid circuit itself, however, still provides a source of a.g.c. potential if it is required.

If the signal voltage reaching the detector is allowed to vary with signal strength, then the a.f. output and the d.c. load circuit voltage will both be larger for a higher signal strength. While this useful condition is not frequently used as an a.g.c. source to vary the control grid bias to the i.f. valves, it is quite a common practice to take a lead from the top of R17 (in Fig. 75) directly to the suppressor grid of V4, which in Fig. 74 is shown connected to V4 cathode. This device aids V4 in maintaining a uniform signal voltage for the detector, because a.g.c. applied to the suppressor grid can control the gain of the valve. When the top of R17 is connected to the suppressor grid, of course, the connection between the suppressor grid and cathode is removed.

Although occasional references are made from time to time in this book to theoretical features of circuit design, in general it is concerned only with the kinds of circuits that are used and not with the theory behind them. Most readers will have sufficient knowledge of theory to understand how the majority of circuits work, but fewer may understand how the discriminator in an f.m. receiver works. For their benefit a simple explanation is given in the Appendix, where it need not be read by those who already understand the principles on which it operates.

CHAPTER 35

COMBINED A.M./F.M. RECEIVERS

Since the audio frequency circuits can be the same for a.m. and f.m. receivers, and many listeners would like to be able to receive programmes from both kinds of transmission, it is logical to try to marry the two systems together and include the two systems in one receiver. This is commonly done, and in the days of valve receivers most of the ordinary domestic radio receivers and radiograms were described as a.m./f.m. models. Many of them still are today.

It is surprising how simple some of the circuits are, bearing in mind that they are very different in all the stages right up to the detector and that only the audio circuits are common. It will be realized that the h.t. and heater supplies can also be common, but it is also found in practice that most of the valves can be used for both systems of reception as well.

The simplest way of showing how the two systems are combined in an a.m./f.m. receiver is to use a block diagram, and a representative one is shown in Fig. 77. Here, for a.m., the normal type of a.m. circuit is employed, using a frequency changer (V3), an i.f. amplifier (V4), a diode a.m. detector, followed by a triode a.f. amplifier and a pentode output valve. The last two are not shown, but they follow the volume control, of course. The r.f., i.f., and detector circuits could be any of those described in Chapters 1-17.

The f.m. circuit is also of the normal type as depicted in our diagrams in Figs. 69-75. The aerial and r.f. amplifier in V1 stage are those of Figs. 69 and 70, and V2 stage is that of Fig. 71, while the f.m./i.f. transformer T2 in Fig. 71 is shown as a separate block. V3a in Fig. 77 is the mixer section of the a.m. frequency changer, whose triode oscillator section V3b is put out of action for f.m. operation. On f.m., V3a acts as an i.f. amplifier, as though it were an ordinary pentode valve.

The i.f. transformers I.F.T. comprise ordinary separate a.m. and f.m. transformers, connected in series in each stage, with V4

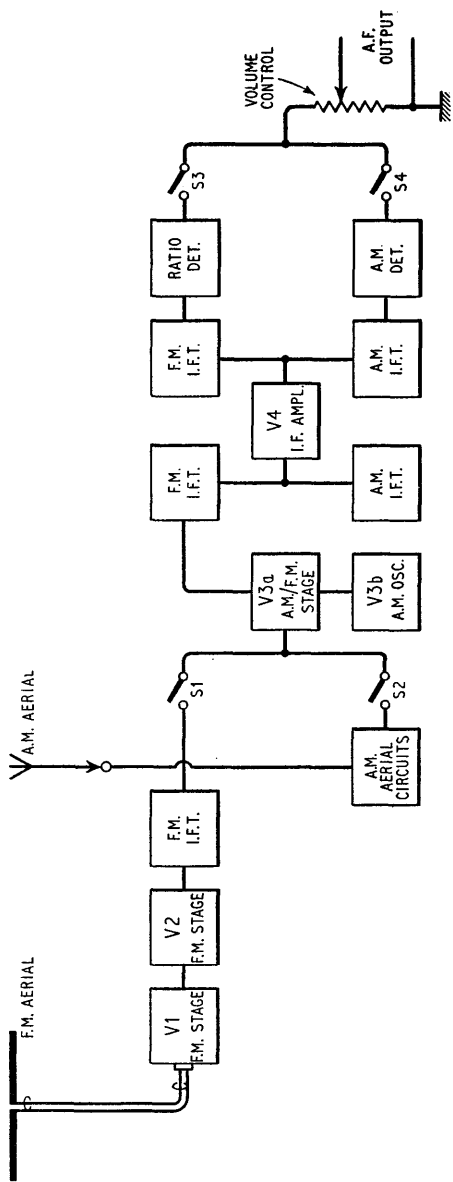

Fig. 77. Block schematic diagram of an a.m./f.m. receiver, from the two separate aeri- als to the volume control, whereafter the circuit is common to both systems. V3 acts as a fre- quency changer on a.m., and its pentode (or heptode) section acts as an i.f. amplifier on f.m.

connected between the two pairs and amplifying on the appropriate system according to the frequency of the signal that is coming in. If the system is a.m., the frequency will usually be 470 kc/s, and if it is f.m., it will usually be 10.7 Mc/s. Only the appropriate transformers will respond to these frequencies.

Thus the appropriate transformer in the anode circuit of V4 will develop a signal in its windings, and its secondary circuit is permanently connected to a suitable detector circuit. Therefore, on f.m., a signal will appear at the ratio detector for rectification, and, on a.m., a signal will appear at the a.m. detector. In either case the selector control on the receiver will be switched to an a.m. waveband or to f.m., and the switches S1 and S3 will close for f.m., or S2 and S4 for a.m., so that only the correct type of signal will reach V3, and only the appropriate detector output will be taken to the volume control.

Details of the circuitry associated with the final i.f. amplifier V4 and the two detector stages of an a.m./f.m. receiver are shown in Fig. 78, where new features of the a.g.c. circuit as it is in some receivers are included. Most of the f.m. circuits are redrawn from Figs. 74 and 75, and their component numbers are the same so that they can easily be identified. The a.m. and f.m. transformers are indicated.

The manner in which the a.m. and f.m. i.f. transformers are connected in series can now be seen, although of course the arrangement shown is only one of many variations. It does, however, demonstrate the general pattern. Infrequently a switch is used to short-circuit one of the transformer coils while it is out of use, and this would be connected across one of the windings of T3 or the a.m. transformer below it.

Usually the two detector circuits remain in circuit permanently, but the switches S3 and S4 are always used, and there might also be a third one for the connection of a gramophone pick-up across the volume control R18.

In Fig. 78 is shown the connection of V4 suppressor grid to the ratio detector d.c. load circuit. This was referred to earlier in this book as giving a measure of a.g.c. and assisting the limiting function of V4.

There are many varieties of a.g.c. circuits in a.m./f.m. receivers, but in most cases their purpose can be deduced from a study of the circuit diagram. One method of obtaining a.g.c. for f.m. only was shown in Fig. 74, where a limiter was used, and this might be employed in an a.m./f.m. receiver. In such a case switching might be used to connect the bottom of R10 to the a.m. a.g.c. line when the

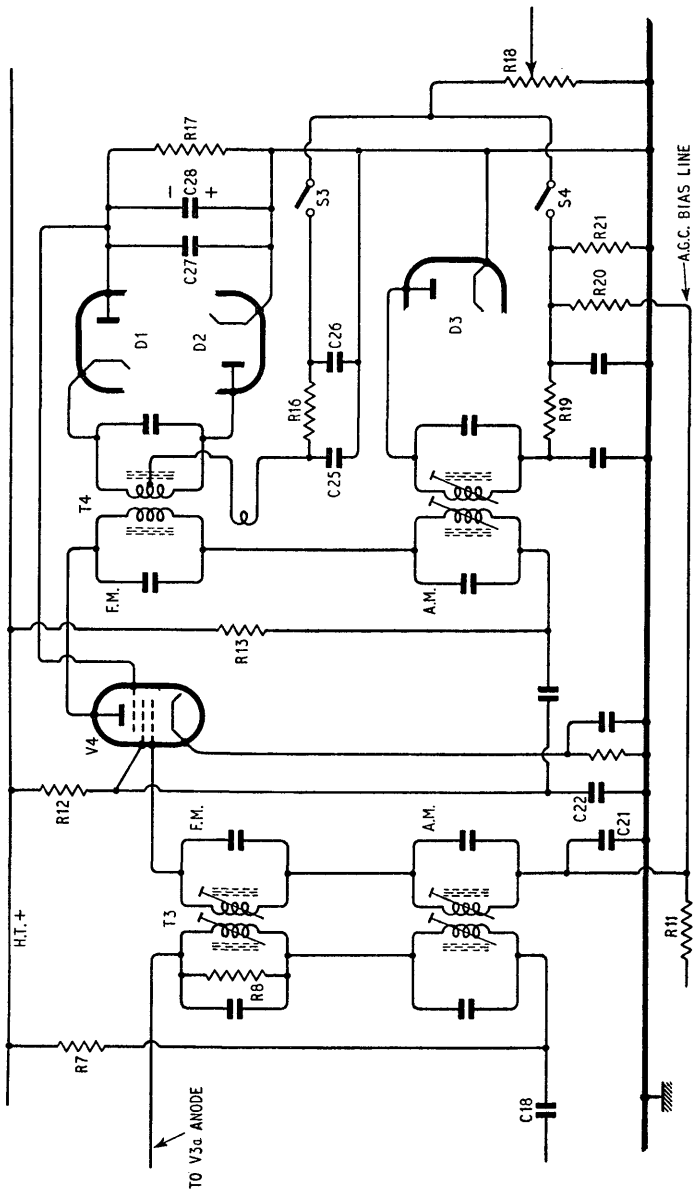

Fig. 78. Complete circuit of the final i.f. and detector stages of a typical a.m./f.m. receiver of the kind sold commercially for domestic use. The component reference numbers of the purely f.m. parts of the circuit are the same as those in Figs. 74 and 75, but the function of R10 in Fig. 74 is performed here by R20 and R21

set was switched over to a.m., so as to *apply* a.g.c. to V4 instead of deriving a.g.c. from it, but in Fig. 78 a more subtle and economical method achieves the same result.

It will be seen in Fig. 78 that V4 control grid circuit is returned from the bottom of the a.m. transformer secondary directly to what looks like the ordinary a.m. a.g.c. line. And on a.m. that is what it is, but on f.m. the circuit becomes a modified version of the limiter shown in Fig. 74. R11 in Fig. 78 is the same R11 as the one in Fig. 74, and C21 is identical as well, but the function of R10 is performed by the a.m. detector load resistance R21 and the decoupling resistance R20. Like R10, they are connected directly between the bottom of the transformer and chassis. On a.m. they operate the same way as they do in a normal a.m. receiver, and a.g.c. bias appears on the a.g.c. line and R20 acts as a decoupling resistance. On f.m. they perform a similar function as a result of grid current from V4, but R20 then forms part of the load resistance in the grid circuit of V4.

Another variety of a.g.c. circuit that has been used several times employs switching to connect the a.g.c. line to the a.m. detector circuit during a.m. working, and to the d.c. load circuit of the ratio detector (the negative side of C28) during f.m. working.

A special type of valve has been designed for use in a.m./f.m. receivers. It is a very high impedance triode with three diodes, so it is a triple-diode-triode. Its Continental number is EABC80 (or UABC80 in a.c./d.c. circuits) and it is shown in diagrammatic form in Fig. 79. The triode section forms the a.f. amplifier that follows the volume control R18 in Fig. 78, and the three diodes are D1, D2 and D3 in the same diagram. It will be observed that a single cathode serves three sections of the valve (D2, D3 and the triode) and this cathode is almost invariably connected to chassis. Only the D1 section is provided with a separate cathode and, as can be seen from Fig. 78, this is necessary because that cathode has the f.m. signal applied to it.

The triode circuit is unusual in that it does not use cathode bias owing to the earthing of its cathode. Instead its grid resistor has a very high value, usually 10 megohms, and as a result a minute grid current flows all the time the cathode is heated. One microampere flowing through it, of course, would produce a drop of 10V, and this facility is used to obtain grid bias for the valve, although the grid current is probably lower even than 1 microampere. The whole effect is that described earlier as "contact potential".

As we have already seen, a double-triode valve is usually employed for the r.f. amplifier and self-oscillating mixer identified as V1 and

Fig. 79. Diagram of the special triple-diode-triode valve for the detector and a.f. amplifier stages of a mains-operated a.m./f.m. receiver. It is usually broken up in a diagram into its four parts, which are then labelled a, b, c and d

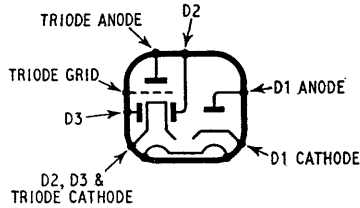

V2 in Figs. 70 and 71, where they are shown as complete and independent triodes. They are, however, almost invariably a special double-triode valve of the ECC85 type, to give it its Continental nomenclature (or UCC85 in a.c./d.c. circuits). This valve is special in the sense that it is designed to operate at v.h.f., particularly in the "front end" circuits of an f.m. receiver, with a v.h.f. signal applied to one of the cathodes, while the two triode sections are isolated from each other by internal screening. There are often other multiple valves also, such as the triode-pentode frequency changer V3 in Fig. 77.

When drawing valves of the multiple type in a diagram, it is usual to put the respective sections in their proper places in the diagram, and to draw only half of the envelope circle round them, to indicate that they are parts of a multiple valve. Thus the several sections of a valve might well be separated and shown as half-valves, as are the three diodes in Fig. 78. As a rule, however, they would not be given different numbers, but would all be numbered as parts of one valve, in this case usually V5. D1 would then become V5a, D2 V5b, D3 V5c, and the triode section V5d. In the same way, V1 and V2 are usually numbered V1a and V1b, as is done with V3a and V3b in the block diagram of Fig. 77.

The other valves in the common type of a.m./f.m. receiver are also of special design, although they have no special characteristics that can be seen in a diagram, as can those of V1 and the triple-diode-triode valve. The a.m. frequency changer-cum-f.m. i.f. amplifier (V3 in the block diagram of Fig. 77) is usually an ECH81 (or UCH81) type, and the pentode i.f. amplifier is an EF89 (or UF89). The a.f. output valve is often an EL84 (or UL84) type, but that is only because it is one of the same series of valves that was in general use in the period of which we are reading. The kind of output valve is not specially chosen because the receiver is of the a.m./f.m. type, and any kind of conventional a.f. output circuit can be used, provided, of course, that it can work from the signal handed on to it from the triode section of the special triple-diode-

triode valve. The complete circuit diagram of a representative a.m./f.m. receiver (opposite page 166) shows the kind of a.f. circuit that is employed in such models. In common with normal circuit diagram practice the first two valves, which share a common envelope, are designated *V1a* and *V1b*, so that the last i.f. amplifier becomes *V3*, instead of *V4* as it is in the bulk of the preceding text, and *V4* is the triple-diode-triode valve. Also, the ratio detector is drawn below the a.m. detector, whereas in Fig. 78 it is drawn above it. This makes no difference to the circuit, and it can be drawn either way round.

CHAPTER 36

TRANSISTOR CIRCUITS

Transistors are devices which can be used instead of valves to amplify electrical signals. They are made in a wide variety of kinds and, although they perform similar functions, they operate differently from valves because in some technical features their behaviour is opposite to that of a valve; but a signal applied to the input of a transistor stage can be taken off in amplified form from its output in the same way as it can with a valve. The theory of transistor operation is extremely complex, and therefore it cannot be explained in the simple physical terms that can be used to explain valve theory.

“Solid state” and “semiconductors” are terms that are often used in relation to transistors. The term “solid state” derives directly from the comparison of the transistor with the valve. The valve is characterized by its construction of electronic elements within an evacuated glass envelope, and it is anything but solid. In comparison the transistor is constructed, by chemical processes, of entirely solid germanium or silicon. The term “semiconductor” derives from the electrical characteristic of the material from which transistors are made and the manner in which it is treated, because it is neither an insulator nor a normal conductor. These terms are also applied to devices other than transistors, such as crystal diodes, rectifiers, photo diodes and other solid devices that perform similar functions to those that have in the past been performed by valves. Therefore a “solid state” amplifier or other equipment is merely one that uses transistors and possibly other semiconductors instead of valves.

There are many applications in electronics in which the transistor has almost completely replaced the valve, and that applies particularly to domestic radio receivers. Most of these are now portables, even to the extent that the transistored portable has replaced the table receivers for use in the home, but conventional valve circuits are still used in some radiograms. Readers who would like to

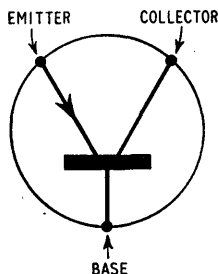

Fig. 80. The most widely accepted symbol for a transistor. The names of the three "electrodes" are indicated

know more about transistors and the theory of their operation are referred to books that deal specifically with this subject.*

The most widely accepted symbol for a transistor is indicated in Fig. 80, but although it is shown there with its base "electrode" (a transistor does not have electrodes in quite the same sense that a valve does) horizontal, it may be drawn in other positions. A valve symbol might be drawn in different positions, of course, and for the same reasons as is the transistor, and the number of varieties of connections and arrangements of the transistor is very much the same as those of the valve.

The material of which transistors are made is usually germanium or silicon, and either of them can be treated to give it a positive or negative character, although this does not infer that they have those relative polarities applied to them from the power supply. The character of the material is indicated in a general classification by the letters "p" and "n", the "p" indicating positive and the "n" negative.

The three basic modes in which transistors may be operated are shown in Fig. 81, where the polarity of d.c. potentials applied to them for such purposes as the equivalent of h.t. supply with valves is indicated. The emitter can be recognized by the arrowhead, and it will be remembered easily that the arrow points in the direction of "conventional" current flow, from positive to negative.

Readers who are meeting transistors for the first time will have to accustom themselves to accept as a fact the very low voltages indicated in Fig. 81 as being the equivalent of the high tension circuit in valve receivers. It is difficult to believe, but quite large output powers can be delivered from transistors with battery voltages of between 6V and 24V, for instance, and a common range is 9V to 18V. Some portable receivers use only 3V or 4.5V.

The three modes of operation are termed "common base", as shown at (a) where the base is common to input and output

* See Bibliography at the end of this Chapter.

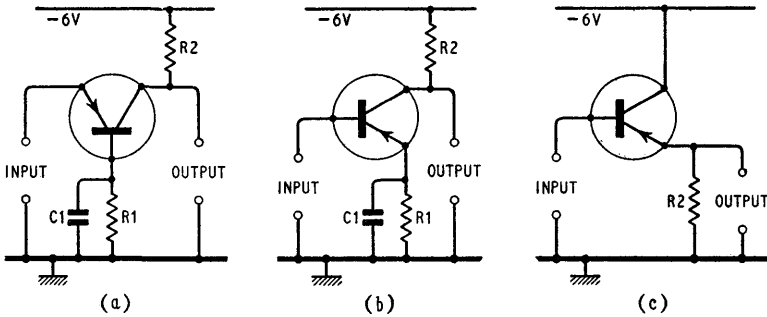

Fig. 81. Basic arrangements of the three modes in which a p-n-p transistor may be used. They are (a) common base; (b) common emitter; (c) common collector circuits; "common emitter", as at (b) where the emitter is common to both circuits; and "common collector", as at (c) where the collector is common to (or in the earthy end of) both input and output circuits. The collector is earthy in (c) because the battery circuit is at earth potential at both ends, as in all radio circuits. R1 is a bias resistance only, and it is by-passed by the capacitor C1. R2 is the output load resistance.

It should be observed that in each diagram the emitter is positive with respect to the base, as indicated by the arrow, and that the battery (or other power supply) line is marked 6V negative, or minus 6V. That is the way these transistors work: positive emitter, and negative collector, and a low voltage d.c. power supply. The "grid" bias potential derived from R1 is only a fraction of a volt. There is no filament or heater, and therefore no l.t. supply. Battery voltage varies between 3V and 24V, and this takes the place of the h.t. supply in a valve circuit.

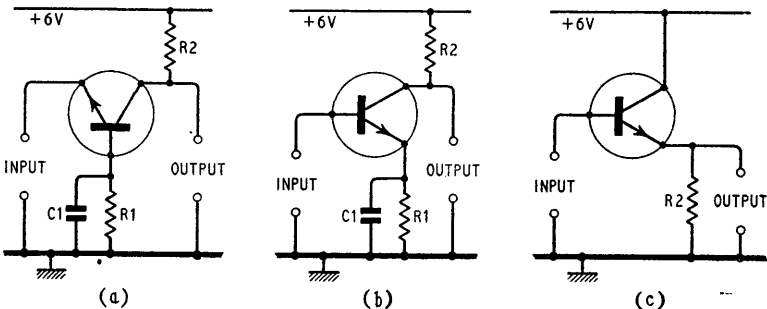

Fig. 82. The three basic modes in which an n-p-n transistor may be used are shown at (a), (b) and (c). It will be seen that apart from polarity they are the same as those in Fig. 81

The transistors in Fig. 81 are known as p-n-p transistors, because they consist (if they are junction transistors) of an area of "n" type germanium sandwiched between two areas or slices of "p" type. There is another type of transistor known as n-p-n type, however, for the now fairly obvious reason that it consists of an area of "p" type material between two areas of "n" type. Apart from this difference, the two types of transistor are alike, and they use exactly the same kinds of circuits, but because their "natural" polarities are reversed, all the d.c. operating potentials to them must be reversed. An n-p-n transistor is usually made of silicon.

The effect of this is shown in Fig. 82. This is redrawn from Fig. 81, and but for two small but significant details it is seen to be the same as Fig. 81. The first difference is that all the polarities are reversed, and the power supply line becomes positive. The second is that the arrowhead by which the emitter is distinguished is reversed, indicating that the emitter is *negative* with respect to the base.

It is necessary in an introduction to transistors even as superficial as this to explain these details because they will be encountered frequently in circuit diagrams. It is important to remember the difference between p-n-p and n-p-n transistors because, while the p-n-p type is used by most British domestic manufacturers, practically all American and Japanese receivers use the n-p-n transistor. The type in use can be recognized at once in a diagram by the direction of the arrowhead; and provided that n-p-n and p-n-p transistors of similar characteristics are used, a circuit employing either type can be converted to the other by replacing the transistors (or reversing the arrows in a diagram) and reversing the polarity of the d.c. supply. Thus a given circuit can be converted from one type to the other simply by reversing the arrowheads on the transistors and reversing the polarity of the battery.

BIBLIOGRAPHY

- AMOS, S. W., *Principles of Transistor Circuits*, 3rd edition, Iliffe (1965)
HIBBERD, R. G., *Transistor Pocket Book*, Newnes (1965)
RODHAM, T., *Transistor Inverters and Converters*, Iliffe (1963)
LANE, C. F., *Servicing Transistor Radios and Printed Circuits* (edited by E. A. W. Spreadbury), Iliffe (1962)
CATTERMOLE, K. W., *Transistor Circuits*, 2nd edition, Heywood (1962)
BETTRIDGE, B. R. A., *Transistors: Circuits and Servicing*, 2nd edition, Iliffe (1960)
The Mullard Reference Manual of Transistor Circuits, Mullard Limited (1960)
(Available from Mullard Ltd., or from radio dealers.)
AMOS, S. W., *Portable Transistor Receiver*, Iliffe (1958)

CHAPTER 37

TRANSISTORED RECEIVERS

It would be misleading to imply that transistored circuits are similar to valved circuits, but it is helpful to those who have familiarized themselves with valve circuits to say that the circuit principles on which they are based are the same with the exception that transistors are characterized by low impedances compared with a valve. As a result they operate with much lower voltages for somewhat similar currents, and actually they are more readily characterized by their currents than by their voltages, which is the opposite to valve operation. The amplitude of an input signal to the base of a transistor, for instance, is measured in milliamperes or microamperes, and not in voltages as is the signal input to the control grid of a valve.

This affects the circuits in several respects, particularly in the d.c. circuits of the power supplies to the transistors and in the impedances of couplings to and from tuned circuits. It also results in very different values for such components as resistors and capacitors, and again there is a complete absence of a heater or filament circuit. But otherwise than for these considerations the tuning circuits are fundamentally the same for valves or transistors, and the sequence of stages, from aerial to loudspeaker is the same except for an additional transistor stage here and there, as in the i.f. amplifier for instance. Special types of output stage circuits are often employed, but they, the tuning circuits, the battery feed circuits, decoupling circuits, feed-back systems, tone control and a.g.c. systems are all related to the techniques of which we have read in the earlier chapters of this book, and this chapter will explain them by reference to those chapters.

A representative diagram of the aerial, f.c., i.f. and detector circuits of a portable transistor receiver designed for a.m. only, not for f.m., is shown in Fig. 83, which is complete but simplified as far as possible. L2 and L3 are the m.w. and l.w. tuning coils, wound on a small ferrite aerial rod and tuned by a (physically) very small but otherwise conventional variable capacitor. Because the input

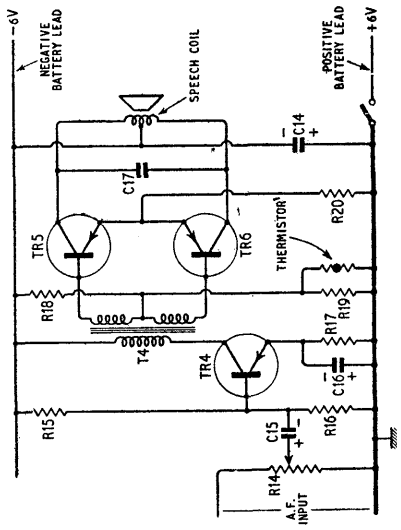
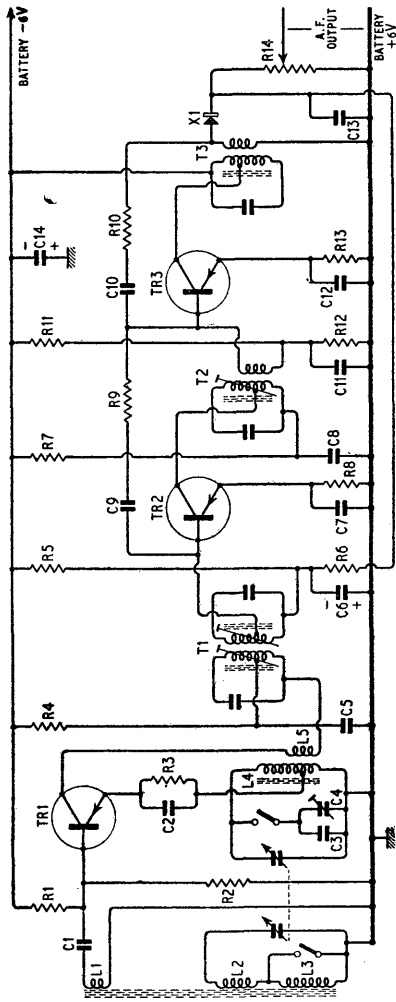
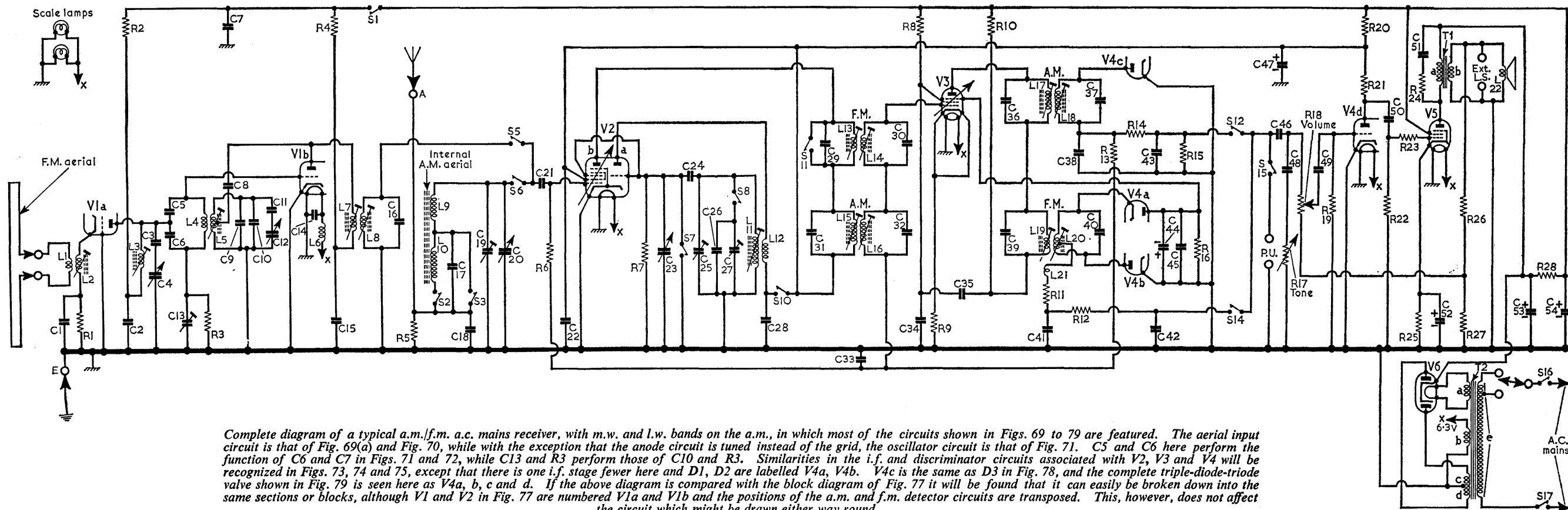
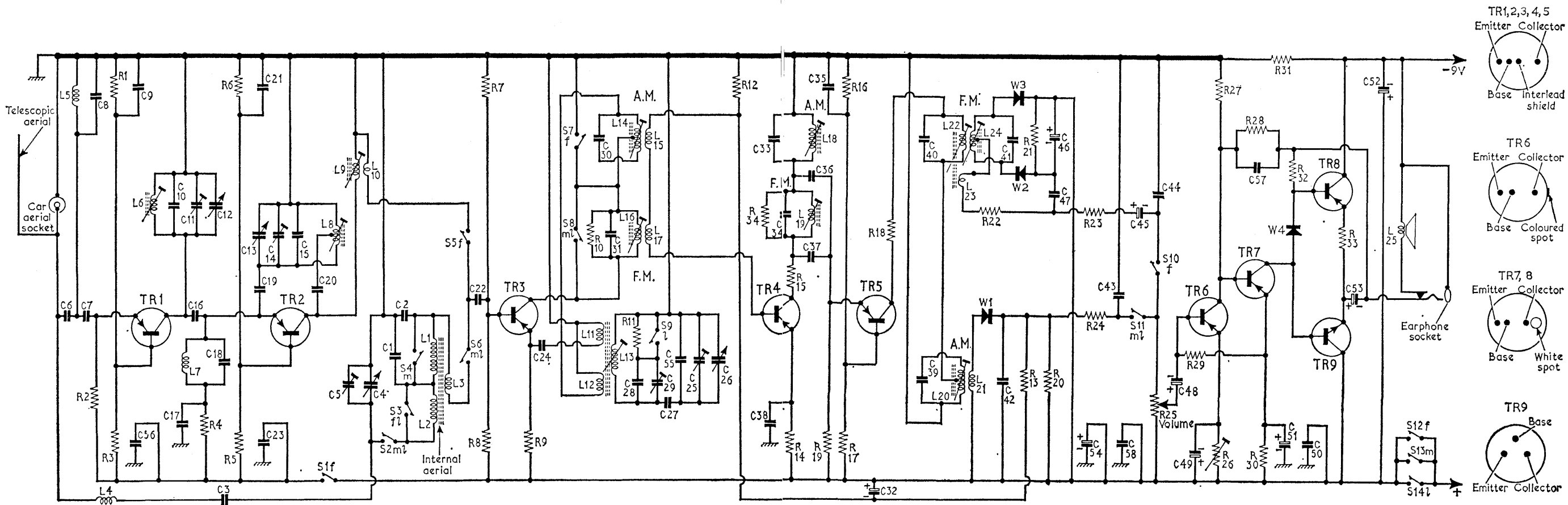

Fig. 83 (above). Representative diagram of a receiver using transistors instead of valves. It is assumed to be a portable, driven from a 6V battery, picking up its signal from the ferrite rod aerial on the left. The audio frequency signal appears across the volume control R14 on the right. The remainder of the circuit is shown in Fig. 84

Fig. 84 (right). The audio frequency stages of the receiver whose earlier stages are shown above, the volume control R14 being common to both diagrams. TR4 is the a.f. amplifier, driving the push-pull pair of output transistors TR5, TR6. If the latter operate in class B, TR4 becomes a driver stage. The push-pull output circuits vary considerably, but this one is typical



Complete diagram of a typical a.m./f.m. a.c. mains receiver, with m.w. and l.w. bands on the a.m., in which most of the circuits shown in Figs. 69 to 79 are featured. The aerial input circuit is that of Fig. 69(a) and Fig. 70, while with the exception that the anode circuit is tuned instead of the grid, the oscillator circuit is that of Fig. 71. C5 and C6 here perform the function of C6 and C7 in Figs. 71 and 72, while C13 and R3 perform those of C10 and R3. Similarities in the i.f. and discriminator circuits associated with V2, V3 and V4 will be recognized in Figs. 73, 74 and 75, except that there is one i.f. stage fewer here and D1, D2 are labelled V4a, V4b. V4c is the same as D3 in Fig. 78, and the complete triple-diode-triode valve shown in Fig. 79 is seen here as V4a, b, c and d. If the above diagram is compared with the block diagram of Fig. 77 it will be found that it can easily be broken down into the same sections or blocks, although V1 and V2 in Fig. 77 are numbered V1a and V1b and the positions of the a.m. and f.m. detector circuits are transposed. This, however, does not affect the circuit which might be drawn either way round



Typical of commercially marketed a.m./f.m. transistored receiver circuits, this one is actually that of a portable model. It provides an example of the earthed negative line, indicated by the thick line at the top. On f.m., the r.f. amplifier and self-oscillating mixer stages TR1 and TR2, which are connected in the common base mode, comprise the f.m. tuner unit. They are followed by three i.f. amplifier stages TR3, TR4 and TR5. On a.m. TR1 and TR2 are switched out by S1f, and the receiver then comprises TR3 operating as a self-oscillating a.m. mixer and two i.f. stages TR4, TR5. The audio stages, from the volume control R25 onwards, culminate in a complementary output pair TR8, TR9, and these stages are common to a.m. and f.m. reception.

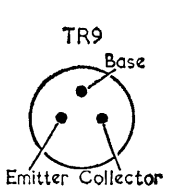
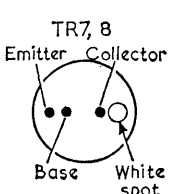
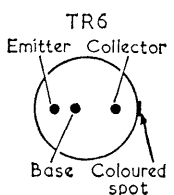
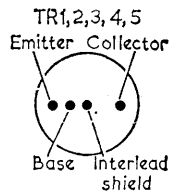

to the base of a transistor is of low impedance, coupling to the first transistor TR1 is made through the medium of the coupling coil L1. R1, R2 form a potential divider to bias the base, which performs the same function as the control grid in a valve, and C1 merely isolates L1 so that it shall not short-circuit R2. The value of R2 is usually about one-fourth or one-fifth of that of R1, and common values are 6.8 k Ω and 33 k Ω respectively. R3 is usually 1 k Ω .

TR1 operates as a self-oscillating triode "additive" frequency changer, oscillation being achieved by back-coupling the collector (which may be likened to the anode of a valve) to the emitter (which may be likened to the cathode) via L5 and L4. In the emitter circuit is connected the oscillator tuning circuit L4 and the second section of the tuning capacitor gang. The switch closes for l.w. operation, shunting C3 across the coil, while C4 is shunted across C3 to permit trimming to be carried out on l.w. It is unusual to use a separate l.w. coil and short-circuit it on m.w., as is done in the aerial circuit and in most valved receivers.

The emitter lead is tapped into L4 near the bottom of the coil, again because the emitter impedance is very low, because where we normally reckon to deal with voltages in valves, we deal with currents in transistors. R3 is simply a bias resistor, acting like the cathode resistor in a valve, and C2 by-passes it.

The intermediate frequency resulting from the combination of signal and oscillator frequencies is selected by tuning the i.f. transformer T1 to it. The primary winding of T1 is connected in series with the collector coil. The tapping again is to accommodate the low impedance of the collector circuit which, however, is much higher than that of the base or the emitter circuit. The tappings on the primary and secondary of T1 are shown equal in the diagram, but as the latter goes to the base of TR2 it would be a good deal lower down than the former. R5 and R6 form a potential divider, again for base bias to TR2, which is an i.f. amplifier. The lead going down and along to the volume control provides automatic gain control. The second i.f. transformer T2 follows conventional practice, R7, C8 decoupling the battery feed to the collector of TR2 as would similar components in the h.t. feed to a valve anode.

T2 has a low impedance coupling coil, like L1 in the aerial circuit, to couple the signal to the base of TR3, instead of a tapping well down the coil. This is an alternative arrangement to that of T1 and is shown here simply to give an example of each type, although usually both transformers in a given receiver would be alike. The principal difference between the two kinds is that in TR1 both

windings are tuned, making it more selective than TR2 which has only a single tuned winding.

The output from TR3 collector is coupled by T3 to a germanium crystal diode detector X1 with which volume control R14 operates as the load resistance. It should be observed that R6, in the base bias potential divider for TR2, is returned to the "top" of R14. The polarity of the rectified d.c. potential developed along R14 will be such that it is positive at the "top" of the resistance, so that the larger the rectified signal, the more positive will become the base potential of TR2 relative to that of its emitter, and this will reduce the gain of TR2. Otherwise this part of the circuit is similar to that of a receiver using valves, and the a.f. signal appears across R14.

The series C9, R9, C10, R10 between X1 and TR2 base is a neutralizing network that was used in early receivers, but it is seldom necessary with modern transistors. When it is used, the values are fairly critical, and usually they have to be checked if a transistor is replaced. If they are incorrect, instability or low gain will result.

Fig. 84 shows a representative circuit of the simplest kind of a.f. stages that might follow the receiver circuit of Fig. 83. Assuming that R14 is the same volume control as that in Fig. 83, the a.f. output from the crystal diode detector is passed via the volume control to the base of the a.f. transistor TR4. There again the pattern is repeated, a potential divider R15, R16 to provide a stable base bias and a resistance R17 to act as the emitter bias.

It is usual in audio frequency circuits to use electrolytic capacitors for coupling, as is shown for C15, and for decoupling, as C16, because the impedances in these circuits are very low, and the signal voltages are quite small as well. C15 would be something like $4\ \mu\text{F}$ to $8\ \mu\text{F}$, while C16 might be $50\ \mu\text{F}$ or $100\ \mu\text{F}$, although their working voltage of course is extremely low.

The output stage of a transistor receiver is subject to more variety of circuitry than is any other part of the receiver. It is common practice to employ an a.f. coupling transformer like T4 to couple to the collector of TR4 to the base electrode(s) of the output transistor(s), but while push-pull output is fairly common, because that is the best way to obtain a sufficient power output, single-output stages are occasionally used in very small receivers. Where push-pull is used it is almost invariably in the form of a Class B circuit on the principle described in Chapter 23.

Only the simplest type of push-pull output stage is shown in Fig. 84, but it is as representative as any. It will be observed that the output transformer is dispensed with in our drawing, a tapped

speech coil winding being directly connected to the collectors. This was at one time quite a common arrangement because it dispenses with the cost, weight, bulk and distortion that accompany the transformer, and as the load impedance is very much lower than would be required for valve circuits the speech coil is not difficult to wind, but it has been succeeded by a number of other methods that achieve the same objective. Nevertheless the same type of circuit is sometimes used with an output transformer, the transformer primary being connected where the speech coil is shown in Fig. 84.

There is a variety of this circuit in which the speech coil is not tapped but is connected between the junction of the two output transistors and a tapping half-way down the battery, so that if a 6V battery were used there would be 3V between it and chassis and 3V between it and the 6V negative battery line. A circuit employing this technique with a 9V battery line ($4.5V + 4.5V$) is shown later in Fig. 90 in Chapter 39. When an output transformer is used it is connected conventionally, and the secondary might be shunted with a potential divider from which a negative feed-back voltage is tapped off, as in Fig. 62.

Transistors are very sensitive to temperature changes, and the operating temperature is just as much part of their characteristic curves as is voltage and current, so that it is necessary either to stabilize the temperature at which they operate, both internal and ambient, or to provide compensation for changes. With a pocket portable it is obviously out of the question to control the temperature, so compensation is provided. In our diagram it takes the form of a thermistor shunted across R19, which modifies the output transistor bias as the temperature changes. This precaution is necessary only in the output stage, because currents are very small elsewhere. Even in the output stage each collector would normally pass only between some 1mA and 4mA of quiescent current, but if the temperature rose sufficiently the current would rise also, and in a power circuit the transistors might be irreparably damaged.

Each output transistor is usually mounted in a small metal clip which is bolted firmly to some larger piece of metal (the output transformer or the speaker magnet, or anything that will absorb heat) to leak away any temperature rise in the transistor itself. This is called a "heat sink", and where larger powers are developed the heat sink becomes larger also. It is then fitted as a separate item, its size varying according to the amount of power the transistor has to handle, and its verticals are equipped with fins which help to ventilate the device and disperse the heat.

TRANSISTORED TUNING CIRCUITS

As an introduction to transistor receiver circuits the diagrams of Figs. 83 and 84 provide a fairly representative idea of the general principles employed in the simplest types of transistored portable receiver for a.m. reception, and they serve as a basis for an explanation of the elaborations that are found in more complicated circuits. Usually the aerial and oscillator circuits are more complicated than is shown there, and quite a number of different arrangements are found in the audio output stages. For the remainder of the circuit, between these two ends, Fig. 83 is fairly representative as it is shown.

Fig. 85 shows the type of aerial circuit that is very generally employed, together with a development of the oscillator circuit of Fig. 83. Each tuned aerial circuit has its own low impedance coupling coil to the base of the transistor TR1, which usually operates as a mixer-oscillator on the additive principle (modern valves are multiplicative, not additive, in mixing the signal and oscillator voltages). All the aerial circuit coils are wound on the ferrite rod, and the whole assembly forms an aerial system. Switch S1 connects coil L4 to its trimmer capacitors for l.w. reception, and S2 connects L5 at the same time to C2 to couple the aerial circuit to the base of TR1. Aerial tuning is performed by C1, which is one section of a pair ganged in a single unit.

The method of tuning to m.w. signals in this particular circuit is rather unusual, but it has been used occasionally in valve receivers. Instead of employing independent coils for m.w. and l.w. tuning, or connecting the two in series for l.w., as is commonly done both in valved and transistored tuning circuits, the l.w. coil L4 is independent, and for m.w. reception the m.w. coil L2 is shunted across it. For m.w., therefore, S1 connects L4 and C1 to L2. Inductances in parallel, like resistances in parallel, have a lower total value than either separately, and C1 tunes the pair over the m.w. band. Switch S2 connects L3 to C2 to provide a matched coupling impedance.

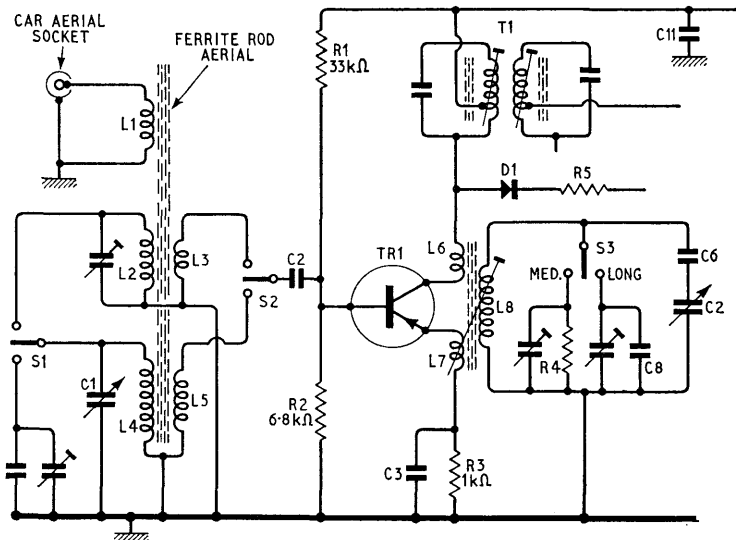

Fig. 85. Typical aerial and oscillator circuit arrangement in a transistored portable receiver. The aerial circuit coils on the left are actually wound on the ferrite rod. TR1 acts as a self-oscillating frequency changer. R1 is 33 k Ω , R2 is 6.8 k Ω and R3 is 1 k Ω

It is common practice on transistored portables to make provision for the connection of an external aerial, the principal purpose of which is to permit an aerial to be connected when the set is used in a car. The coil L1 is provided for this purpose, but it does not always work very satisfactorily because the car aerial and the coil impedances do not always match. Performance is better the lower the impedance of the car aerial.

Details of the tuning arrangements vary from model to model, but in general most receivers use the type of oscillator circuit represented in Fig. 85 by L6, L7 and L8. Reaction coupling is provided by L6 and L7 between collector and emitter of the transistor, and the resulting oscillation is tuned by L8 and C2. C6 has the effect of modifying the "law" of the tuning capacitor and keeping the aerial and oscillator tuning circuits in step. Switch S3 selects the appropriate trimmer for the waveband in use, C8 on l.w. being large enough to reduce the tuning frequency from the m.w. region to the l.w. region.

Signal and oscillator frequencies are both present in the transistor circuit, where they "beat" together to produce a range of heterodyne frequencies, from which the desired intermediate frequency is

RADIO CIRCUITS

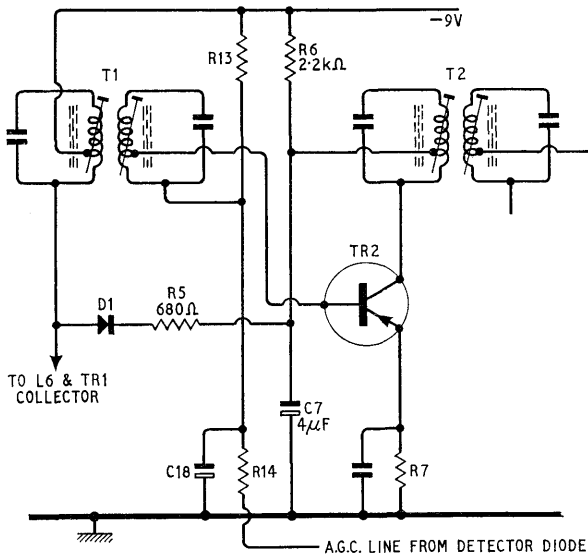

Fig. 86. Overload protection is provided by the diode D1 and R5. Hold-off bias is derived from R6, C7. The white parts of C7 and C18 indicate the positive plates of electrolytic capacitors.

extracted by the i.f. transformer T1 in the usual way. There are usually two further i.f. transformers in the i.f. amplifier, each in the collector circuit of another transistor, and the secondary winding of the third i.f. transformer T3 goes to a crystal diode detector whose load circuit comprises the volume control, which is shown in Fig. 83.

One special feature that is incorporated in the tuning circuits of many transistored portable receivers is a system of band-spreading in the region of 200m in order to make it easy for the user to tune to Luxembourg or other popular commercial transmissions. Some of the aerial circuits are made to look rather complicated when this system is introduced, but in effect all that is done usually is to switch out the variable tuning capacitor there and switch in a pre-set capacitor in its place. A three-position waveband switch is provided for l.w., m.w. and Luxembourg positions, and in the last the fixed capacitor tunes the aerial to 208m.

In the oscillator circuit, switching introduces a fixed series capacitor and a pre-set parallel capacitor which have the effect of almost swamping the variable tuning capacitor, so that swinging it

over its entire range covers only a small range of frequencies near the bottom of the m.w. band, centred on 208m.

Very little variety apart from details is found in the i.f. amplifier circuits, but there is an interesting feature that is included in many receivers. This is an overload protection device in the first i.f. stage, and it is not shown in Fig. 83. It is introduced in Fig. 85 as D1 and R5, where only one end of it is seen, but it is shown complete in Fig. 86.

It works in the following way. D1 and R5 are connected via C7 virtually across the primary winding of i.f. transformer T1, which is connected between the negative battery line and TR1 collector. Under normal reception conditions the potentials either side of D1, R5 are relatively so disposed that the R5 end is positive with respect to the D1 end, even when signals are coming in, and the diode therefore is held off, and cannot conduct. In fact it can be seen from the diagram that the positive side of D1 is connected via T1 primary to the negative battery line, while R5 is connected to the positive end of R6, so the voltage drop along R6 provides the polarizing bias. When a strong signal is received, a.g.c. current is passed back from the detector diode circuit, reducing TR2 collector

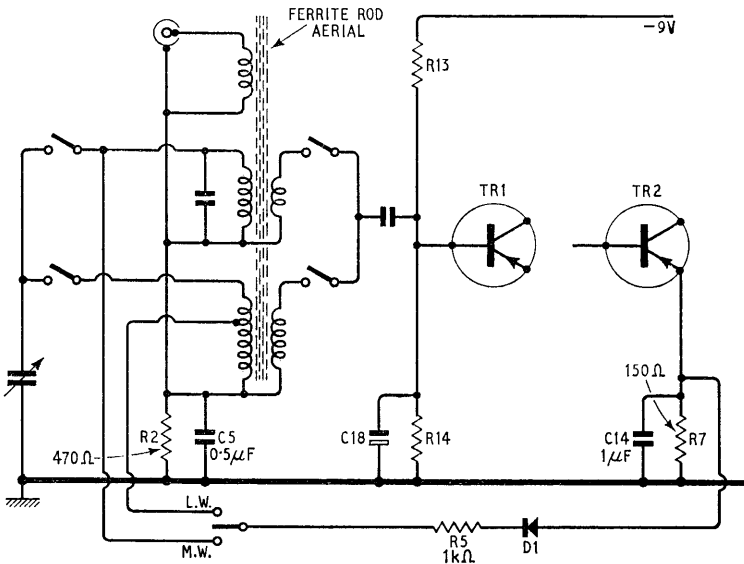

Fig. 87. In this circuit the overload damping diode D1 is biased by the emitter resistance R7 of TR2. The aerial tuning arrangements depicted here represent an alternative to those of Fig. 85

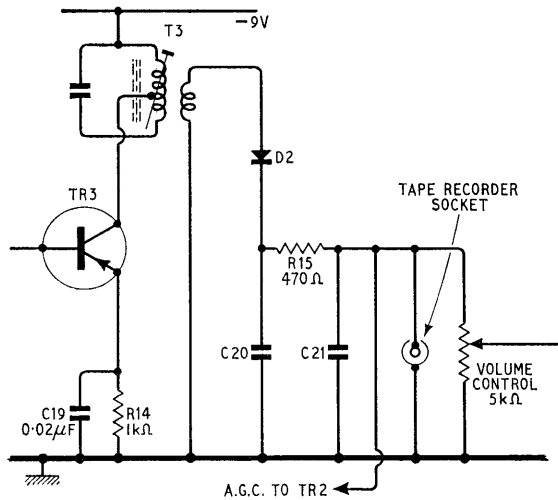

Fig. 88. Typical circuit of the i.f. output and detector stages of a transistor receiver. The tape recorder socket is found in many cases. C_{20} , C_{21} vary in value between $0.01 \mu F$ and $0.02 \mu F$

current in the normal way. This results in a reduced voltage drop along R_6 and this, combined with the larger signal voltage at TR_1 collector, allows D_1 to be driven into conduction on the positive half-cycles of the carrier.

When D_1 was held off, it formed in effect an open circuit, so that although it was shunted across T_1 , it had no effect on it. When it conducts, however, it has the effect of closing a switch, connecting R_5 across T_1 primary and damping it, thus reducing the amplitude of the signal passed on to TR_2 to a level which the transistor can handle without overloading. In operation, therefore, it emphasizes, or amplifies, the a.g.c. action at a point ahead of TR_2 .

It will be observed that it is only under active conditions, and not under d.c. conditions, that the damping can be applied. The hold-off bias to D_1 is derived from the drop along R_6 , and this can never become positive at the "top" end even if there is no current passing through it at all. What happens is that the TR_2 collector end of R_6 becomes less positive when the collector current falls, bringing D_1 nearer to conduction. D_1 only goes actually into conduction when the positive peaks of signal voltage add to the bias voltage and drive the diode into conduction in pulses. This happens at the intermediate frequency, and the larger the signal voltage the greater

the conduction on each pulse, and thus the larger the signal the greater the damping effect.

A different version of the same technique is shown in Fig. 87, where the damping is introduced into the aerial circuit. The damping diode D1 is connected via R5 between the emitter of TR2 and the m.w. or l.w. aerial tuning coils on the ferrite rod. TR1 can be assumed to be TR1 in Fig. 85, and TR2 that of Fig. 86. Under normal conditions D1 is held off by a biasing voltage derived from the voltage drop along R7, which is TR2 emitter bias resistance. The bias voltage is smaller than that in Fig. 86, partly because R7 is only 150 Ω , as against the 2.2 k Ω of R6. But the signal voltage in the aerial circuit would also be smaller than that at the collector of TR1. On the *negative* peaks of large enough signals, when the a.g.c. action from the detector circuit had reduced the emitter current of TR2, D1 would be driven into conduction, shunting R5 across the m.w. coil or the l.w. coil according to which one was in use at the time. It might appear that the shunting effect of R5 was almost nullified by R2 and R7, which are in series with R5, but of course they are by-passed by C5 and C14, and at signal frequencies those capacitors would act as almost as a short-circuit. Application of the damping here has the advantage that it prevents TR1 from being overloaded and thus avoids cross-modulation.

From this point onwards as far as the detector there is little variation, except that in later receivers the neutralizing network C9, R9, C10, R10 shown in Fig. 83 is no longer necessary, but at the detector it is a growing practice to provide a socket for the connection of a tape recorder. The essential features of the detector circuit are shown in Fig. 88, where TR3 is the second i.f. transistor and T3 is the i.f. output transformer. Its secondary winding is untuned, and it is connected directly to the detector diode whose load circuit is primarily the volume control. R15, C20, C21 form the conventional i.f. filter, although their values are different from those found in valved receivers, and the volume control value is usually 5 k Ω . If a tape recorder socket is provided it need be no more complicated than is shown in Fig. 88. Connected as it is shown there, it is intended for the making of a tape record from a radio programme, but it would be equally suitable for playback if the tape recorder had no audio output stage of its own, provided it was equipped with its own pre-amplifier. The same socket could also be used for a high impedance gramophone pickup.

CHAPTER 39

TRANSISTOR AUDIO STAGES

A great change comes over the circuits of audio amplifiers when they are designed for transistors rather than valves. Electrolytic capacitors are used to effect a.c. couplings, and it is quite common to find d.c. coupling employed. Almost invariably, even in small portable receivers, the output stage employs a Class B push-pull circuit, and often there is no output transformer. Power supply circuits, run from dry batteries of only 9V, can produce output powers as high as 1 watt, although where better quality is required two 9V batteries will be connected in series. But some small portables run very well off 6V, using four 1.5V cells.

The techniques used in audio circuits are very varied, but they conform to a few general patterns of which that shown in Fig. 89 is perhaps the simplest, and it is one that can be followed fairly easily from previously described valve circuits. The first audio transistor TR4 acts as an amplifier and a driver to the push-pull output stage TR5, TR6. These two transistors are biased so as to operate in the Class B mode, and the coupling transformer T4 is so connected as to drive the base of one transistor alternately negatively while it is driving the other one positively. The former will be conductive on one half-cycle, and will deliver power in one direction to the loudspeaker, while the latter will be driven beyond cut-off. On the next half-cycle the roles of the two transistors will be transposed, and the loudspeaker will be driven in the opposite direction.

The diagram shows that T4 has two secondaries, and it is the outer ends of these that are connected to TR5 and TR6 bases. The inner, or earthy, ends of the secondaries are connected to the bias potential divider R22, R23, R24, R25, and if valves were being used instead of transistors these two inners would probably be connected together as a centre-tapping and go to a common bias resistance, or to chassis as in Fig. 40.

The arrangement in Fig. 89 looks very different from that of Fig. 40, of course, partly because of the bias arrangement and partly

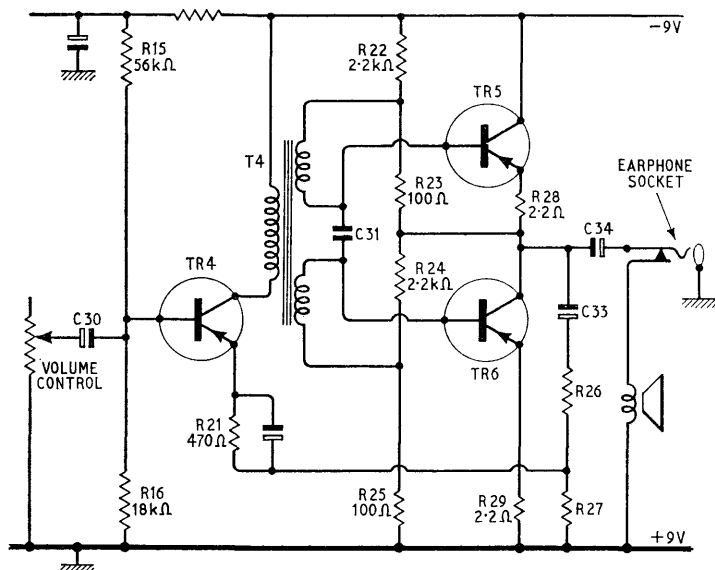

Fig. 89. A fairly simple type of transistorized Class B output circuit. Although the ends of *T4* secondary at *C31* are drawn "inside", actually they are the outer ends. The inner ends are joined together via *R23* and *R24* and they form the equivalent of a centre-tap

because it operates in the Class B mode, whereas the push-pull circuit of Fig. 40 operates in Class A. In Fig. 89, too, the transistors are connected in series with each other across the d.c. power supply, so that each virtually operates from a power supply of 4.5V. That is why the bias potential divider is arranged as it is. The power supply for TR5 and its potential divider *R22*, *R23* comes from the 9V battery, but only half of it is developed across the TR5 circuit; the circuit associated with TR6 is a replica of that of TR5, and the other half of the battery power is developed across it. The two transistors are connected in series across the d.c. circuit, and half the battery voltage is dropped across each.

Compared with most valve output circuits it would appear that the driving power to the loudspeaker must come only from TR6, but that is not true. TR5 and TR6 drive the speaker in push-pull. The method is unusual with valves, but it has been used with valve output circuits. Each transistor conducts in turn on alternate half-cycles, its impedance falling as that of the other rises, with the result that the junction of the two, at the point where *C34* is connected, oscillates at signal frequency, driving the speaker with it.

Class B operation is more readily prone to distortion than is Class A, and negative feedback is almost invariably employed. Here it is effected by feeding back some of the output signal via C33, R26, R27, which form a potential divider across the output circuit, to TR4 emitter. The provision of an earphone socket is a useful addition that is included in some receivers. When the special jack plug is inserted in the earphone socket the switch opens automatically, cutting out the internal speaker.

Having first seen the circuit of Fig. 89 it will be easier to understand how that of Fig. 90 works. As before, TR4 is a driver-amplifier with split-secondary transformer coupling, and the outers of the winding go to the transistor bases, while the inners go to the bias potential divider. Except for the omission of C31 across the transformer secondary (which in any case is only a tuning device) and the very small emitter resistors R28, R29 which again are only safety devices to protect the transistors from being over-run, the two circuits are very similar.

Although it looks different, the output circuit also is virtually the

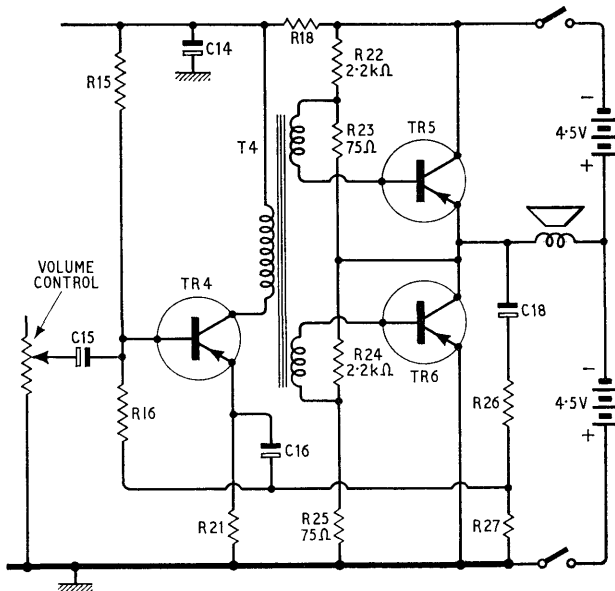

Fig. 90. Although this Class B output circuit looks very different from that of Fig. 89, actually it is very similar. By connecting the speaker directly to the centre of the battery the large electrolytic capacitor C34 in Fig. 89 is rendered unnecessary

same as that in Fig. 89. Any point on the battery is at earth, or chassis, potential so far as the signal is concerned, and here the speaker is connected to earth at the centre of the battery. Signal-wise, therefore, the speaker is connected between the junction of the two output transistors and earth, or chassis, as it was in Fig. 89. Again the 9V of the power supply is divided into two halves, so that each transistor operates from 4.5V, but in Fig. 90 no coupling capacitor C34 is necessary, because a d.c. connection can be made, and current through the transistor passes also through the speaker. As in the previous circuit, the junction of the transistor and the speaker see-saws up and down in sympathy with the signal, causing current to flow through the speaker in one direction, say to TR5, on one half-cycle, and in the opposite direction, to TR6, on the other half-cycle. As before, negative feedback is applied from the output circuit via C16 to TR4 emitter.

Both of the circuits just discussed have what is described as a transformerless output, which means that there is no output transformer to couple the loudspeaker. This feature was included also in Fig. 84, although as it was observed earlier, an output transformer is sometimes used with that type of circuit. It will be noticed that the pattern of the push-pull in Fig. 84 more nearly approaches that of valved push-pull stages than do those of Figs. 89 and 90, the opposing halves being symmetrically disposed relative to each other.

There is a type of circuit in which both the output and input transformers are dispensed with, yet no phase-splitting transistor is used, as would be necessary with a valve. Push-pull operation is accomplished by a special technique employing a "complementary pair" of output transistors, and this introduces us to the principal purpose for which n-p-n transistors are used in British receivers.

A skeleton circuit that shows the principle of the complementary output system is seen in Fig. 91. As before, TR4 is an a.f. amplifier, and again it operates as a driver transistor to the push-pull output pair TR5, TR6. Its output, however, is applied directly to the bases of both TR5 and TR6, so that the same signal is applied simultaneously to both. It will be noticed from what was said in Chapter 36 that TR6 is an n-p-n type, as is indicated by the outward-pointing arrowhead on the emitter, whereas TR5 is a p-n-p.

Thus a signal applied to the base of TR6 has the opposite effect to one applied to the base of TR5, and it is in this respect that these two transistors are complementary. Applying the same signal simultaneously to both bases has the same effect as applying signals of opposite phase from the opposite ends of a transformer winding to a pair of p-n-p transistors like those in Figs. 89 and 90.

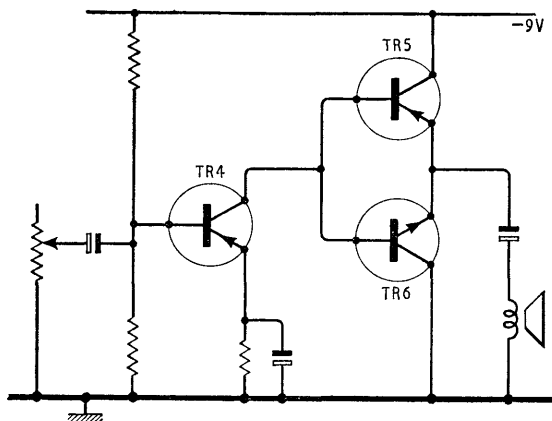

Fig. 91. Skeleton circuit showing the principle of an audio amplifier employing a complementary pair of output transistors. TR5 is a p-n-p and TR6 is an n-p-n

It will be seen that these two transistors are connected symmetrically in opposition, one collector going to the negative battery rail and the other to the positive, while their emitters are joined together. Complementary transistors are supplied in matched pairs and they are used in the Class B mode.

When a signal arrives it drives one transistor into conduction on one half-cycle and the other beyond cut-off; on the other half-cycle it drives the first transistor beyond cut-off and the second one into conduction, just as it did the pair of p-n-p types described earlier.

Complementary circuits vary considerably, and they can become very complicated in commercially produced receivers, because usually the stage or stages that precede the output pair are more closely associated with it than are the simpler types that were shown previously, and it is not uncommon to find as many as four or five transistors in the a.f. amplifier, and more than one of them may be of the n-p-n type.

The circuit of Fig. 91 was of skeleton form, but a commercially used circuit employing a complementary pair that is not unduly complicated is shown in Fig. 92, where the simple pattern of Fig. 91 can be quite easily followed. From the volume control the signal is fed to TR4 which as before operates as an a.f. amplifier. Its output is applied to another p-n-p transistor TR5 which operates as a driver to the complementary push-pull pair of output transistors TR6 and TR7. This diagram is complicated by the introduction of the

potential divider R26, R30, R24, but for our purposes this can be ignored, because signalwise TR5 collector goes directly to TR6 and TR7 bases, as did TR4 in Fig. 91. There is also a feedback circuit which further complicates Fig. 92.

Stability of the bias circuit is important, and in this practical circuit stable bias is maintained by R26, R30 and R24 which form a potential divider whose current is governed by the collector of TR5. It is adjusted to a specified value during production by means of R30, and in order to compensate for changes in ambient temperature, to which transistors are very sensitive, a thermistor Th is shunted across R24. There is negative feedback from the output circuit via R27 to TR5, and there is additional feedback via the bias potential divider from the speaker speech coil.

Compensation for temperature change is often incorporated in output transistor circuits, both to prevent thermal "runaway" which can destroy a transistor, and to prevent distortion. Compensation is sometimes provided also for falling battery voltage, which causes serious distortion to occur as the battery wears. A time comes in all battery receivers, valve or transistor, when, as the battery runs down

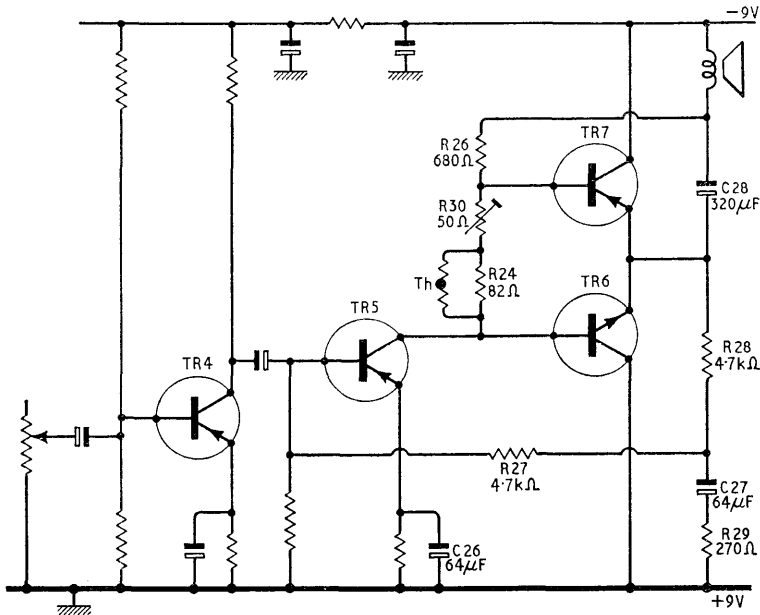

Fig. 92. An example of one of the simpler forms of Class B output circuits using a complementary pair of transistors. No phase-reversing device is needed

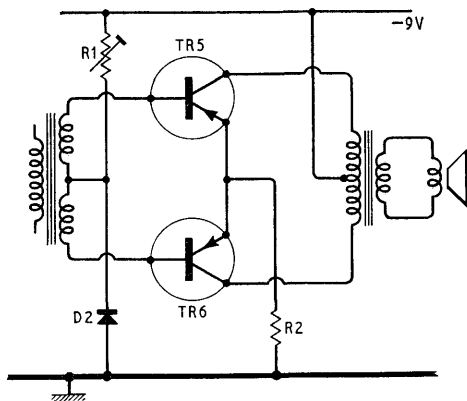

Fig. 93. A simple potential divider comprising R1 and D2 will compensate for temperature changes and falling battery voltage

and its voltage falls, a point is reached at which the set would still operate except that its oscillator (all sets today are superhets) fails to oscillate, with the result that no signals can be received.

When Class B is used in the output stage this point is not usually reached before severe distortion sets in. This is described as "cross-over distortion" because it occurs at the point where one Class B output transistor takes over on the opposite half-cycle from the other. For the cross-over to be accomplished smoothly it is necessary to adjust the bias accurately, and the adjustment must be related to the collector current which, of course, falls as the battery voltage falls.

There are several types of compensating circuit that can automatically accommodate changes in base bias, and usually they apply appropriate correction whether the change is due to temperature variation or falling battery voltage. Usually they are based on the principle that semiconductors are affected by temperature, and on the initial non-linearity of their characteristic curve. Their purpose in the case of falling battery voltage is to raise the base bias (in the "forward" direction) which otherwise falls with falling battery voltage, and restore it nearly to its original value. Collector current, which is also falling, is then increased to a value which is near that with a new battery.

One quite simple method is shown in Fig. 93, whose mode of operation, however, is not immediately obvious. Under normal circumstances the resistance of the diode D2, which is itself "forward" biased is very low, but as it forms a potential divider with R1

from which the bases of TR5 and TR6 are tapped off, it does apply a small degree of negative (forward) bias to the transistors whose emitters are returned via R2 (having a value of only 4 or 5 Ω) to chassis. When the battery voltage falls, current through the potential divider must fall, and because the characteristic of D2 is non-linear, its resistance increases. The value of R1 remains constant, so the proportion of the voltage drop across D2 rises, making the bases more negative. This is equivalent to the emitter becoming more positive, and thus it increases their forward bias. Initial setting of the correct bias current is effected by adjustment of the pre-set resistor R1.

It was mentioned earlier that some of the transformerless circuits with complementary output stages become rather complicated, and one is shown in Fig. 94 which provides an example of another use of a diode to compensate for temperature and battery voltage variations. The diode is again D2, and as before it is included in the bias potential divider for the output bases, but this time it is actually in the collector circuit of the driver transistor TR5 which itself forms part of the potential divider. The action of the diode is fairly straightforward, its internal resistance changing with variation of temperature or of the current passing through it.

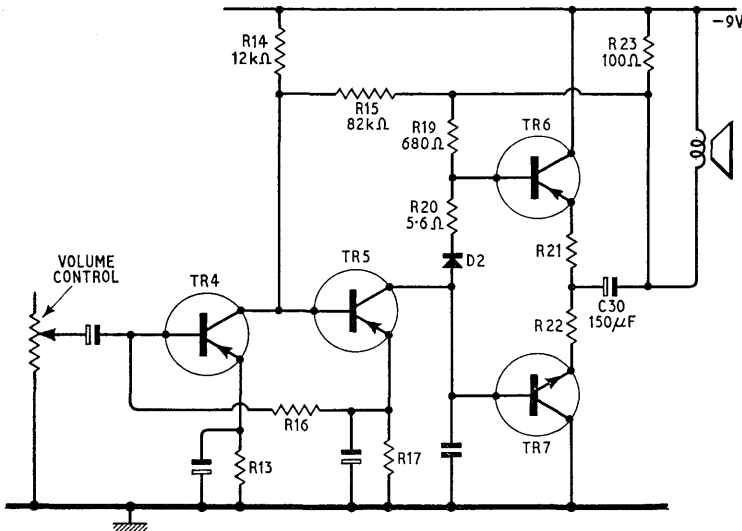

Fig. 94. How complicated the combination of a.c. and d.c. feedback couplings can become in a fully compensated complementary output circuit is demonstrated in this diagram

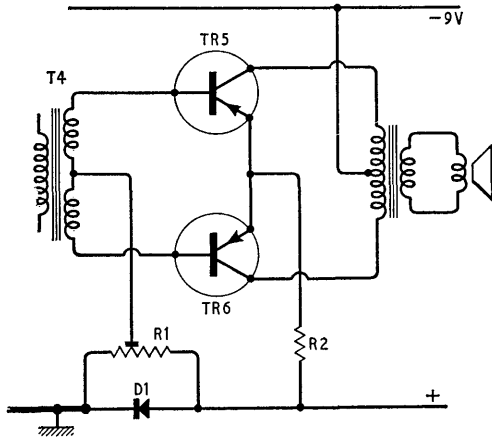

Fig. 95. A simple method of compensating for falling battery voltage in a Class B output stage

The complication comes from the interconnection of the d.c. couplings between the various transistor electrodes. R14 is the collector load resistance for TR4, but it is shunted by the potential divider R23, R15, from whose junction the bias network is taken. This provides d.c. feed-back between TR5 and TR4 and between them and the bias network. There is further feed-back coupling via R16 between TR5 emitter and TR4 base, and TR4 depends upon TR5 for its base bias. Signal frequency feed-back is also applied from the speech coil circuit from C30, R23. From the signal viewpoint, of course, the connection of the speech coil to the 9V negative battery line is equivalent to connecting it to the chassis line, because both sides of the battery are earthy.

Quite a simple circuit incorporating a bias compensating diode is shown in Fig. 95, which will be recognized as being of the same type as that in Fig. 84 in Chapter 36. There a thermistor was employed to compensate for temperature changes, but here the diode method is used, and it is included in the positive side of the power supply to compensate also for falling battery voltage. Its resistance varies, as before, with temperature and current variations, and the resistance shunted across it provides a means of initial adjustment. Once the slider has been set for a given condition of temperature and current the bias should remain correct when conditions change.

CHAPTER 40

TRANSISTORED A.M./F.M. RECEIVERS

In the same way as it is normal practice to employ an r.f. amplifier at signal frequency in a valved f.m. receiver, so is it the usual practice in transistored f.m. receivers to employ a transistored r.f. amplifying stage. And in the same way as a.m./f.m. receivers were found in Chapter 35 to be able to employ some of their valves for both a.m. and f.m. operation, so are transistored a.m./f.m. receivers able to use some of their transistors for the dual operation. In fact, apart from the special biasing arrangements, the low power supply voltages needed and the absence of heater circuits, there is considerable similarity between valved and transistored circuit diagrams. Greater disparities are found in the characteristic parameters, of course, the much lower impedances of the transistors alone rendering valve circuits quite unworkable with transistors, but these factors are not evident in a circuit diagram.

As with valved receivers, there is one transistor stage that operates on a.m. as a frequency changer and on f.m. as an i.f. amplifier, and this is preceded by a ferrite rod aerial system that acts as the a.m. aerial in exactly the same way as any of those that are used in a.m.-only receivers, of which Fig. 85 is a representative example. This same transistor stage is also preceded by an f.m. tuner, which like that in valved receivers comprises a small compact unit encased in a screening can. This unit contains all the f.m. signal tuning circuits with two transistors: the r.f. amplifier and the mixer/oscillator.

This arrangement is the same as it was in the valved f.m. receiver, with the exception that the two valves were the two halves of a double triode valve. Like the valve mixer/oscillator, the transistor type operates on the additive principle, which simply means that the two signal voltages, that of the incoming carrier and that of the local oscillation, add together (vectorially) to produce the i.f. carrier, instead of modulating the gain of the valve (or transistor).

The diagram of a representative f.m. tuner unit is shown in Fig. 96, and the first thing that will be noticed is that the r.f. amplifier

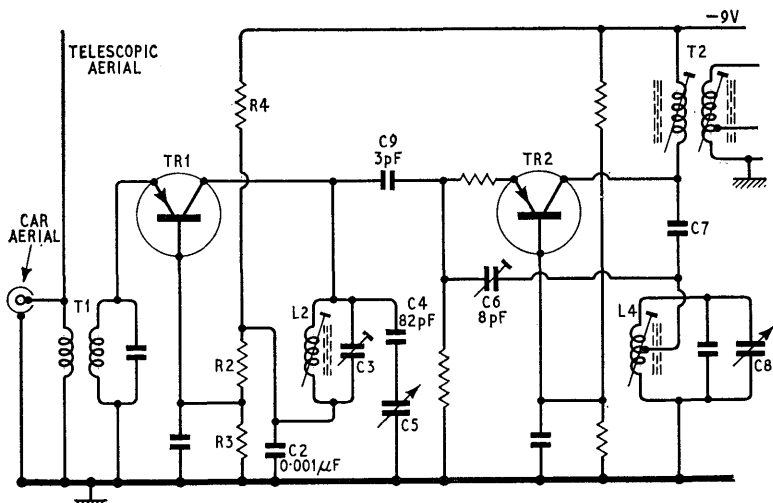

Fig. 96. Representative circuit of the f.m. tuner unit in a transistored a.m./f.m. receiver. Both transistors operate in the earthed base mode. T2 is the first i.f. transformer

TR1 is connected in the common base mode; that is to say, its base is earthy. At normal frequencies this is not a very efficient mode of operation, but it is much more suitable for high frequency work and of course this transistor must amplify at about 100Mc/s. It will be observed that in comparison with valves, the common base mode of connection is similar to that of an earthed-grid valve, which is the mode of operation used for valve circuits in the same position, as was explained in connection with Fig. 70 in Chapter 32.

The same degree of screening that is provided by the earthed grid between the anode and cathode of a valve cannot be obtained with a transistor, of course, and great care is necessary in designing an f.m. tuner to prevent the oscillator voltage from reaching the aerial and being radiated. The problem is not as severe with transistors as it is with valves, however, because, owing to their comparatively low impedance, the voltages developed are very small and stray leakage couplings are less likely to occur. The presence of the r.f. amplifier and efficient screening combined with the low level of power, is sufficient to avoid radiation of the oscillator voltage at a high enough level to cause interference with other receivers.

Various means are employed to couple the aerial to the r.f. transistor, but in Fig. 96 a simple transformer is shown. This

permits the use of a balanced primary if required for a conventional horizontal dipole aerial, but the most popular arrangements dispense with that and include a telescopic rod aerial, as shown. Usually it will be hinged as well as telescopic so that it can be adjusted to the angle at which the best reception is obtained. In most portables of all kinds except very inexpensive ones a socket is provided for a car radio aerial, and on f.m. any kind of external aerial could be connected to it. The aerial circuit is matched to the input impedance of the transistors by suitably proportioning the number of turns on the primary and secondary windings on T1.

TR1 collector circuit is tuned by L2 and C5, with tracking correction by C4 and trimming by C3, which is usually pre-set at the factory and is not intended for adjustment during re-alignment. Re-alignment adjustments are usually made on the ferrite cores of the tuning coils. C5 is shown connected directly to the earth line, although normally it is connected directly to the bottom of L2 which, however, would usually go straight to earth. In this particular circuit battery power to TR1 collector is fed from R4 through L2, so the coil cannot be connected to earth, which is the positive battery line.

C2 couples C5 to L2, and it will be obvious that C5 is intended to go straight to L2. The reason for taking it to the earth line instead is that the physical construction of the gang assembly demands it. The metal frame is large and therefore must be earthed, and in any case there are two sections in the gang and the frame is common to both. So normally it must be earthed.

A very small capacitor C9 couples TR1 collector to the oscillator/mixer transistor TR2 via a stabilizing resistance. L4 is the oscillator tuning coil, and TR2 collector is tapped into it (via C7) in order to match its impedance and to avoid damping it. C6 provides positive feed-back to establish oscillation. Again alignment adjustments are made to the core of L4. Locally generated oscillations are mixed with the signal coming in at the emitter and they heterodyne each other to produce the intermediate frequency, which is almost always 10.7 Mc/s and is selected from the numerous frequencies that appear in the collector circuit by the tuning circuit of the first f.m. i.f. transformer T2.

Fig. 96 is representative of the general run of f.m. tuners, but, unlike valved f.m. tuners, every specimen appears to be different in detail when transistors are used. All follow the same general pattern, but the arrangement of the tuning circuits varies considerably. One tendency that was strong in the early days of f.m. was permeability tuning, in which the ferrite cores were mounted on a

bar that pushed them in and out of their respective coils, which stood side by side in screening cans, according to the desired tuning frequency. Another method was to include the cores in a drive cord system, so that they were moved in and out of their coils in very much the same way as a cord-driven tuning cursor is operated. The only appreciable difference between capacitative tuning and permeability tuning that can be seen in a circuit diagram, however, is that the permeability-tuned coil cores have arrows through them and the tuning capacitors have not.

Signals at the intermediate frequency of 10.7 Mc/s, as developed in the first i.f. transformer T2 in Fig. 96, are passed on to the next transistor, TR3 which operates as a self-oscillating frequency-changer on a.m., but on f.m. it is used simply as an i.f. amplifier. This is similar to the arrangement in an a.m./f.m. receiver employing valves, and in the same way the a.m. oscillator is muted for f.m. operation to prevent the generation of spurious whistles. For a.m. reception, of course, the f.m. oscillator is muted, but this is usually done by switching off the battery current to the f.m. tuner altogether.

This brings us to the next stage in an a.m./f.m. transistored receiver, of which a representative circuit is shown in Fig. 97. TR3 is the a.m. frequency-changing transistor, and it operates in the common emitter mode. Its base is connected by switching to the appropriate aerial tuning circuit or to T2, and a set of switches is shown in Fig. 97 marked f.m., m.w. and l.w. to perform this function. T2 is the same i.f. transformer as was T2 in Fig. 96, and when the f.m. switch is closed the output from the f.m. frequency-changer (TR2 in Fig. 96) is applied to TR3 base. Several switches open and close in various parts of the circuit, muting the a.m. oscillator circuit among other things, and TR3 is transformed from an a.m. frequency-changer to an f.m. i.f. amplifier.

In Fig. 97 only a simplified version of the a.m. oscillator circuit is shown, but the entire a.m. circuit from aerial to oscillator can be assumed to be similar to that shown in Fig. 85. Switch S3 shows one of several positions at which a switch might be placed to mute the a.m. oscillator on f.m. Here it short-circuits one of the feedback coupling coils.

As in valved receivers, the i.f. transformers are connected in series in the collector circuit of TR3, although there are as many different methods used for the purpose of dual i.f. operation with transistors as there are for use with valves. Series connection, as shown in Fig. 97, is the commonest general arrangement, and it is usual to short-circuit the unwanted transformer primary as is done there, where S1 short-circuits the a.m. transformer or S2

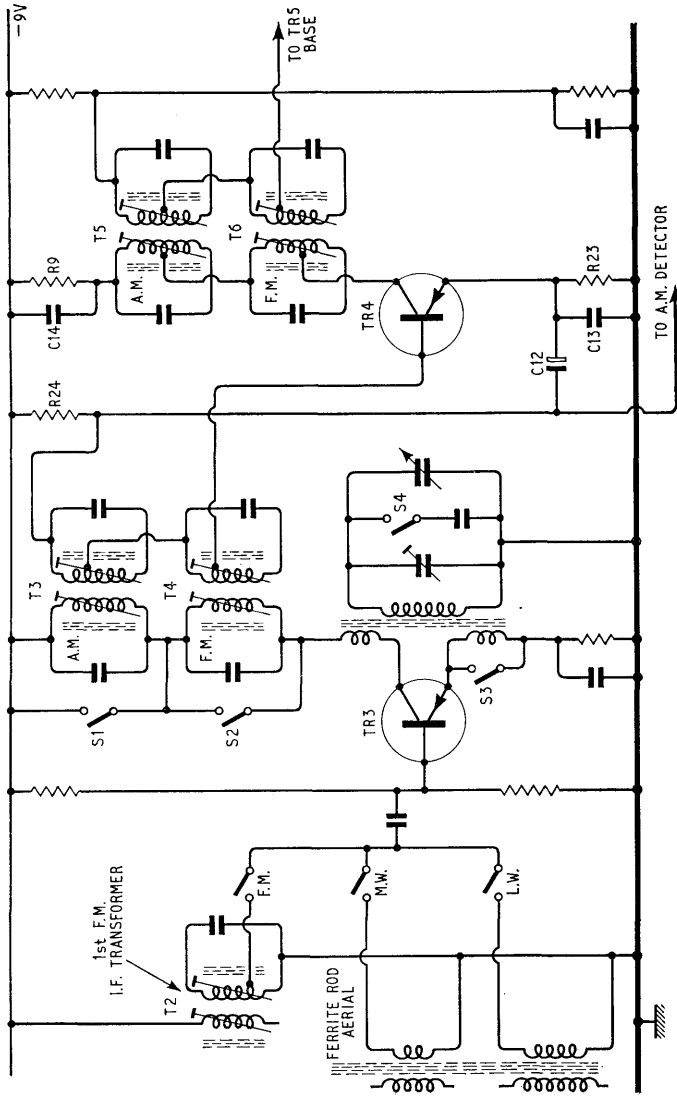

Fig. 97. First and second i.f. stages in the i.f. amplifier of an a.m./f.m. receiver employ twin transformers which are usually connected in series as shown here. T2 is the first f.m./i.f. transformer, which was seen in Fig. 96

short-circuits the f.m. one. It is quite common to transpose the two transformers, so that the a.m. one is nearer the transistor and the f.m. one is at the earthy position, on the battery line. But it is unusual to use switches in the secondary windings.

Often the secondaries or the primaries are untapped, as shown for the primaries in Fig. 97, the whole winding being in circuit between the transistor and the earthy point as it is in valved receivers, but it is more usual to tap out the lead to the base of the next transistor TR4 as shown in Fig. 97. Switching is not often used in the next pair of transformers, in the collector circuit of TR4, the automatic selection described in Chapter 35 causing only the correct transformer to respond at the appropriate frequency. There is, of course, one more i.f. amplifying stage in a.m./f.m. transistorised i.f. stages than is necessary in valved receivers just as there is in a.m.-only transistorised receivers.

It will be observed that although the a.m. detector is not in use on f.m., the base bias potential divider on TR4 is returned (from R24) at the lower (or positive) end to the a.m. detector as before, and that no switching is introduced to modify this when changing over to f.m. Switching is unnecessary, because the a.m. detector will not be receiving a signal, and the diode detector load resistance will provide a return path for the a.g.c. line to the earthy line. Nevertheless, in some circuits a switch is connected across the a.m. detector circuit to prevent any stray disturbance developing a potential there. It might appear also in the particular circuit used for Fig. 97 that the low-potential side of the secondary winding of the f.m. transformer T4 is not properly earthed, but actually it is. Its earthing path is by way of the a.m. secondary (which, to the 10.7 Mc/s signal, is like a piece of wire because the primary is short-circuited) to R24 and C12, and finally returns to the emitter of TR4.

Curiously enough, although the sequence of connection of the twin transformers in the collector circuit of TR3 is about equally divided between those with the f.m. and those with the a.m. transformer first, in TR4 collector circuit the f.m. transformer usually comes first, as shown in Fig. 97. Decoupling is shown in TR4 collector circuit by R9, C14, but this is not common. When it is employed, however, it may be associated with the type of supplementary a.g.c. device illustrated in Fig. 86 in Chapter 38, where the diode D1 and resistor R5 were connected between the a.m. frequency-changer collector and the first i.f. collector decoupling circuit. In Fig. 97 this would be between the junction of S1 and S2 and the junction of R9, C14 and the transformer winding.

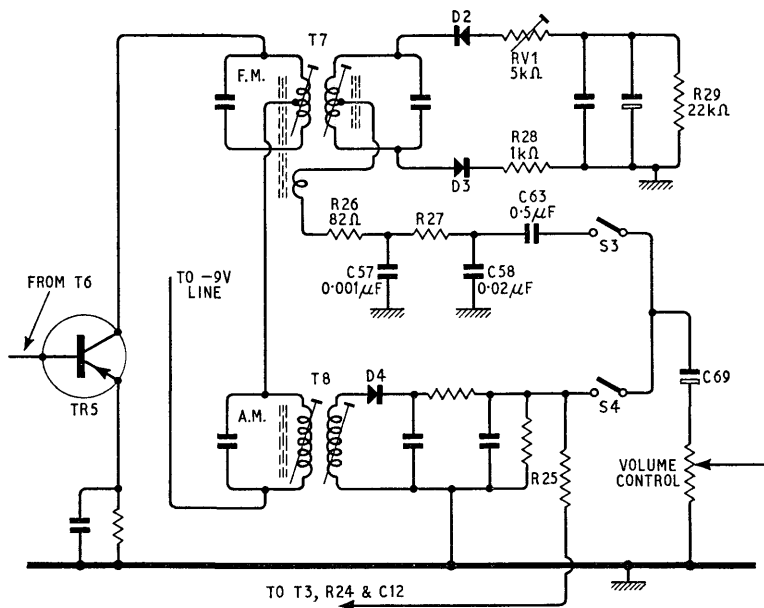

Fig. 98. Twin detector circuits are required in a.m./f.m. receivers, and it will be seen from this diagram that they are very similar to those in valved receivers. The big difference in transistor sets is in the values of the components

Although the sequence of transformer connections (that is, their order of nearness to the collector) in a transistor a.m./f.m. receiver may vary in the i.f. stages shown in Fig. 97, they are usually connected in the sequence shown in Fig. 98 in the final i.f. stage, which feeds the twin detector circuits. Here only the primary windings of the transformers are connected in series, because in a.m./f.m. receivers entirely separate detector circuits are required, and the secondary windings are part of the detector circuits. Either primary might be tapped for matching purposes, or both. T7 primary only is shown tapped in Fig. 98.

In operation the two detector circuits are quite dissimilar, but they both follow the same pattern as we have already seen in the a.m./f.m. valve detector circuits described in Chapter 34. Many variations of the basic circuit are employed both in valve and transistor circuits, but fundamentally they are similar except that the component values are very different, resistances in transistor circuits having much lower values than in valve circuits, and capacitors having much higher values. Apart from the use of crystal diodes

RADIO CIRCUITS

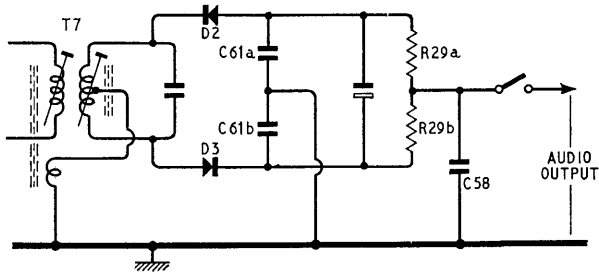

Fig. 99. In a balanced discriminator the electrical centre-line of the circuit is at chassis, or earth, potential

D2 and D3 for the ratio detector circuit in Fig. 98, therefore, the circuit is basically the same as that of Fig. 75, where the two diodes are the valves marked D1 and D2. The same could go for the Foster-Seeley diagram of Fig. 76 except that it is even less used in transistor circuits than in valve circuits. The a.m. detector stage in Fig. 98 is of course basically similar to that of Fig. 83.

Transformer T7 is the f.m. discriminator transformer, which in association with D2 and D3 rectifies the incoming i.f. carrier in accordance with variations of the carrier frequency. The secondary circuit of the transformer is centre-tapped, very *exactly centre* tapped in fact. R29 is the d.c. load resistance with an electrolytic capacitor shunted across it as a reservoir and a.f. by-pass, and a smaller capacitor which acts as an r.f. by-pass. C57 is the a.f. load capacitor, and the signal developed across it is passed via the de-emphasis network R27, C58 to the a.m./f.m. switch S3 and thus to the volume control. C63 is present in this particular circuit for d.c. isolation, but it is not always present. The same applies to C69, and for that matter to the stabilizing resistance R26. R28 and RV1 are inserted to balance the circuit for the best a.m. rejection, RV1 being adjusted to achieve the balance. These are not always used.

Variations from the basic pattern principally take the form of completely balanced circuits, in which the d.c. and a.c. networks are both equally distributed on either side of the earth line. An example is shown in Fig. 99, where the whole circuit can be seen to be equally divided and earthed at the centre. R29a and b are the two halves of R29 in Fig. 98, and C61a and b are again similarly divided. As the i.f. transformer is centre-tapped the i.f. circuit, the audio circuit and d.c. circuit are all balanced equally with respect to earth, and the balancing resistors R28 and RV1 are unnecessary.

It is the principal purpose of this book to explain the kinds of circuits that are used in radio receivers, but circuits do not convey very much information unless the reader understands the basic principles on which they work. Most of the circuits are fairly well understood by most people who are sufficiently interested to read a book of this kind, but one circuit that does not appear to be understood by many people who are quite familiar with receiver circuits generally is that of the f.m. discriminator. For their benefit, as was mentioned in Chapter 34, a simple explanation of its operation is given in the appendix at the end of the book.

Examples are given in pull-out pages of complete receiver circuit diagrams in various places in the body of this book, and among them are circuits of a.m. and a.m./f.m. receivers, both with valves and transistors. One example shows a feature that has not so far been mentioned, and that is the occasional practice, in transistored receivers only, of connecting the negative battery line to the earthy side of the circuit, and returning the collector circuits to it, instead of the emitter circuits as has been done in all our diagrams so far. Our readers understand that both the negative and positive terminals of a battery in the transistored set are at earth potential, as are the positive and negative sides of the h.t. circuit in a mains receiver using valves. So either positive or negative side can be earthy, and it does not affect the circuit in any way except that decoupling capacitors and screening, for instance, are connected to earth, or chassis, at the top of a diagram instead of the bottom.

An example of such an arrangement is inserted opposite page 167, where it will be seen that the thick earthy line is at the top of the drawing on the negative side of the battery circuit. The circuit itself is not actually affected when this is done, but some parts of it look unusual, particularly in the f.m. stages where the tuning circuits on the left are shown going up to the earthy line instead of down, giving parts of the circuit the appearance of being drawn upside down. Any point at the bottom of the drawing going to a chassis sign, of course, is actually connected to the thick chassis line at the top of the drawing. But the d.c. polarity at the top of the diagram is still negative as usual, and the bottom of the diagram is positive.

The foregoing description of a.m./f.m. transistor circuits has taken us as far as the volume control, at which point the signal comprises only the audio modulation. The rest of the receiver consists of audio amplifying and output stages, and the same kinds of circuits are used in these stages in an a.m./f.m. receiver as are used in a.m.-only receivers, which we have already covered in the earlier chapters.

CHAPTER 41

HYBRID CIRCUITS

In addition to the completely transistored types of receivers whose circuits have been described in the last five chapters, there are three other arrangements in which transistors were at one time used, and although these circuits are far less common than the all-transistor arrangements, they are encountered from time to time.

It has already been hinted that in these other arrangements the receiver is not completely transistored, that is to say, it uses transistors but it uses valves as well. In other words, there is a mixture of valves and transistors, and from this combination such receivers are described as "hybrid".

One of these arrangements formed the basis of an early departure from the all-valve complement in car radio receivers, and this is described in the next chapter. The second hybrid arrangement arises from the same considerations, but it is applied to battery-operated receivers, in which normal battery-type valves are used with conventional circuits until the output stage is reached, when an output transistor or a pair of transistors in a push-pull circuit replaces the normal output valve. The advantage of this system is that normal valves are used for the high frequency and intermediate frequency stages, where their efficiency is high and that of the transistor is low, and the transistor circuit is used where its efficiency is high. The valves that are used do not consume very much current, and although they need about 90V of high tension, a small battery can be used, or alternatively a battery of a given size will last a longer time. Such receivers are now obsolete and transistors are now more efficient than valves.

The output valve that is displaced by the transistor(s) consumes about half the total h.t. current of the receiver, and its heater requires from the l.t. cell (or battery) either twice as much current or twice the voltage compared with each of the other valves. In comparison, the transistor requires quite a small collector current, and no heater or filament power at all.

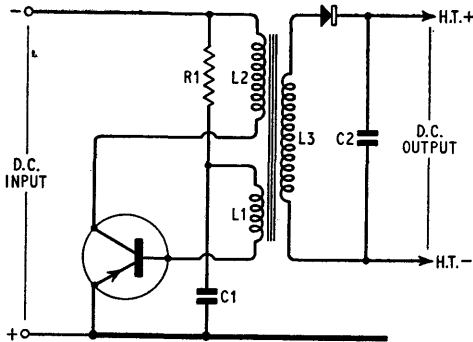

Fig. 100. The basic circuit of a transistorized d.c. amplifier, or inverter, comprising a transistor oscillator and rectifier system

As a result, although a small h.t. battery is necessary in such an arrangement, it will be called upon to supply only about half of the normal current; and because the transistor can be operated from a very low voltage, the filaments of the valves are connected in series and the transistor is run from the filament battery, where it takes so little current that the filament battery load is still lighter than it would be if it were heating the output valve filament.

The third form of hybrid arrangement is very ingenious, because its purpose and principle are really the same as that of the second arrangement just described, but the h.t. battery is disposed of, the h.t. supply being itself transistorized. Here, for the same reasons as before, in an otherwise conventional battery receiver circuit the output valve is replaced by a transistor circuit. To dispense with the h.t. battery, however, another transistor is used to generate h.t. current.

The kind of circuit that can be used for the transistorized h.t. generator, which is sometimes called an "inverter", is shown in Fig. 100. When a battery of a few volts only is applied to the d.c. input terminals, the transistor and windings L1 and L2 on the transformer form a blocking oscillator circuit. As a result of the oscillations, quite a high voltage can be induced in L3, and this is rectified by the rectifier, which can be either of the metal or crystal type. It would probably be a silicon diode.

The oscillation occurs in rather violent pulses, the periodicity of which is determined by the values of R1 and C1. D.C. output at h.t. voltages can be obtained from a 1.5V cell by this means, but higher d.c. input voltages are usually employed. By this method a hybrid

battery receiver can be operated entirely from, say, a 4.5V flash lamp battery. The three 1.4V valve filaments are connected in series and run from the 4.5V battery, and the transistor output stage is run from it also. An h.t. supply of 90V is obtained from the d.c. generator and used to supply h.t. current to the valves.

Hybrid circuits were the product of an intermediate stage between the all-valve complement and the all-transistor complement, and they are not used in the circuits of modern domestic radio receivers. They are, however, used in other quite different applications and, at the time of writing, in television receivers.

Transistor output stages—A WARNING

Care should be taken when connecting an external loud speaker, headphones or even an earphone, to any transistorized output stage employing a push-pull circuit to avoid the possibility of a short circuit on its leads. In many cases this can lead immediately to the destruction of one of the transistors.

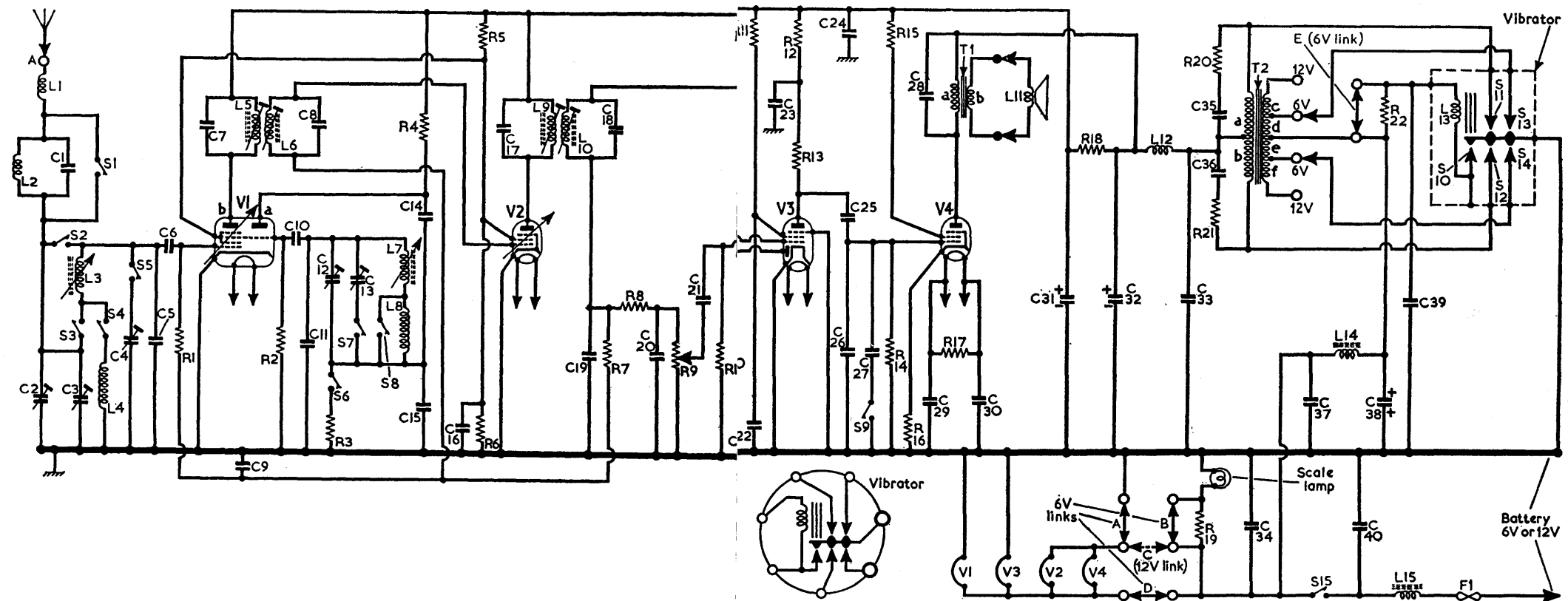

Fig. 101. Except for the omission of an r.f. stage, which is almost always provided in a commercially-produced car radio receiver, this diagram is representative of the circuit arrangement of them in the all-valve era that preceded the transistor types. Power supplies from the battery were provided by a vibratory converter, and the one shown here is of the self rectifying type. Its plug-in base connections, as seen when viewing the free ends of the pins, is inset beneath the diagram. Provision is made for operation from a 6V or a 12V battery

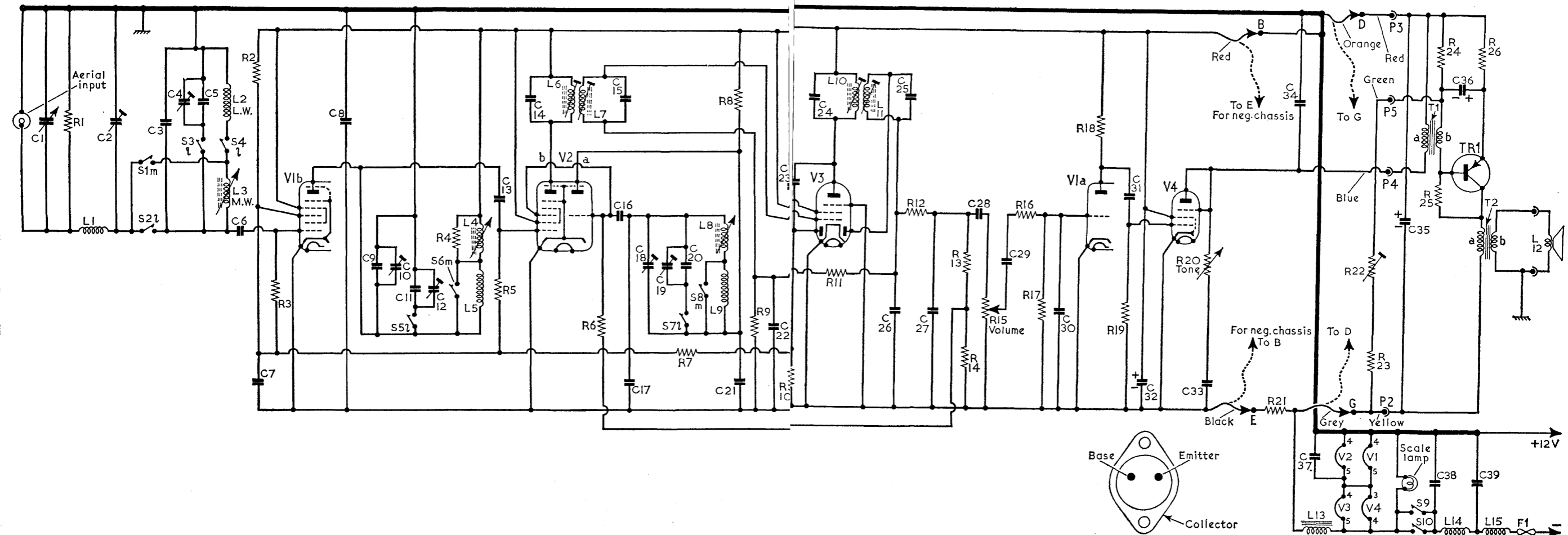

Fig. 102. Representative of the first incursion of transistors into car radio receivers is this complete circuit of a hybrid arrangement in which valves are used right up to the transformer driving the output transistor TR1. V4 is a driver to TR1, and V1a is an a.f. amplifier. V1b is an r.f. amplifier, and V3 is a double-diode r.f. pentode whose diodes rectify the signal separately to provide the audio signal and the a.g.c. potential respectively. R22 is an adjustment for the bias of TR1. As shown the receiver is suitable for a positive-earth electrical system, but it can be converted to negative-earth operation by transposing the red lead from B to E, the orange lead from D to G, and replacing them with the black and grey leads as indicated by broken line arrows in the diagram. The high tension supply is 12V

CHAPTER 42

CAR RADIO

After remaining almost static for some twenty or thirty years, the design of car radio receivers has been revolutionized recently by the introduction of the transistor. The first incursion of the transistor was in the output stage only, employing the hybrid technique described in Chapter 41, where it disposed of the power-consuming and heat-producing power output valve; but with it a new technique for running the valves in the earlier stages was introduced, in which their anode current, or "h.t.", was supplied directly from the 12V car battery. Previously all car radios used mains-type valves running at normal high tension voltages of about 350V derived from a vibratory convertor and a special type of power transformer.

Gradually, owners of ordinary transistored portable receivers found that they would work in cars, and this led to a general movement towards the use of all-transistor receivers for use in cars. The directional properties of the ferrite rod aerials used in portables created difficulties, as did also the screening effect of the car body and the pick-up of interference from electrical equipment in the car. Manufacturers began to provide portables with car aerial sockets, and users fixed make-shift aerials with clips on to the window of the car. Kits were sold with some portables, comprising a window aerial and a bracket on which to place the set when used in the car, but reception with such aerials was not very satisfactory because these aerials represented a very high impedance, and despite a special coupling winding on the ferrite rod assembly the input impedance of the receiver was very low.

This led to the development of special car/portable receivers, which were usually well-designed portables supplied with a special receptacle into which they could be inserted. The receptacle was fixed to the car permanently, and contacts in it connected the portable, when it was inserted, to the car battery and a car-size loudspeaker. When the portable was withdrawn from the case it worked like any other portable from its own self-contained battery.

Thus when used in the car its internal battery was automatically disconnected, and the set took its power from the car battery. Its power output was doubled or trebled, and it drove a large speaker, while its own speaker was muted. And a separate aerial input system was automatically connected to an independent car aerial, which it matched properly.

Finally, properly designed transistorised single-purpose car radio sets were designed for use exclusively in a car. These embodied all the technical features that were specially applicable to car reception, and output powers of up to 4W were provided, but several of the undesirable features previously associated with car receivers were dispensed with. These were mostly associated with the vibratory convertor whose output waveform was very untidy and generated a large amount of interference. This necessitated thorough filtering and smoothing, both in the leads to the set and in those coming from the battery. On top of that the vibrator emitted an audible buzz and it was the first item to suspect when the set failed to work properly. Fortunately it was a plug-in component, like a valve, and so was easy to replace.

To return to the beginning of the foregoing brief survey of car radio evolution and the all-valve versions, it may be said that car radio circuitry is not of itself a subject that presents a great deal of variety or interest, because it has little to offer that is very specialized except in its power circuits. Its radio stages must be of very high gain and the a.g.c. system must have a low (fast acting) time-constant, but otherwise it is conventional apart from the power supply circuits.

A representative circuit of car radio design prior to the introduction of transistors is shown in Fig. 101, although owing to the need for high gain and rejection of noise it was usual to employ a signal frequency amplifier in front of the frequency-changer. A common feature seen in Fig. 101 is the preset capacitor C2. Its value here is 60 pF, but it is shunted by a fixed capacitor of 100 pF, and its purpose is to balance out the capacitance of the co-axial feeder lead from the car's aerial. This capacitor is adjusted once and for all after the installation has been completed, for maximum sound output while tuned to a weak signal on the m.w. band, preferably in the high wavelength half of the tuning range of the receiver. The input circuit of the receiver is designed to have a certain value of capacitance shunted across it when the aerial is connected. The value is deliberately fixed at something greater than any aerial lead will impose, and C2 makes up the difference. Thus the designer can predict the final value of aerial plus capacitor, and design the circuit accordingly.

For the remainder, the circuit of the receiver is conventional apart from the fact that it is enclosed in a steel container, which helps to screen it from interference, and that it must obtain its power supplies from the car accumulator. This latter provision is met by the use of a vibratory convertor, and one of the synchronous type is included in the diagram in Fig. 101.

The vibratory convertor comprises essentially a reed of springy metal which has a natural tendency to vibrate at, say, 50 c/s. It is fitted with non-corrosive contacts of such material as platinum, which make and break by touching fixed contacts as the reed vibrates.

When the contacts "make" on one side of the swing, they connect one half of the primary winding of a transformer across the car battery, producing a sudden pulse of current. When the contacts "make" on the opposite side, they repeat the process, but they connect the other half of the primary winding across the battery, and this is wound so as to produce a pulse of current in the opposite direction to the first.

Thus pulses are produced alternately in opposite directions in the transformer primary at a frequency approximating to that of the mains. This is stepped up in the secondary winding to the desired voltage, then rectified to produce h.t. current as it would be in an a.c. mains receiver. The a.c. is much "rougher" than mains a.c. and requires more smoothing, but the h.t. supply voltage can be 250V or 350V if desired.

A conventional valve rectifier can be used if required, but some vibrators actually rectify the current in the secondary winding of the transformer by using another set of contacts on the same reed as the first pair, as does the example shown in Fig. 101. Because the two sets of contacts are fixed to the same reed, they can be relied upon to make and break the secondary circuit in exact synchrony with those in the primary circuit, and such vibrators are called synchronous, or self-rectifying, types. In all types of vibratory convertor the reed is made to vibrate by yet another pair of contacts, but these open and close on exactly the same principle as an electric bell, and they need no description.

Indirectly-heated valves of the conventional a.c. mains type are used in the all-valve type of car radio, their heaters being run directly from the 6V or 12V accumulator in the car. Because the waveform taken by the vibrator from the same accumulator is square-shaped, however, and arcing takes place at the contacts, a wide range of jumbled frequencies is superimposed on the smooth d.c. supply source, and drastic filtering is necessary in the heater leads to prevent it from reaching the valves and causing interference.

With the introduction of transistors it was immediately possible to dispense with the vibratory convertor, and the manner in which it was done originally is rather interesting. At first only one transistor was employed, and that was in place of the output valve, but at once it led to a significant simplification of car radio receiver design. Valves were still used in all the preceding stages, but although they looked in all respects like normal a.c. mains valves, actually they were quite special types designed to operate from a "high tension" line as low as 12V. And because their circuits involved a mixture of valves and transistors, they were described as "hybrid" circuits.

A representative circuit of an early hybrid car radio receiver is seen in Fig. 102, which employs a signal frequency or r.f. amplifying stage, indicated there as *V1b*. TR1 is the output transistor, and the valve stages between these two will be recognized from descriptions in the earlier chapters of this book. An example is seen here of the use of the chassis (in a car radio the chassis is a large mass of metal which includes the metal container) connected to the positive side of the "h.t." circuit, but it is employed for different reasons from the use of an earthy positive line in a transistored portable.

Most car electrical circuits (but not all) have their positive side earthed to the metalwork of the car, and the positive terminal of the car battery is bolted directly to the car body, so it is very desirable in the case of receivers like that in Fig. 102 that the positive side of its circuit should be connected to chassis. Otherwise the insulation must be carefully watched everywhere because the metal container is usually bolted to some part of the car body. That is why the positive side of the circuit of Fig. 102 goes to chassis (the thick black line).

It will be noticed that the arrows for the power supply, on the extreme right-hand side at the bottom of Fig. 102, are marked firmly with plus and minus signs, rather suggesting that there can be no alternative arrangement. Some cars have their negative battery terminal earthed, however, and it is usual in car receivers to make sets adaptable to positive earth or negative earth cars. The one in Fig. 102 has this facility, but in the diagram it is arranged for the more common positive earth. That is why the battery leads are so marked. For a negative earth car those leads would be transposed when they were connected to the battery, and at the same time certain simple but very important adjustments would have to be made to the power supply circuit in the receiver.

The connections concerned with the conversion from positive to negative earth are identified by the letters B, D, E, G, and the dotted

lines with arrow heads show where the leads go when the conversion is made. The lead going to B is changed over to terminal E, and vice versa; while the lead going to D is changed over to terminal G, and vice versa. If this is worked out it will be seen that the negative side of the circuit then goes to the thick chassis line. The leads to the battery of course would go to the opposite terminals from those indicated in the diagram. The four terminals B, D, E, G are usually grouped on an accessible panel on the case of the receiver and are covered by a protective plate.

The transistor circuit in a hybrid receiver is usually mounted on a separate sub-chassis which might be incorporated in the same container as the set or form part of a separate assembly in which the speaker is mounted. In Fig. 102 its connections to the main circuit are lettered P2, P3, P4, P5. These are solder-tags, and P3 must always go to the positive side of the power supply if the transistor is a p-n-p as is TR1, because that is the emitter end of the circuit. But output transistors, although they run very much cooler than valves, must be kept as cool as possible, and for that reason they are mounted on what is called a heat sink. This is no more than a fin-shaped piece of metal which conducts away the heat, but it may need to be fairly large, possibly four or even six inches square, and the transistor must be clamped tightly to it to ensure good heat conduction.

From the base connection diagram of TR1 below the circuit it can be seen that the body or case of the transistor is connected to the collector. This is done to permit the collector to be cooled efficiently by clamping the body directly to the cooling fin, but from the diagram it can be seen that the collector cannot be earthed with either polarity of the power supply. So either the fin must be insulated from the earthed container, or the transistor body must be insulated from the cooling fin.

The special valves call for little comment beyond the fact that they take their anode current directly from the positive terminal of the car battery at 12V. Decoupling components must be kept down to a minimum, but otherwise the circuit is similar to that of any other receiver with a tuned r.f. stage. The valve heaters are connected in a series-parallel circuit across the car battery, and the transistor also takes its current directly from the 12V battery. It delivers an output of 1W or 2W.

Hybrid circuits were not limited to single-transistor output. The circuit of Fig. 103 shows the a.f. and output stages of a similar type of receiver to that of Fig. 102 but with a more ambitious transistor complement, comprising a class B push-pull output stage and a

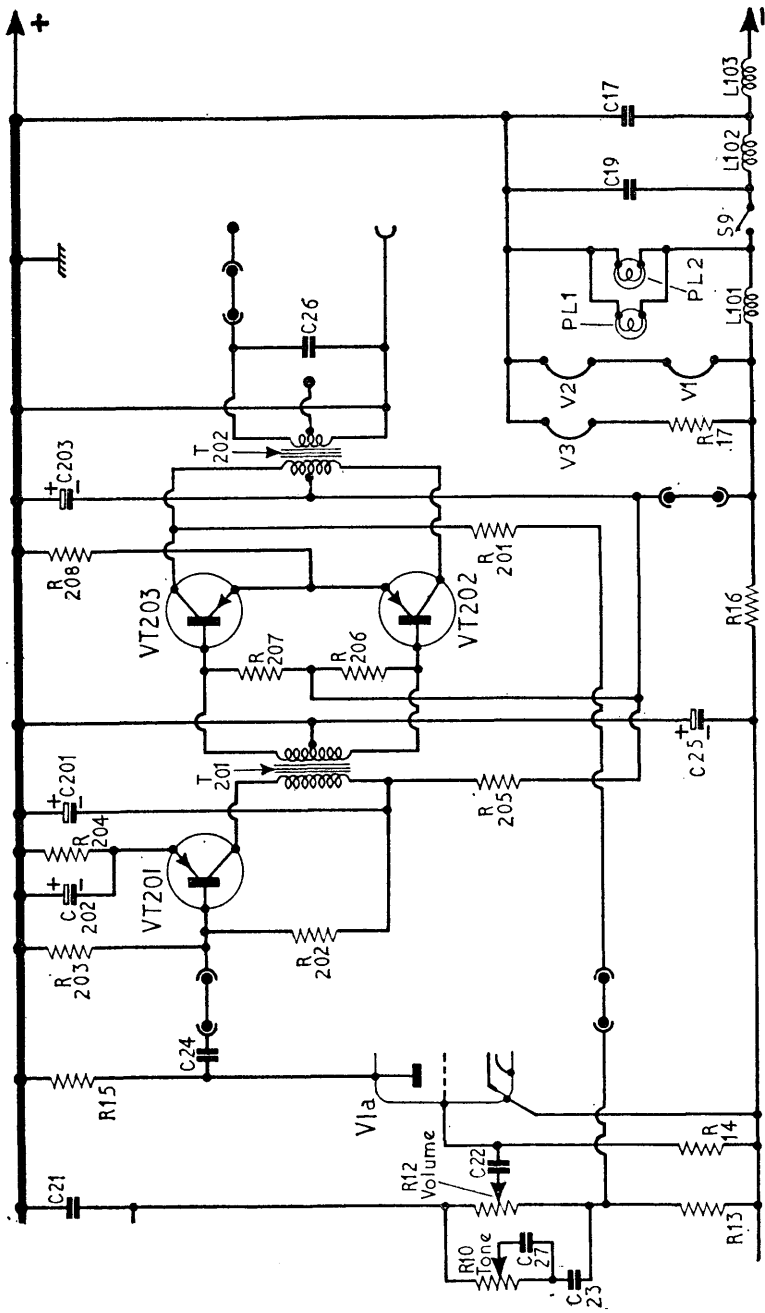

Fig. 103. Transistors in a hybrid circuit are not necessarily limited to the output stage. Here is the audio section of a hybrid car radio receiver in which a Class B output pair is driven by a transistor. The valves have 6V heaters which are connected in series/parallel, but because there are only three heaters the resistance R17 provides ballast for the odd one. The connecting links permit the transistor assembly, which is a separate unit, to be unplugged. Note the positive earth line at the top of the diagram

driver VT201, which itself is preceded by a valve a.f. amplifier V1a. Connections between the valve receiver circuit and the separate transistor unit are indicated in Fig. 103 by plug-and-socket symbols but in this particular receiver battery power connections are of a permanently soldered nature, and no provision is made for use in a car with negative earth. Up to 4W output can be obtained from the transistor output stage.

From the foregoing remarks and earlier chapters in this book it would seem that it is but a step to the completely transistored receiver. And it is, but we are then being wise after the event, because our survey covers a long period, and up to the time that hybrid receivers were current, transistors for high frequencies were very scarce and expensive. High power transistors for audio work became available some time before those for high frequencies, even as high as intermediate frequencies like 470 kc/s, and it was not until these could be produced at an economic price that it was a viable proposition to put them into car radio receivers—or of course into transistored portable sets either.

When they did become available the car receiver underwent a complete change of design. It became completely transistored, worked very efficiently from a 12V battery and caused no interference or audible buzz. Heat production was reduced drastically, and physical dimensions shrank remarkably, and a common size for the escutcheon of the front panel became 7 in. × 2 in.—about the size of a letterbox.

An example of a completely transistored car radio receiver circuit is shown in Fig. 104. This one has an r.f. stage, but it is a little unusual in omitting the second i.f. stage which is usually needed in transistored car circuits as well as in portables. An r.f. stage is more important than an i.f. stage in a car, however, to enable the best results to be obtained in the face of weak signals and many sources of interference. Less noise is generated in the receiver if a stronger signal is applied to the frequency-changer stage (TR2 in Fig. 104). Two pairs of positive/negative earth change-over links are shown, and it will be seen that in general the signal circuits are wired quite independently of the earthy line. The consumption of such a receiver as this can be in the neighbourhood of an ampere, and the output power from its single output transistor TR5 as much as 3W.

The use of portable transistored receivers in cars led, as has been observed earlier in this chapter, to special arrangements being made for them in the shape of makeshift aerials and brackets. When such arrangements involve any special provision for this in the set itself,

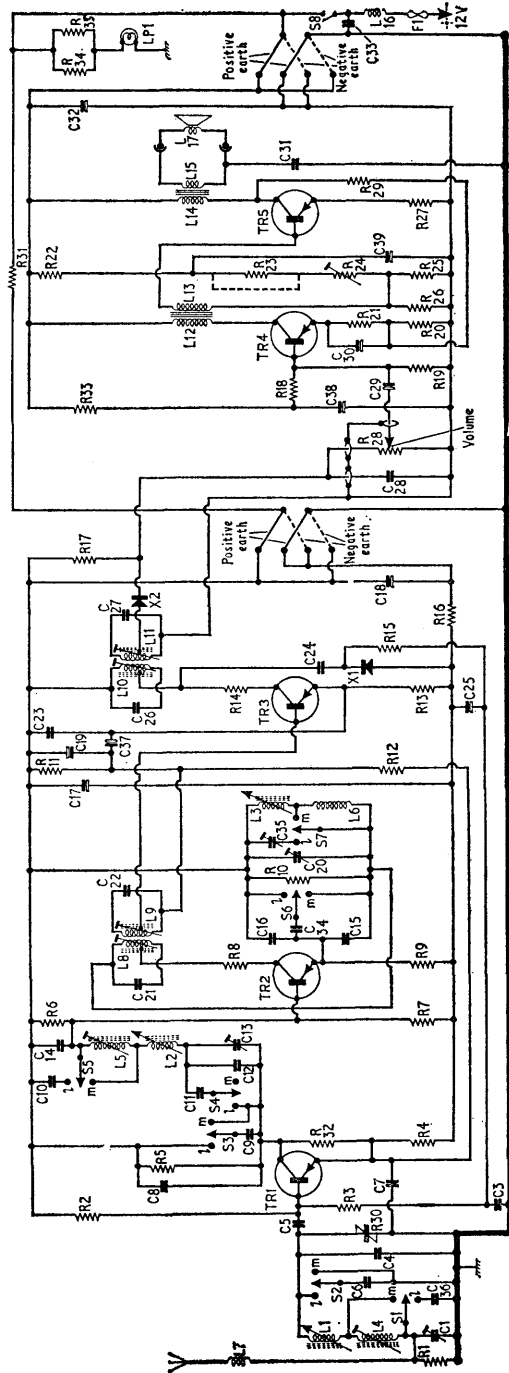

Fig. 104. Economy is effected in this receiver, which is an all-transistored commercially-produced car radio, by omitting one i.f. stage, but an r.f. stage TR1 is included, which is of greater value because it is properly tuned. No variable tuning capacitors are shown because permeability tuning is employed in the aerial and oscillator circuits, as is indicated by the arrows through the tuning coils. Polarity reversal is provided by two sets of change-over connections which, in this receiver, are soldered connections beneath the chassis deck. The output power of TR5 is 3W

the set is described as a car/portable, and the trend in this direction has led to the design of full-scale car/portable receivers with full performance specifications both for light portability and high power output car performance.

Such a receiver must be specially designed, for it incorporates features not found either in conventional portables or car receivers. A sufficiently representative example is shown in the fold-out facing page 218, where several quite new features can be detected. At the signal input, for instance, the aerial circuits are duplicated, and on opposite end of the diagram the power input circuits are duplicated.

One of the weaknesses in using a portable set in a car is that neither the ferrite rod internal aerial nor the coupling to it from an external aerial works efficiently. This is due to the low impedance of the ferrite rod aerial system and the high impedance of the aerial. Such a condition constitutes a serious mismatch, with the result that signal transfer is poor. In the diagram there are twelve switches with numbers between S4 and S23, with suffix letters C for car and P for portable after their numbers. These belong to a 2-position slide-type switch unit which changes over both the aerial circuits and the power supply and speaker circuits when the receiver is put into the car or removed from it. Switches coded "C" close to change the set over to car operation, and those marked "P" operate when the set is withdrawn.

The set is inserted into a special container when used in the car, and the container is a permanent fixture in the car. The change-over switch unit is part of this container, and it is operated automatically by means of a spring-loaded plunger which is depressed when the receiver is inserted in the container. At the same time connection is automatically made to the car aerial, which is terminated in the container, to the power supply from the car battery, whose leads are terminated in the container; and to an external loudspeaker which is fitted in the car.

As a result, when used in the car, the set is run from the car battery and delivers 1W output or more to a large loudspeaker, picking up its signal from a properly matched regular car aerial. When the set is withdrawn it becomes a normal portable, running from its own self-contained dry battery and delivering an output power of 400 mW to its internal speaker and picking up its signal from its internal ferrite rod aerial. In addition, some receivers of this type are fitted with a safety lock which may be electrically operated to prevent theft, especially when used in an open type of car.

The average consumption of one of the old all-valve receivers was about 40W of power from the car battery: about 3.5A at 12V, or

about 7A at 6V. Most British cars today use 12V, and a transistor car receiver would require about 1A, or 12W. Transistor receivers are available for 6V batteries, but their consumption would be between 1A and 2A.

In the same way that transistors offer such overwhelming advantages in portable receivers in terms of lightness, convenience and economy of power as to have ousted valves completely, so in car receivers they offer overwhelming advantages in terms of simplicity, quietness, reliability and compactness, and at the time of writing they are the only type of car receiver fitted.

APPENDIX

There are two principal features in which f.m. signal detection differs from that of a.m. One of these is in the employment of a "limiter", which is intended to prevent any change occurring in the amplitude of the carrier as it is applied to the detector, and the other is in the nature of the detector itself, which is sensitive to carrier frequency. In other respects the receiver conforms to normal a.m. receiver design, assuming that they both employ the same order of carrier frequency and bandwidth.

FREQUENCY-SENSITIVE DETECTORS

The f.m. detector, which is often called a discriminator, is fundamentally different from an a.m. detector because it is frequency sensitive, and its function is to convert fluctuations of carrier frequency to fluctuations of amplitude at audio frequency. It employs two diodes, which may be thermionic valves or crystals, and in its load circuit appear audio frequency waveforms of the same kind as appear in the load circuit of an a.m. detector.

There are several ways in which this function may be performed, and what is the best method may be a matter of opinion, but it depends mainly upon the overall efficiency of the system used. A comparatively crude method was used in the earliest days of f.m., and although it would not be used to-day it is simple in principle and easy to understand, and an understanding of it is helpful when the more elegant circuits of the modern discriminator are being explained.

We all know that as we tune a receiver into an a.m. station the response of the receiver rises as the tuning is adjusted to coincide with the fixed frequency of the transmitter. Before the tuning is correct, the signal is received on the "side" or "skirt" of the receiver's tuning response curve. Suppose the receiver's response to be like the solid line curve of Fig. A1. With the tuning adjusted to 1 Mc/s

(1,000 kc/s) and a 1 Mc/s signal coming in, the output amplitude would be at a maximum as indicated at point A. If the incoming carrier frequency were 990 kc/s, however, the output amplitude would be smaller, as indicated at B. This could be corrected by retuning the receiver to 990 kc/s, when its response curve would move to the position shown by the broken line curve.

The response at 1 Mc/s on the broken curve would be lower than it was on the solid curve, and if the tuning were moved farther away it

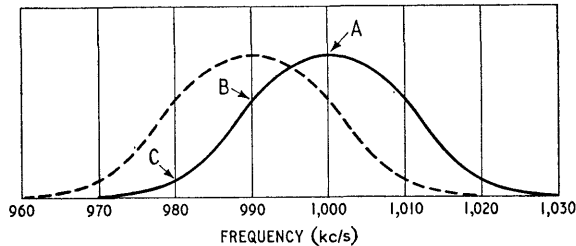

Fig. A1. If the frequency of an unmodulated carrier were changed from 1,000 kc/s (A) to 990 kc/s (B) with the set tuned to A as shown by the solid line, the output at the detector of the receiver would fall from A to B. If the set were then retuned as shown by the broken line curve the output level would rise again to A

would fall further still. If the tuning were adjusted to resonate (peak) at 980 kc/s the response at 1 Mc/s would equal that shown at C. It will be seen, therefore, that if the tuning were shifted from a peak at A to a peak at C, the output amplitude, as measured at the detector, would vary according to the response curve through A, B, C.

If the receiver tuning remained fixed and the carrier frequency from the transmitter swung over the same range of frequencies, from 1,000 kc/s to 980 kc/s, the output amplitude at the detector would vary in exactly the same way as we have shown it to vary when the tuning is swung over the same range while the carrier frequency is fixed. This is how the f.m. signal works. The modulation alters the frequency of the carrier instead of altering its amplitude, and that is why it is called frequency modulation. In Fig. A1 the nominal frequency of the carrier would be 900 kc/s, but if it were modulated it would swing, say, from 1,000 kc/s to 980 kc/s at the same rate as the frequency of the modulation, and at the detector the output amplitude would vary, again at the frequency of the modulation.

If the modulation frequency were 1,000 c/s the carrier of the transmitter would be swung back and forth 1,000 times per second, and the detector output would rise and fall 1,000 times a second,

producing a 1,000 c/s note. If the modulation swung the carrier the whole distance between A and C, that would be maximum amplitude, and anything less than maximum would swing the carrier a shorter distance either side of B.

The method just described of receiving an f.m. signal is the crudest there is, but it serves to explain the principle. The modulating frequency determines the number of times per second the carrier swings back and forth, and the amplitude of the modulation determines the extent to which the carrier is swung either side of its nominal frequency. Thus depth of modulation is measured in c/s (or kc/s) swing from nominal. This is called "deviation" since it causes the carriers to deviate from its nominal frequency.

In practice it would not be permissible to allow the deviation to swing the carrier over so wide a range as A to C in Fig. A1 because

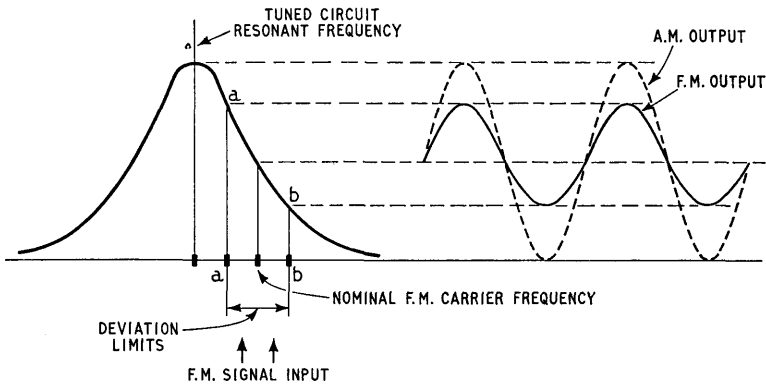

Fig. A2. If an f.m. signal were tuned in on the side of the response curve of an a.m. receiver, as indicated here, the modulation would be rectified by the a.m. detector as shown by the solid sine wave on the right. For comparison the output from a properly tuned-in a.m. signal is shown with it in broken line

the curvature of the response would cause serious distortion. The carrier deviation must be restricted to a limited portion of one side of the response curve, where the response is fairly linear, as shown in Fig. A2. Even then the response is not linear, but it is nearly so. The comparative responses from an f.m. signal and an a.m. signal on the same tuning response curve are shown in Fig. A2, where the f.m. output waveform as it would be if it were applied to a normal a.m.-type detector is shown in solid line on the right of the curve.

The a.m. output, assuming 100 per cent modulation depth and the same modulation frequency as the f.m., but on a carrier whose

frequency coincides with that of resonance of the tuned circuit, is shown in broken line behind the f.m. output. Not only is the f.m. output amplitude much smaller, but its positive half-cycles are a little larger than its negative ones, which indicates distortion.

DISCRIMINATOR CIRCUIT

A much more efficient detector circuit for f.m. was introduced about the middle Thirties and although it has since been outmoded it is probably the simplest of the special discriminators and the easiest one to understand, because it can be explained by reference to techniques familiar to radio technicians.

A typical circuit arrangement is shown in Fig. A3, but it can be rearranged to put the diode load resistors in different positions and

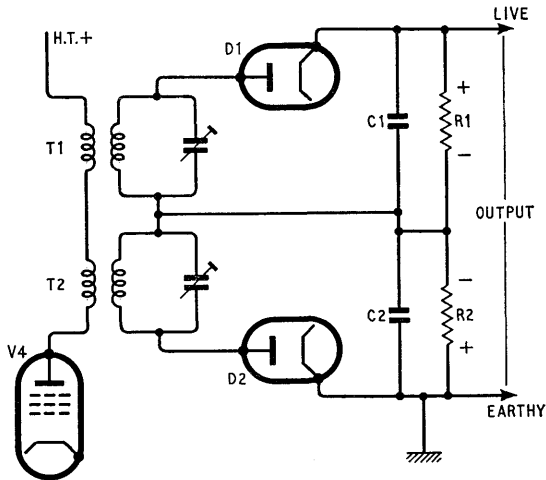

Fig. A3. A little less crude than the method shown in Fig. A2, this f.m. discriminator circuit employs two i.f. transformers, each off-tuned from the nominal f.m. carrier. In this early method the two diodes are connected in opposition

to connect a different part of the circuit to chassis. It is characteristic of f.m. detectors that they use two diodes, and it is characteristic of this particular circuit that it has two i.f. transformers, or at least two separately tuned i.f. transformer secondaries, to feed it.

This is called a double-tuned detector circuit, and it depends for its operation upon the fact that the two i.f. transformers are tuned to different frequencies. V4 is the final i.f. amplifying valve.

The nominal frequency of the carrier, that is to say the frequency at which it rests when it is not being modulated and consequently deviated, is the intermediate frequency of the receiver, which might be anything, say, between 4 Mc/s and 20 Mc/s. We could strike a round figure between these two values and assume the i.f. to be 10 Mc/s.

OFF-TUNED TRANSFORMERS

The i.f. transformers in the stages prior to V4 would therefore be tuned to 10 Mc/s, but T1 in V4 anode circuit would be off-tuned slightly, say a little on the high-frequency side, and T2 would be off-tuned on the opposite side. How far either side of the nominal i.f. they are off-tuned is important, and it is essential that they should be equally off-tune.

The result when a modulated carrier is applied is that the carrier frequency swings towards the resonant frequency of each transformer alternately, and provided that it is not permitted to reach it we have a mode of operation something like that in Fig. A2 but in duplicate, or push-pull.

As the carrier frequency swings upwards towards the resonant frequency of T1, the response of the tuned circuit increases. A rising d.c. current flows through D1 and a rising d.c. voltage is developed across R1.

When the direction of carrier swing changes, the effect is reversed, and the d.c. voltage across R1 falls. The carrier frequency will then be approaching the resonant frequency of T2, however, and the current through D2 will rise, developing a rising voltage across R2.

Some idea of the effect of this is shown graphically in Fig. A4, where the response curves of the two transformers are shown side by side. With an (i.f.) carrier frequency of 10 Mc/s, it is assumed that the peaks of the response curves of the two transformers are 200 kc/s apart, or 100 kc/s away on each side from the nominal carrier frequency.

As the carrier swings towards T1 and away from T2, the current through R1 rises and that through R2 falls, so the voltage at the "live" or high potential output terminal becomes more positive. It goes positive twice as far as the rise on R1 in effect, however, because the two diodes are connected in opposition, which looks as though their outputs might cancel out.

Instead of cancelling out, they aid each other. Although it does not look like it from the circuit, the two outputs from D1 and D2 are actually connected in series and, from a signal output point of

RADIO CIRCUITS

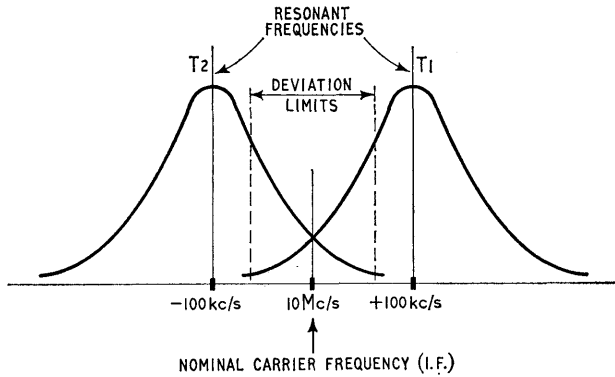

Fig. A4. Overlapping response curves for the two i.f. transformers shown in Fig. A3, tuned to frequencies 200 kc/s apart and 100 kc/s either side of the f.m. carrier, which swings from one to the other within the limits indicated

view, they are series aiding. As the top of R1 becomes more positive, the bottom of R2 becomes less positive (or more negative).

SYMMETRICAL OUTPUT

If the two circuits are properly balanced, as they must be for an undistorted output, every 1V positive rise in R1 is accompanied by a 1V positive fall in R2, and the net result is a 2V difference between the output terminals. This is clearer when it is explained that the polarity shown for the two load resistors in Fig. A3 applies only to their d.c. condition, in which they actually do cancel out.

Under d.c. conditions (which implies an unmodulated carrier) the outputs from D1 and D2 are in opposition and they cancel out exactly. As the current from D1 moves in one direction in the cycle of modulation, however, that from D2 moves in the opposite direction. Thus, as the opposition in terms of voltage increases in R1, it falls in R2, doubling the change in each of them separately, and this is what happens to the audio signal developed across them.

The circuit is entirely symmetrical, and except that the transformer frequencies are separated from the carrier in opposite directions, the whole working cycle is symmetrical, and a description of what happens to D1 and R1 on one carrier swing applies equally to D2 and R2 on the opposite carrier swing. At the output terminals the symmetry is maintained, the "live" terminal being driven positive at the same rate as the "earthy" terminal is driven negative, and vice versa.

The i.f. transformer response waveform of Fig. A4, which shows the relative frequencies of the two halves of the circuit, is redrawn in Fig. A5 to show how symmetrical positive and negative outputs can result from waveforms of Fig. A4. It will be seen that there is a crossover point between the two half-cycles which readers will remember in Class B and q.p.p. output stages, and if the circuitry is well designed this produces a linear overall response as indicated by the broken line joining the two half-cycles together.

Because it is usually desirable to have one side of an a.f. circuit at earth potential, the "earthy" output terminal in Fig. A3 is shown connected to chassis, which renders the output unsymmetrical, and like this it is suitable for connection to the pick-up sockets of a radio receiver or an amplifier. If it were desired to feed it into a push-pull circuit, the centre of the output circuit at the junction of R1 and R2 could be connected to chassis, when the "live" and "earthy" terminals would both become live, and the output would be symmetrical. It could then feed the two halves of the first stage of a push-pull amplifier.

THE PHASE DETECTOR

The next type of detector or discriminator in chronological order of development was the phase detector, which depends for its operation on the changing addition of out-of-phase voltages, rather than actual

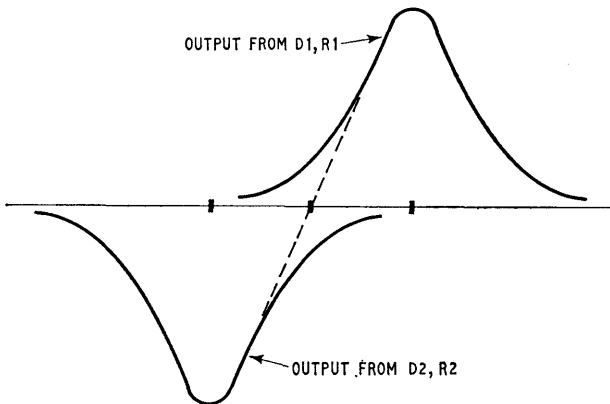

Fig. A5. Here the response curves of Fig. A4 are redrawn to the same scale with their mutual relationship indicated as applied to a discriminator. It can be seen that the output will be derived from each side alternately as the carrier frequency swings, with a cross-over point between the two sides where they overlap

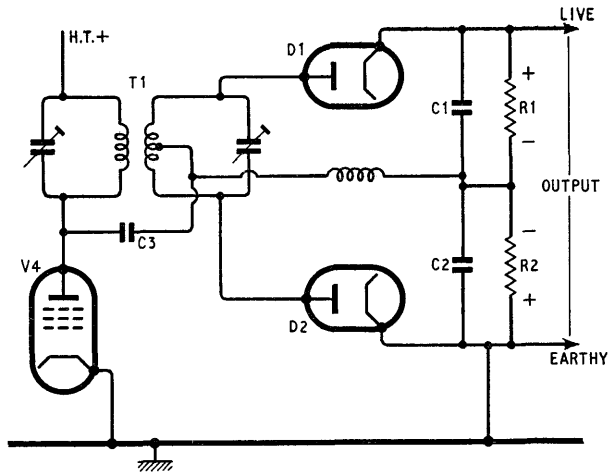

Fig. A6. Basic circuit of the phase discriminator, which is characterized by the single i.f. transformer with a phase reference coupling C3 and its diodes connected in opposition

change of voltage. It was devised by two Americans named Foster and Seeley, and is often referred to as the Foster-Seeley discriminator.

The basic circuit is shown in Fig. A6, but its action is difficult to explain without the use of vector diagrams to show the relative angular displacements of current and voltage in various parts of the circuit at different instants of time. These remain stationary while the carrier frequency remains constant, but they change when it is deviated. The similarity between this diagram and that of Fig. A3 will be seen at once, and the detector output is obtained in the same way, so it is a considerable help to have described that one first.

The primary and secondary circuits of T1 in Fig. A6 are both tuned to the intermediate frequency of the receiver, which again can be assumed to be 10 Mc/s, and while the i.f. carrier is undeviated and rests at 10 Mc/s, circuits and signal are at resonance.

The 10 Mc/s carrier voltage at V4 anode is applied via C3 to the centre-tap of T1 secondary, and is thus applied equally to the anodes of D1 and D2. The only other voltages applied to the diodes are those of the same carrier which reach the secondary by induction from the primary. These are of equal voltage but opposite phase at each diode anode.

Both diodes, therefore, conduct equally while the carrier is at the resonant frequency of the transformer, and equal and opposite

potentials appear across R1 and R2, as they did in Fig. A3. Thus the "live" and earthy output terminals are both at the same steady d.c. potential, and the a.c. output voltage is zero.

If the carrier frequency changes, the transformer is in effect off-tune, and the state of equilibrium is upset. The normal voltage and current phase relationships in the primary and secondary circuits of a tuned transformer no longer obtain. This happens when the carrier is deviated by modulation. The voltages applied to the diode anodes then depend upon the algebraic sum of V4 anode voltage at the centre-tap of the secondary and the induced voltage in the secondary winding. At resonance they are 90 degrees out of phase, but their phase relationship changes at other frequencies, in either direction, according to whether the carrier frequency is higher or lower than the frequency to which the circuit is tuned.

As the phase changes, it becomes closer at one end of the secondary to the phase at the centre, and it moves farther away at the other end. When two alternating voltages are added together like this, the nearer they are in phase, the higher is the resulting voltage; and conversely, the farther they are out of phase the lower is their combined voltage. Taken to an extreme, when they are exactly in phase their voltages add up directly, so that if they were, say 20V and 5V respectively their combined voltage would add up to 25V; or conversely, when they were exactly of *opposite* phase their voltages would add up negatively, or inversely, so that one would be deducted from the other. If they were 20V and 5V their sum would be 15V.

This is called algebraic addition, but with alternating currents the addition is a little more indirect. Voltages are then added vectorially, which means that a square root is involved in the calculation, but we need not go into that here. It is sufficient to understand that in-phase voltages add directly, and that out-of-phase voltages add less and less directly until they reach a stage at which they begin to subtract, or to neutralize each other.

It can now be appreciated that if the two ends of the secondary winding in Fig. A6 are of opposite phase, and the phase at the centre-tap is halfway between them, the phase difference between the centre and either end is the same; and the modulation voltage at each diode anode will be the same, because the phase differences, although opposite, are equal.

PHASE ANGLE

Actually, at resonance the phase difference between the two opposite ends of the secondary winding is 180 degrees, and that between

centre-tap and either end is 90 degrees, but when the carrier frequency changes this angle tilts, the tilt being proportional to the frequency change (deviation) or modulation depth. Thus the phase difference between centre-tap and one end becomes greater, and the phase difference between centre-tap and the other end becomes correspondingly smaller, and the circuit is pushed out of balance. The phase difference between the *ends* of the winding remains at 180 degrees.

Adding the voltages vectorially now gives a reduced voltage at one diode anode (where the phase difference has increased) and an increased voltage at the other (where the phase difference has diminished) and unbalanced currents flow in R1 and R2. From then on the action is the same as it was in Fig. A3.

When the carrier frequency returns to the resonant frequency of the tuned circuit, the phase differences revert to 90 degrees again, but in operation the carrier frequency then sweeps through to the other side of resonance, tilting the phase angle again, but this time in the opposite direction.

Under operating conditions in a receiver receiving a modulated signal, the phase differences between the centre and the ends of T1 secondary winding swing backwards and forwards, producing a detector output across the load resistors R1, R2 in very much the same way as the detector output in the double-tuned discriminator, and that is how the modulating voltage swings the diode anodes up and down in a phase discriminator. In practice the phase angle would not change by so much as 90 degrees and produce direct addition or neutralization of the two voltages, the maximum permissible swing being about 45 degrees. Beyond that range serious distortion is introduced.

A.F.C. DISCRIMINATOR

Many readers will have met the phase discriminator as an automatic frequency control voltage generator in certain receivers which, on being tuned near to a strong enough carrier, are automatically "pulled" into tune. Reference was made to this in Chapter 16.

This is done by using the discriminator output voltage to bias a reactance valve, which in turn alters the superhet oscillator frequency to produce the correct i.f. from a signal that is off-tune. If the off-tune frequency is high, the bias becomes more positive; or if it is low, the bias becomes more negative; or vice versa, according to the design of the circuit. It was for this purpose originally that Foster and Seeley designed this discriminator, and it was subsequently

employed as an f.m. detector. In the a.f.c. application, of course, the carrier frequency is not "wobbled" as it is in an f.m. transmission. It is off-set on one side or the other of the peak tuning point because the receiver is slightly mistuned.

From this it is evident that a d.c. output can be obtained from the system. In other words, if a carrier from a normal a.m. signal generator is fed into the circuit at 10 Mc/s, that will simulate an unmodulated f.m. carrier. If the signal generator frequency is then changed to some value within the deviation frequency of the system (plus or minus 75 kc/s) the phase differences between the centre-tap and the ends of T1 secondary will be produced just as they are when the f.m. carrier is deviated.

As a result, one end of the detector load circuit R1, R2 will become more positive than it was, and the other end will become more negative, the overall voltage (as measured from chassis) increasing or decreasing according to whether the change in signal frequency is in an upward or downward direction. The actual voltage could be measured on a high resistance d.c. voltmeter connected between the two output terminals.

THE RATIO DETECTOR

Until 1947 the phase discriminator was virtually the only type used for f.m. detection, but in that year a new type of f.m. detector, called the ratio detector, was introduced. A full technical description by S. W. Seeley and J. Avins appeared in the June, 1947, issue of *RCA Review*. Since then the ratio detector has been adopted in domestic receivers almost to the exclusion of all others.

The basic diagram of the ratio detector is seen in Fig. A7. Although it bears a family resemblance to the phase detector and the double-tuned detector its method of operation is different. It has an i.f. transformer T1 like the phase detector, but the d.c. load and the a.c. (audio) load are quite separate circuits. Usually the in-phase, or reference, signal which is injected at the centre of the transformer secondary is coupled inductively by Lc as shown in Fig. A7, but it is occasionally coupled capacitatively as it was in Fig. A6.

It employs two diodes as did its predecessors, connected to either side of the secondary winding, but they are now connected in mutually opposite directions and their audio frequency currents actually oppose each other in operation, instead of assisting each other as in the phase detector.

The d.c. load circuit consists of a single resistance R1 shunted by an electrolytic capacitor C2, revealing at once that the output in this

part of the circuit is d.c. only. C1 is merely an i.f. by-pass capacitor. The a.f. output is taken from the tapping on the secondary winding of the i.f. transformer. The d.c. currents from the two diodes are series aiding.

As in the case of the phase detector, phase variations occur between the voltages injected into the secondary winding via the coupling coil Lc and those resulting from the current induced into

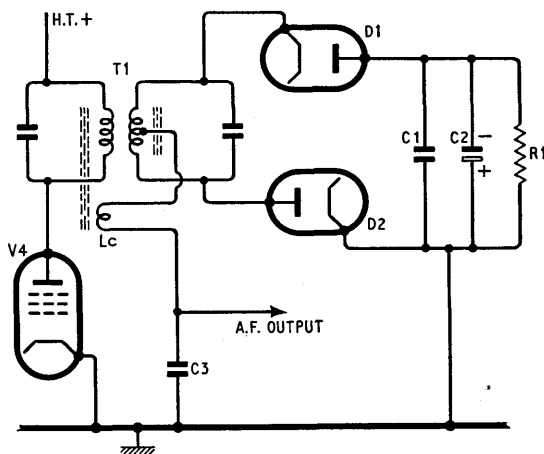
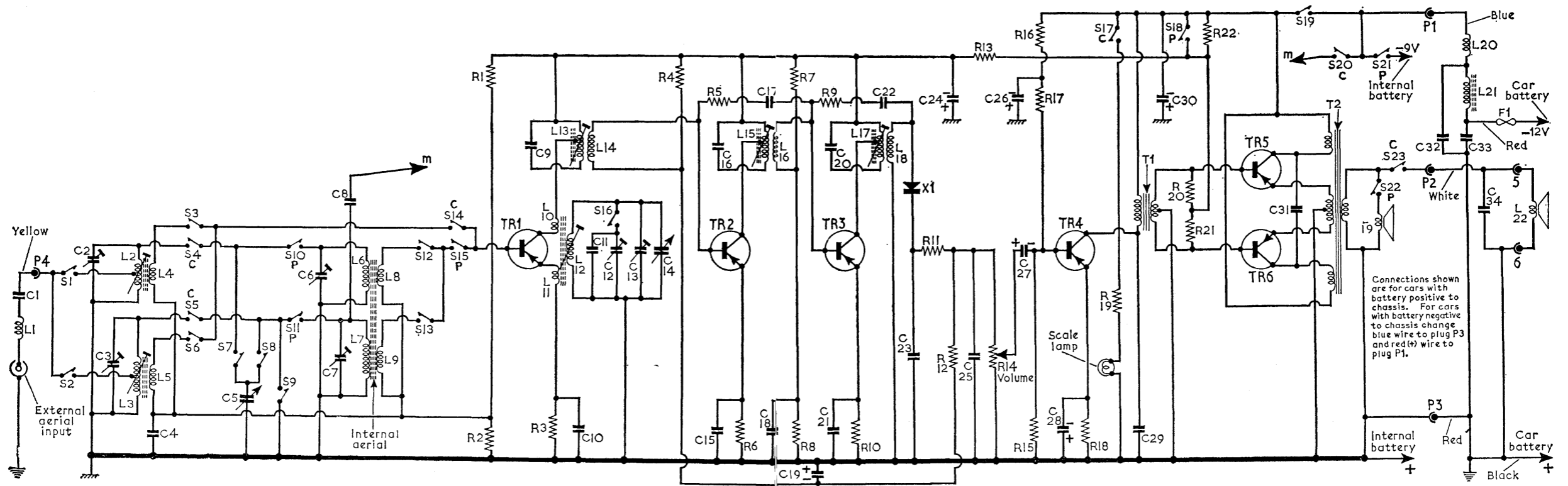

Fig. A7. Basic circuit of the ratio detector or discriminator, which is characterized particularly by the phase reference coil Lc (which can however be a capacitor like C3 in Fig. A6), and the series-aiding connection of the two diodes, with an electrolytic capacitor C2 shunted across the d.c. load R1. Its similarity to Fig. 75 is very marked

the secondary winding by its inductive coupling with the primary. The phase at one end of the secondary is always 180 degrees different from that at the other end, and when the carrier frequency is the same as the intermediate frequency they are both 90 degrees different from (or out of phase with) the voltage injected at the centre.

As the carrier frequency rises above the resonant frequency of the transformer this balance is upset, and the phase at one end of the secondary begins to approach that of the injected voltage, while that at the other end recedes to the same extent. When the carrier frequency sweeps downwards again, passing through resonance and going down below the resonant frequency, the phase at the first end recedes from that of the injected voltage, while that at the other end approaches it.



An example of the sophisticated outcome of the car radio/portable receiver technique is provided in this diagram of a properly designed car/portable radio receiver that can be withdrawn from its car receptacle and used as a normal portable receiver. When re-inserted it automatically connects itself to the car speaker L22, the car aerial, and the car battery, and operates switches that transfer TR1 input from the ferrite rod internal aerial tuning circuit to the alternative car aerial tuning circuits associated with L4 and L5, and disconnect the internal speaker L19.

This is just the same action as we saw in the phase detector. We can if we like regard the phase angles at the ends of the secondary as being fixed 180 degrees apart, while the phase of the oscillations of the voltage injected at the centre slides back and forth along the winding, approaching one end and then the other, swinging either side of a central position.

The addition of the voltages takes place just as it did for the phase detector. There are equal voltages in each half of the secondary, and they each add up with the injected voltage, positively at one end and negatively at the other (algebraically speaking) according to how nearly the phase angles agree. The resultant voltage at either end swings about a mean which is equal to the injected voltage.

The effect on D1 and D2 in Fig. A7 is that they both conduct on the same half-cycle of carrier oscillation, because they are connected opposite ways round and to opposite ends of the signal source. Their currents flow in a series-aiding direction round the load circuit R1, across which a voltage drop occurs. This voltage charges up C2, whose value is quite large, usually between 5 μ F and 10 μ F.

SEPARATE SIGNAL PATHS

To understand the working of the ratio detector it is necessary to realize that it is handling two signal frequencies: that of the carrier which is being deviated, and that of the modulation. This, of course, is common to all detectors. The oscillation that is rectified by the diodes in the manner described is the carrier frequency. The diodes conduct when the negative half-cycles of the carrier, for instance, are applied to D1 cathode. Positive half-cycles are applied at the same time to D2 anode because the diodes are connected to opposite ends of the signal source (T1 secondary).

The rectification process would take place, and the reservoir d.c. voltage would be developed in C2, in the absence of the coupling winding Lc, but the currents in the two diodes would be equal and there would be no a.f. output. Even with the addition of Lc the currents would remain equal while the carrier frequency was the same as the resonant frequency of the transformer.

In this condition the voltage across each half of the secondary winding is equal and is in series with the voltage across the coupling coil Lc, so the voltage to each diode is the same. The phase relationship between the voltage across Lc and, say, the upper end of the secondary is 90 degrees; the phase relationship between the voltage across Lc and the lower end of the secondary is 90 degrees also, but in the opposite direction. One end is 90 degrees out of phase one

way; the other end is 90 degrees out of phase the other way. The addition of the L_c voltage and either of the half-secondary voltages thus gives the same total voltage. The circuit is balanced, and there is no a.f. output.

OUT-OF-BALANCE CURRENTS

When the carrier frequency changes, and the phase of the secondary voltages changes, the balance is upset and, as was explained earlier, the phase at one end of the secondary begins to approach that in L_c , while that at the other recedes. The resultant rise of voltage, say at D1 cathode, and the fall at D2 anode, produces a condition in which less current flows through D2 than through D1. The currents in the two diodes still result from the rectification of the carrier, because they are still conducting on the same half-cycle of carrier oscillation, but as the carrier frequency deviates at audio frequency, the degree of unbalance undulates also at audio frequency. It must be appreciated that as many as a million half-cycles of carrier might be rectified during the period of one half-cycle of audio modulation.

On one half-cycle of audio frequency, for instance, the carrier half-cycles on which D1 conducts are larger than the corresponding carrier half-cycles on which D2 conducts. On the opposite half-cycle of audio frequency the carrier half-cycles are larger at D2 than their corresponding half-cycles at D1. As the carrier frequency swings up and down (with deviation), so the phase relationships in the secondary swing up and down, and the i.f. carrier voltages applied to the diodes swing up and down, at the modulation frequency.

AUDIO FREQUENCY SIGNAL

While the currents in the two diodes are equal there is no a.f. output, the rectified current virtually circulating round T1 secondary, D1, R1, D2 and back to T1 secondary on the conducting half-cycles, always in the same direction, charging up C2 in the process. When the currents are unbalanced as explained upon deviation of the carrier, the out-of-balance current flows round one half of T1 secondary, L_c , C3, along the chassis line to C1, C2, and back through D1 to T1; or on the opposite a.f. half-cycle it goes round the other half of T1 secondary, through D2, along the chassis line and through C3 and L_c to T1. From this it will be seen that the current through C3 flows in the opposite direction on each half-cycle of audio modulation, oscillating at the modulation frequency. Thus

C3 has the audio signal developed across it, and it constitutes the a.f. load impedance.

FUNCTIONAL DIAGRAMS

The process can be followed more easily from the diagrams in Fig. A8, where the current distribution is shown in (a) and (b) in opposite phases of the a.f. modulation cycle. Here the current is split up into two elements, one being represented by broken arrows and the other by solid arrows. The broken arrows represent the current that is balanced in both diodes, while the solid arrows represent the out-of-balance current resulting from modulation detection.

During detection the values of these two current elements are constantly changing, the difference (or ratio) between them varying

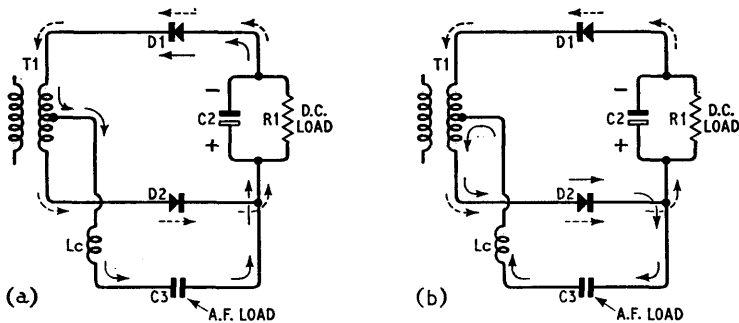

Fig. A8. Functional diagrams of the ratio detector showing how the d.c. circuits (broken arrows) and a.c. currents (solid arrows) circulate during one half-cycle at (a) and the opposite half-cycle at (b)

in proportion to the depth of modulation (volume). The balanced current (broken arrows) results from the circulation through both detectors of the residue current being passed by the less active diode, and it offsets an equal amount of the total current passing through the more active diode (broken and solid arrows).

The remainder of the total current (solid arrows), which constitutes the unbalanced current element, circulates round a circuit which includes the more active diode and the external a.f. load circuit. In (a) in Fig. A8 is shown its path on one half-cycle of the a.f. waveform, and in (b) is shown its path on the other half-cycle. The ratio between the two diode currents represented by the solid and broken arrows determines the volume of the a.f. output, hence the ratio detector. Thus on successive half-cycles of modulation

waveform the current surges back and forth through C3, and an audio frequency signal is developed across it. A volume control connected across C3 could be fed to the a.f. amplifier, as indicated by the a.f. output arrow in Fig. A7.

PRE-EMPHASIS

In practice, however, because "noise" of all kinds is predominantly high-pitched, the frequency of the modulation in an f.m. transmission is given a rising characteristic at the transmitter, and that has to be compensated in the receiver. This is a feature of the system in which operating technique plays a part in adding to its immunity from interference. The higher frequencies are emphasized at the transmitter, and when they are de-emphasized at the receiver the noise is de-emphasized with them. It is called "pre-emphasis" (at the transmitter) and "de-emphasis" (at the receiver). The amount of pre-emphasis and de-emphasis must be the same at transmitter and receiver, of course, and in any given system the pre-emphasis is one of the rated characteristics of the system, just as the frequency and the deviation are. If the de-emphasis at the receiver is different from that at the transmitter, the a.f. frequency response will be affected.

In the B.B.C. system the pre-emphasis is fixed at 50 μ sec, which is the way it is usually quoted for convenience. What this means is that the time-constant of the correcting circuit in the receiver should be 50 μ sec to restore the frequency characteristic to its proper level. A suitable correcting circuit could consist of a 50 k Ω resistor in series with a 0.01 μ F capacitor. They are identified in Fig. 78 as R16 and C26 respectively.

If the two in series are connected across C3 in Fig. A7, and the output is taken from across the capacitor, the de-emphasis of 50 μ sec will have been achieved. The values that are to be found in commercial receivers may not always appear to work out to 50 μ sec, but that may be due to compensation occurring elsewhere in the receiver, or to a desire on the part of the designer to emphasize the "top" or to boost the bass.

Throughout this Appendix the intermediate frequency, to which the i.f. amplifier is tuned and which represents what has been referred to as the "nominal" i.f. carrier frequency, has for the sake of convenience been assumed to be 10 Mc/s, because that is a round number. In fact, practically all domestic f.m. receivers use the same intermediate frequency which is, as has already been explained in the chapters on f.m., standardized at 10.7 Mc/s.

INDEX

- a.c./battery receiver 111
- a.c. load impedance 150
- a.c. power supplies 97-102
- a.c./d.c./battery receiver 111
- a.c./d.c. power supplies 103-110
- a.c./d.c. receiver 98
 - heater circuit 104
 - h.t. supply circuit 105-06
 - safety precautions 107
 - series chain of heaters 105-06
 - series/parallel heater wiring 105
- Additive principle 170
- Aerial
 - car radio 171, 197-98, 205
 - circuit 138, 170
 - coupling circuit 7
 - coupling coils 134
 - ferrite rod 11, 170, 175, 205
 - frame 11
 - input circuits 6-11
 - telescopic rod 187
 - tuning section 134
- Aerial-earth circuit 6
- a.f. amplifier, for gramophone pick-up 124-26
 - transistored 176
- a.f. amplifier stage 69-72, 168
 - function of 69
 - practical circuits 73-76
 - resistance-capacitance coupled 70
 - second 77-80
 - resistance-capacitance coupled 77
 - transformer-coupled 71-72
 - transistored 176-84
- a.f. coupling 70
- a.f. load capacitor 192
- a.f. output, Class B 89-90
 - q.p.p. 86-88
- a.f. power 69
- a.f.c. *See* Automatic frequency correction
- a.g.c. *See* Automatic gain control
- a.m./f.m. receivers 154-60
 - transistored 185-93
- Amplifier valve 3
- Amplitude modulation 1, 137
 - see also* a.m.
- Anode bend detector 130
- Anode reaction coil 29
- Anode stopper 78
- Audio frequency 2
 - see also* a.f.
- Automatic bias 66
- Automatic bias resistance 77
- Automatic frequency control 216
- Automatic frequency control discriminator 216
- Automatic frequency correction 67-68
- Automatic gain control 5, 12, 14, 56, 57-59, 127, 146, 148, 152, 153, 167
 - a.m./f.m. receiver circuits 156-58
 - amplified 62
 - car radio 198
 - circuit variations 64-66
 - delayed 60-63
 - diode load 65
 - feed circuit 19
 - filter components 65-66
 - load resistance 66
 - post-detection 62
 - quiet 62
- Automatic gain control bias 128, 149, 158
- Automatic gain control line 130
- Automatic gain control line bias potential 152
- Automatic gain control voltage 20
- Automatic volume control 55, 57
- Auto-transformer 8
- Auto-transformer coupling 72
- Background noise 62
- Balanced circuits 192
- Balanced discriminator circuit 151
- Balanced ratio detector 152
- Ballast resistance 114
- Ballast resistors 105
- Band-pass characteristics 3
- Band-pass coupling 16-19
- Band-pass effect 16
- Band-pass tuning 18
- Band-spread switch 134
- Band-spread tuning 130-35, 172
- Barretter lamp 104
- Battery, grid bias 60, 97
- Battery receivers 86, 114-15
 - power supplies 97
 - see also* a.c./battery; a.c./d.c./battery; Mains/battery receivers
- Battery voltage compensation 181-83
- Beam tetrode 79, 91
- Beat frequency 67-68
- Bias 81
 - automatic 66
- Bias battery 60, 97

- Bias compensating circuit 182
- Bias compensating diode 182, 184
- Bias requirements 102
- Bias resistance 81
 - automatic 77
- Bias resistor 83, 102, 109, 122
- Bias voltage 12, 61, 74
- Blocking capacitor 29
- Bottom capacitance coupling 8, 9
- Bridge circuit 143, 144
- By-pass capacitor 13, 65, 66, 77, 78, 82, 102, 122, 127

- Capacitance input smoothing filter 99
- Capacitative reactance 67
- Capacitative tuning 188
- Capacitor trimmer 42
- Capacitors, bottom coupling 17, 19
 - by-pass. *See* By-pass
 - coupling 55
 - decoupling 36, 44, 147
 - electrolytic. *See* Electrolytic
 - fixed 12, 14, 15, 17, 21
 - gang 39-41
 - impedance of 10
 - in series 7
 - pre-set 15
 - smoothing 99, 110
 - tone control 117-20
 - top coupling 17, 18
 - tuning 3, 14, 142, 143
 - variable 15, 39, 45
- Car/portable receivers 197, 203-05
- Car radio 197-206
 - aerial 171, 197-98, 205
 - a.g.c. system 198
 - earthing 200
 - hybrid circuit 197-203
 - power consumption 205
 - transistored circuit 203-06
 - valves 197, 199, 200
- Carrier frequency 152, 208, 211, 215, 218, 220
- Cathode bias 102
- Cathode bias resistor 141
- Cathode-ray indicator 129-30
- Choke-capacitance coupling 72
- Chokes 95, 99, 100, 108, 141
 - smoothing 92, 99, 101, 102, 109, 110
- Class A push-pull 86, 177-78
- Class B push-pull 89, 168, 176-78
- Coils, coupling 8, 10, 18, 31
 - inductance 7
 - reaction 27
 - tuning 10
- Colpitts oscillator 30
- Common base 162, 186
- Common collector 163
- Common emitter 163, 188
- Complementary output 179
- Complementary pair 179
- Complementary push-pull pair 180
- Contact potential 71, 115, 158
- Control grid 115
- Control grid circuit 158
- Control voltage 60, 63, 64, 65
- Core symbols 147
- Coupling 21-23, 33, 43-44, 46, 168
 - a.f. 70
 - capacitative 17
 - choke-capacitance 72
 - choke-fed tuned 23
 - double-tuned circuits 17
 - electron 34
 - i.f. transformer 49
 - inductive 17, 18
 - methods of 7
 - resistance-capacitance 77, 83
 - top 47
 - transformer 71-72, 81
 - tuned 22
 - tuned-anode type 22
 - tuned-secondary transformer 22
 - types of 22
- Coupling capacitor 55
- Coupling coils 8, 10, 18, 31
- Cross-over distortion 182
- Cumulative grid detector 52
- Current distribution 221
- Current indicator 127
- Current surge-limiting 101

- Damping 174-75
- Damping resistance 47-48
- d.c. h.t. power supply 98
- d.c. load circuit 217
 - see also* a.c./d.c.
- Decoupling 29, 63, 78, 141, 168, 190
- Decoupling capacitor 36, 44, 147
- Decoupling circuits 146
- Decoupling resistance 44
- De-emphasis 150, 222
- De-emphasis network 192
- Delay voltage 61, 62 66
- Delayed a.g.c. *See* Automatic gain control
- Demodulation 5, 52-56, 66
- Demodulator 3, 4-5, 59, 69, 73, 104, 108
- Demodulator circuit 70
- Demodulator load resistance 70
- Detector 52-53
- Detector circuits 55-56, 59, 138
- Detector valve 3, 4-5
- Deviation 209, 220

- Dimming lamp 127
 Diode 52, 54, 58, 73, 116
 Dipole 138-39
 Discriminator 67-68, 138, 150-53, 207, 214
 Discriminator circuit 210
 Discriminator functional diagrams 221
 Discriminator load capacitor 220
 Discriminator transformer 192
 Distortion 5, 43, 62, 79, 85, 121, 178, 181, 182
 Double-diode 5, 53, 58, 59, 61, 66
 Double-diode-output pentode 75
 Double-diode-pentode 53, 58, 104
 Double-diode-triode 53, 58, 62, 74, 104
 Double-pentode 88
 Double-triode 145, 158-59
 Double-tuned f.m. detector 210
 Driver transformer 89-90
 Driver valve 89-90
- Earthed-grid valve 186
 Earthing 99, 100, 101, 106, 108-09, 126, 141
 car radio 200
 Electrolytic capacitor 100, 106, 108, 150, 168, 176
 Electron cloud 34-35
 Electron coupling 34
- Fault tracing 6
 Feedback 67
 negative 121-23, 178
 principle of 121
 Feedback circuit 122
 Feedback voltage 121
 Feeders 139-41
 Ferrite bead 141
 Ferrite core 145, 147
 Ferrite rod aerial 11
 Filters 10, 65, 101, 108, 120
 capacitance input smoothing 99
 i.f. 10, 19
 smoothing 99, 106, 108
 First detector 31
 f.m. *See* Frequency modulation
 f.m. detector 207
 f.m. detector stage 150-53
 Folded dipole 138
 Forward bias 182-83
 Foster-Seeley discriminator 151, 214
 Frame aerials 11
 Frequency-changer 3-4, 20, 21, 31-36, 37-38, 64, 65, 104, 108, 116, 126, 159
 Frequency-changer *continued*
 additive 167
 principles of 24
 self-oscillating 188
 types of 36
 Frequency-changer circuits 31-36, 37-38
 Frequency-changer stage 24-26, 141
 Frequency changing 138
 Frequency control, automatic 216
 Frequency discriminating networks 123
 Frequency modulation 2, 137-45, 208
 transmissions 138
 see also f.m.; v.h.f./f.m. receivers;
 a.m./f.m. receivers
 Frequency response 122
 Frequency-sensitive detectors 207
 Fuses 108
- Gramophone pick-up 124-26, 156, 175
 Grid bias 5, 12, 13, 14, 67, 70, 101, 109, 112, 115
 Grid bias battery 66, 97
 Grid bias voltage, power supplies 97
 Grid capacitor 28, 29, 30
 Grid leak 28, 29, 30
 and capacitor circuit 14
 Grid resistance 83
 Grid stopper 78
 Grid stopper resistance 76
- Harmonic distortion 85, 121
 Heat sink 169, 201
 Heptode 24, 34, 36, 37, 116
 Heterodyne 4
 Hexode 24, 37
 High-fidelity amplifiers 85
 Hum 10, 104, 110
 Hum neutralizing coil 92, 93
 Hum voltages 104
 Hybrid circuits 194-95
 car radio 197-203
- i.f. amplifier 2, 156
 in f.m. receivers 146-49
 i.f. amplifier stage 43-48
 i.f. filter 10
 i.f. signal 31, 43
 i.f. transformer coupling 49
 Image frequency 25, 26
 Image interference 25-26
 Image signal 25
 Impedance 139
 Indicator lamps 105

- Inductance 147
 Instability 43, 44
 Interference 28, 117, 197
 mains-borne 101, 108
 Intermediate frequency 2, 4, 10, 25,
 26, 222
 see also i.f.
 Inverter 195
- Leaky grid 52
 Limiter 148, 153, 156, 207
 Load capacitor, discriminator 220
 Load impedance 80
 Logarithmic law 73-74
 Loudspeaker 91-96
 electro-magnetic type 92, 109
 electrostatic type 95, 96
 external connection 93, 94
 field coil 93
 field winding resistance 93
 internal muting switch 93, 94
 moving-coil/electrostatic combina-
 tions 96
 moving-coil type 91
 multi-unit arrangement 95
 permanent-magnet type 91, 109
 power requirements 69
 ribbon type 95
 two-unit arrangement 94-96
- Magic eye 129
 Magnetic amplifier 128
 Mains/battery receivers 86, 111-16
 Mains-borne interference 101, 108
 Mains receiver, power supplies 97
 Mains r.f. by-passes 101
 Mains transformer 97, 99-100
 Milliammeter 127
 Mixer 24, 25, 27, 32, 37, 38
 multiplicative 170
 self-oscillating 142
 Mixer-oscillator 170
 Modulation hum 10
- Negative feedback 121-23, 178
 Neon indicator 128-29
 Neutralization 143-45, 146
 Neutralizing circuit 143
 Neutralizing network 168
 Noise 203, 222
 n-p-n transistor 164
- Octode 34, 36
 Oscillator 24, 27-32, 37, 38, 142
 Colpitts 30
 single-coil 29
 Oscillator anode 28
 Oscillator circuits 143, 171, 172
 tuned grid 27, 28, 29, 35
 Oscillator frequency 25, 26, 32,
 67-68
 Oscillator/mixer transistor 187
 Oscillator radiation 186
 Oscillator reaction coil 28
 Oscillator tracker 42
 Oscillator tracking 39-42
 Oscillator trimmer 42
 Oscillator tuning 3
 Oscillator tuning circuit 41
 Oscillator tuning control 67
 Oscillator voltage 143, 144
 Output valve 79, 110, 159
 Over-biasing 87
 Overload protection devices 173
- Padder 29
 Padding 40
 Paralleled output valves 79
 Pentagrid 24, 34
 Pentode 20, 21, 32, 43, 53, 69, 70, 79,
 116, 141, 145, 159
 Permeability tuning 187-88
 Phase angle 216
 Phase detector 213, 218
 Phase difference 215
 Phase discriminator 216
 Phase-injection coupling capacitor
 151
 Phase relationship 215, 219, 220
 Phase-reversing valve 84
 Phase-splitting 179
 Phase-splitting valve 83
 Phase variations 218
 Plug connection 107
 p-n-p transistors 164
 Polarity 107, 168
 Potential difference 30
 Potential divider 64-66, 146, 167, 190
 Potentiometer 21, 54, 66, 73-75, 122
 Power supplies
 a.c. 97-102
 a.c./d.c. 103-110
 battery receiver 115
 mains/battery receiver 111
 Pre-amplifier 3
 Pre-emphasis 150, 222
 Pre-selector stage 3
 Press-button tuning 135-36
 Push-pull circuits 81-82
 Class A 86, 177-78
 Class B 89, 168, 176-78
 see also Quiescent push-pull
 Push-pull output 168
 Push-pull r.c. stages 83-85

- Push-pull transformer-coupled out-put stage 81
- q.p.p. *See* Quiescent push-pull
- Quiescent push-pull 86-88
- Radio-frequency amplification. *See* r.f.
- Ratio detector 150, 156, 217
- Ray control electrode 130
- Reactance valve 67-68
- Reaction coupling 171
- Rectifier 52, 53, 55, 58, 59, 98, 105, 111-12, 114
silicon 102
- Rectifier valve 97-99, 109, 110
- Rejectors 10
- Reservoir capacitance 99
- Resistance-capacitance coupling 70, 77, 83
- Resistances 114
- Resistor 110
decoupling 21
series 103
- r.f. amplifier stage 3, 20-23, 141
- Safety precautions 107
- Scale lamps 105, 109-10
- Second-channel frequency. *See* Image frequency
- Selectivity 16
- Semiconductor, derivation of term 161
- Series ballast resistance 104
- Series-fed a.g.c. circuit 12
- Series resistors 103
- Short-wave band tuning 130-31
- Shunt 10, 146
- Signal detector. *See* Demodulator
- Silicon rectifier 110
- Single-diode-pentode 53
- Single-diode-triode 60
- Skirt, of tuning response 207
- Slider. *See* Variable contact
- Smoothing 112, 114
- Smoothing capacitor 99, 110
- Smoothing choke 92, 99, 101, 102, 109, 110
- Smoothing circuit 100
- Smoothing filter 99, 106, 108
- Smoothing resistor 110
- Solid state, derivation of term 161
- Stability of bias circuit 181
- Stabilization 141
- "Staggered" tuning 48
- Stoppers 76, 78, 101
- "Stray" capacitance 15, 145
- Superheterodyne, advantages of 2
- Superheterodyne receiver 1-5
block diagram 3
- Suppressor 44
- Suppressor grid 34, 153
- Suppressor grid injection 33
- Surge current 114
- Surge-limiting resistance 108
- Switches 15
band-spread 134
make-and-break type 112-13
"on/off" 113
press-button 135-36
three-position waveband 172
wavechange 126
- Symmetrical output 212
- Tape recorder socket 175
- Temperature compensation 169, 183
- Tetrode 20, 21, 31, 43, 69, 116
- Thermal "runaway" 181
- Thermistor 105, 108, 169, 181
- Third Programme 145
- Time-constant of feed circuit 65
- Tone compensation 119, 121, 122
- Tone control 77, 117-20, 121, 123
bass cut 120
top cut 120
- Tone correction 120
- Tone correction capacitor 77
- Tracker 29, 30, 42
- Tracking 40
- Transformer coupling 71-72, 81
- Transformerless circuits 183
- Transformerless output 168-69, 179
- Transformers
a.f. coupling 168
band-pass 47-48
discriminator 192
driver 89-90
i.f. 45-46, 146, 147, 154, 156, 167, 172, 188, 211
iron-dust cored coils 45
mains 97, 99-100
matching 91
off-tuned 211
output 110
triple-tuned 47
tuned-primary, tuned-secondary 43, 142
with critical degrees of coupling 47
- Transistor circuits 161-64
aerial 170
- Transistor driver 176, 179
- Transistored a.f. stages 176-84
- Transistored a.m./f.m. receivers 185-93

- Transistored car radio circuit 203
 Transistored d.c. amplifier 195
 Transistored f.m. r.f. stage 187
 Transistored h.t. generator 195
 Transistored receivers 165-69
 a.f. amplifier stage 168
 circuits 170
 neutralizing network 168
 output stage 168
 tuning circuits 170-75
 Transistors 86
 base electrode 161
 complementary 180
 definition of 161
 destruction of 196
 material and character of 162-63
 modes of operation 162-63
 n-p-n 164
 output stage 176
 p-n-p 164
 symbol for 162
 temperature sensitivity 169
 theory of 162
 t.r.f. *See* Tuned radio frequency
 Trimmer 15, 19, 30, 42, 142, 143, 198
 Triode 27, 32, 52, 73, 77, 84, 89, 141, 142
 Triode-heptode 37
 Triode-hexode 24, 37, 38
 Triode oscillator 126
 Triode-pentode 32, 33, 35
 Triple-diode-triode 153-60
 Tuned circuits 3, 145
 Tuned-grid oscillator circuit 35
 Tuned input stage 12-15
 Tuned r.f. circuit 1
 Tuning, automatic 135
 band-spread 130-35, 172
 capacitative 188
 motor 136
 permeability 187-88
 press-button 135-36
 "staggered" 48
 Tuning capacitor 3, 14, 142
 ganged 143
 Tuning circuit 3, 142
 transistored 170-75
 Tuning control 67
 Tuning drift 136
 Tuning drive systems 143
 Tuning indicators 127
 Tuning response curve 207, 209

 Unbalance 220
 Unbalanced ratio detector 150

 Valves, amplifier 3
 car radio 197, 199, 200
 detector 3, 4-5
 directly-heated 81
 indirectly-heated 81
 rectifier 97-99, 109, 110
 variable-mu 57
 variable-mu r.f. 20
 see also Diode; Pentode, Triode, etc.
 Variable contact 73, 75
 Variable coupling 50
 Variable-mu r.f. valves 20
 Variable-mu valve 57
 Variable selectivity 49-51
 Vectorial addition 215
 Very high frequencies. *See* v.h.f.
 v.h.f. 1, 138
 radio transmissions 137
 v.h.f./f.m. receivers 137-45, 146
 Vibrators, synchronous or self-rectifying 199
 Vibratory convertor 197-98, 199, 200
 Voltage-doubler 98
 Volume control 59, 73-74, 75, 124, 125, 156, 168
 automatic 55, 57

 Wall socket connection 107
 Westector metal rectifier 53
 Whistles 28

RADIO CIRCUITS

This popular book explains in simple language and in easy stages all the varieties of circuits that are found in radio receivers of the kind that are used for sound broadcasting. It does this by taking separately each stage of the receiver, piece by piece, and explaining it without the complication of all the associated circuits round it.

In this manner every detail can be absorbed easily by the reader, who is not obliged to cope with more than he can assimilate at any one time. As he acquires familiarity with several parts, however, he is introduced to their mutual association with one another, and he is finally led to an understanding of the complete circuit of a receiver.

Since the last edition was published there has been a vast increase in the use of transistors in current radio receivers and the further development of frequency modulation. The book has been completely revised and brought up to date to include these changes and it now provides comprehensive coverage of all types of receiver including car radio and frequency modulated receivers.

228 pages, including 112 text diagrams, and 4 foldouts

Fifth
Edition